

A

MATERIALS VACUUM DEPOSITION GUIDE

-
- Technical Guide
about Thin Films Deposition A 02
 - Vapor Pressures Table A 28

Technical Guide about Thin Films Deposition

KEY OF SYMBOLS

* Influenced by composition
 ** Cr-plated rod or strip
 *** All metals alumina coated

Gr Graphite
 Q Quartz
 VC Vitreous carbon
 SS Stainless steel
 Int Intermetallic
 Ex Excellent

G Good
 F Fair
 P Poor
 S Sublimes
 D Decomposes
 RF RF sputtering is effective
 RF-R Reactive RF sputter
 is effective
 DC DC sputtering is effective
 DC-R Reactive DC sputtering
 is effective

REMARK:

Data have been collected from reliable literary sources and scientists working on vacuum deposition. Whilst great care has been taken to ensure that the information provided in this table is accurate, data should be used as a general guide and at your own risk. Do not hesitate to use a second source for very critical data or consult us.

Material	Symbol	Melting Point (°C)	S/D	Density g/cm ³ @20°C	Temp.(°C) for given Vap. Press. (mBar)			Evaporation Techniques						Index of Refraction (@µm)	Comments	
					10 ⁸	10 ⁶	10 ⁴	E-Beam		Thermal Sources			Sputter			
								Suitability	Liner	Boat	Coil	Basket				Crucible
Aluminum	Al	660	-	2.70	677	807	972	Ex	Gr, Int	Int, W, Al ₂ O ₃	W	W	W	Int	RF, DC	Alloys and wets W. Stranded W is best. Slow sputtering.
Aluminum Antimonide	AlSb	1080	-	4.3	-	-	-	-	-	-	-	-	-	-	RF	-
Aluminum Arsenide	AlAs	1600	-	3.7	-	-	~1300	-	-	-	-	-	-	-	RF	-
Aluminum Bromide	AlBr ₃	97	-	2.64	-	-	~50	-	-	Mo	-	-	Gr	-	RF	-
Aluminum Carbide	Al ₄ C ₃	~1400	-	2.36	-	-	~800	F	-	-	-	-	-	-	RF	-
Aluminum Fluoride	AlF ₃	1291	S	2.88	410	490	700	P	Gr	Mo, W, Ta	-	-	Gr	-	RF	-
Aluminum Nitride	AlN	>2200	S/D	3.26	-	-	~1750	F	-	-	-	-	-	-	RF, RF-R	Reactive evap in 10 ⁻³ N ₂ with glow discharge. Good electrical stability.
Aluminum Oxide	Al ₂ O ₃	2072	-	3.97	-	-	1550	Ex	-	W	-	W	-	-	RF-R	Sapphire excellent in E-beam. Forms smooth, hard films.
Aluminum Phosphide	AlP	2000	-	2.42	-	-	-	-	-	-	-	-	-	-	RF	-
Aluminum, 2% Copper	Al2%Cu	640	-	2.82	-	-	-	-	-	-	-	-	-	-	RF, DC	Wire feed and flash. Difficult from dual sources.
Aluminum, 2% Silicon	Al2%Si	640	-	2.69	-	-	1010	G	Gr, Int	-	-	-	Int	-	RF, DC	Wire feed and flash. Difficult from dual sources.
Aluminum-doped Zinc Oxide	AZO	-	-	-	-	-	-	-	Mo	-	-	-	-	-	RF, DC	-
Antimony	Sb	630	S	6.68	279	345	425	P	Gr, Al ₂ O ₃ , BN	Mo, Ta, Al ₂ O ₃ , ***	Mo, Ta	Mo, Ta	BN, C, Al ₂ O ₃	RF, DC	3.4@1	Toxic. Evaporates well. Film structure is rate dependent.
Antimony Oxide	Sb ₂ O ₃	656	S	5.2	-	-	~300	G	Al ₂ O ₃ , BN	Pt	-	-	BN, Al ₂ O ₃	RF-R	2.1@0.55	Toxic. Decomposes on W. Use low rate.

Material	Symbol	Melting Point (°C)	S/D	Density g/cm ³ @20°C	Temp.(°C) for given Vap. Press. (mBar)						Evaporation Techniques						Index of Refraction (@µm)	Sputter	Comments	
					10 ⁻⁸		10 ⁻⁶		10 ⁻⁴		E-Beam			Thermal Sources						
											Suitability	Liner	Boat	Coil	Basket	Crucible				
Antimony Selenide	Sb ₂ Se ₃	611	D	-	-	-	-	-	-	-	-	-	-	-	-	-	Gr	RF	3.01@0.55	Stoichiometry variable. Toxic.
Antimony Sulfide	Sb ₂ S ₃	550	-	4.64	-	-	~200	G	Al ₂ O ₃	Mo, Ta	-	-	-	-	-	-	-	-	3.2@0.55	Toxic. No decomposition.
Antimony Telluride	Sb ₂ Te ₃	629	-	6.50	-	-	600	-	-	-	-	-	-	-	-	-	Gr	RF	-	Toxic. Decomposes over 750°C.
Arsenic	As	817	S	5.73	107	150	210	P	Gr, VC, Al ₂ O ₃	Gr	-	-	-	-	-	-	-	-	-	Toxic. Sublimes rapidly at low temperature.
Arsenic Oxide	As ₂ O ₃	312	-	3.74	-	-	-	-	-	-	-	-	-	-	-	-	-	-	-	-
Arsenic Selenide	As ₂ Se ₃	~360	-	4.75	-	-	-	-	-	-	-	-	-	-	-	-	Q	RF	3.03@0.82	Toxic.
Arsenic Sulfide	As ₂ S ₃	300	-	3.43	-	-	~400	F	Mo	Mo	-	-	-	-	-	-	Q	RF	2.69@0.56	Toxic.
Arsenic Telluride	As ₂ Te ₃	362	-	-	-	-	-	-	-	-	-	-	-	-	-	-	-	-	-	Flash. Toxic.
Barium	Ba	725	-	3.51	287	354	462	F	-	W, Ta, Mo	W	W	W	W	W	Metals	RF	0.9@0.57	Toxic. Wets without alloying from refractory metals. Reacts with ceramics. Evaporates easily.	
Barium Chloride	BaCl ₂	963	-	3.92	-	-	~650	-	-	Ta, Mo	-	-	-	-	-	-	-	RF	0.74@0.58	Preheat gently to outgas.
Barium Fluoride	BaF ₂	1355	S	4.89	-	-	~700	G	-	-	-	-	-	-	-	-	-	RF	1.3@0.55	Density rate dependent.
Barium Oxide	BaO	1918	-	5.72	-	-	~1300	P	Al ₂ O ₃	Pt	-	-	-	-	-	Al ₂ O ₃	RF, RF-R	1.98@0.59	Decomposes slightly.	
Barium Sulfide	BaS	1200	-	4.25	-	-	1100	-	-	Mo	-	-	-	-	-	-	-	RF	2.16@ 0.59	-
Barium Titanate	BaTiO ₃	-	D	6.02	-	-	-	-	-	-	-	-	-	-	-	-	-	RF	2.4@0.55	Gives Ba. Co-evap. from 2 sources or sputter.
Beryllium	Be	1278	-	1.85	699	827	987	Ex	Gr, VC	W, Ta	W	W	W	W	BeO, Gr, VC	RF, DC	RF, DC	2.5@0.5	Wets W/Mo/Ta. Powder and oxides toxic. Evaporates easily.	
Beryllium Carbide	Be ₂ C	>2100	D	1.90	-	-	-	-	-	-	-	-	-	-	-	-	-	-	-	-

Material	Symbol	Melting Point (°C)	S/D	Density g/cm ³ @20°C	Temp.(°C) for given Vap. Press. (mBar)			Evaporation Techniques							Sputter	Index of Refraction (@µm)	Comments		
					10 ⁸	10 ⁶	10 ⁴	E-Beam			Thermal Sources								
								Suitability	Liner	Boat	Coil	Basket	Crucible						
Beryllium Chloride	BeCl ₂	405	-	1.90	-	-	~150	-	-	-	-	-	-	-	-	RF	-	Toxic.	
Beryllium Fluoride	BeF ₂	800	S	1.99	-	-	~200	G	-	-	-	-	-	-	-	-	-	1.33@0.59	-
Beryllium Oxide	BeO	2530	-	3.01	-	-	1900	G	-	-	-	-	W	-	-	RF, RF-R	1.72@0.55	Toxic powder. No decomposition from E-beam guns.	
Bismuth	Bi	271	-	9.80	330	410	520	G	VC, Al ₂ O ₃	W, Mo, Ta, Al ₂ O ₃	W	W	W	Al ₂ O ₃ , VC	DC, RF	2.61@0.8	Toxic vapor. High resistivity. No shorting of baskets.		
Bismuth Fluoride	BiF ₃	727	S	5.32	-	-	~300	-	-	-	-	-	-	-	RF	1.7@0.55	Toxic.		
Bismuth Oxide	Bi ₂ O ₃	860	-	8.55	-	-	~1400	P	-	Pt	-	-	Pt	-	RF, RF-R	1.9@0.55	Toxic vapor.		
Bismuth Selenide	Bi ₂ Se ₃	710	D	6.82	-	-	~650	G	Gr	-	-	-	Gr, Q	RF	-	-	Toxic. Co-evaporate from two sources or sputter.		
Bismuth Sulfide	Bi ₂ S ₃	685	D	7.39	-	-	-	-	-	-	-	-	-	RF	1.5	-	Toxic.		
Bismuth Telluride	Bi ₂ Te ₃	573	D	7.7	-	-	~600	-	Gr	W, Mo	-	-	Gr, Q	RF	-	-	Toxic. Co-evaporate from two sources or sputter.		
Bismuth Titanate	Bi ₂ Ti ₂ O ₇	-	D	-	-	-	-	-	-	-	-	-	-	RF	-	-	Toxic. Sputter or co-evaporate from two sources in 10 ⁻² Torr oxygen.		

Material	Symbol	Melting Point (°C)	S/D	Density g/cm ³ @20°C	Evaporation Techniques						Sputter	Index of Refraction (@µm)	Comments		
					Temp.(°C) for given Vap. Press. (mBar)			E-Beam Suitability	Thermal Sources						
					10 ⁻⁸	10 ⁻⁶	10 ⁻⁴		Boat	Coil				Basket	Crucible
Boron	B	2300	-	2.34	1278	1548	1797	G	-	Gr	-	Gr, VC	RF	-	Explodes with rapid cooling. Forms carbide with Gr. Boats must be heated.
Boron Carbide	B ₄ C	2350	-	2.52	2500	2580	2650	Ex	-	-	-	-	RF	-	Similar to chromium. Films very adherent. Sputter quickly.
Boron Nitride	BN	~3000	S	2.25	-	-	~1600	P	-	-	-	-	RF, RF-R	-	Decomposes under sputtering; sensitive to thermic shocks. Sputtering preferred.
Boron Oxide	B ₂ O ₃	~450	-	1.81	-	-	~1400	G	-	Pt, Mo	-	-	-	-	-
Boron Sulfide	B ₂ S ₃	310	-	1.55	-	-	800	-	-	-	-	Gr	RF	-	-
Cadmium	Cd	321	-	8.64	64	120	180	F	Al ₂ O ₃	W, Mo, Ta	-	Al ₂ O ₃ , Q	DC, RF	1.13@0.6	Bad for vacuum systems. Low sticking coefficient.
Cadmium Antimonide	Cd ₃ Sb ₂	456	-	6.92	-	-	-	-	-	-	-	-	-	-	-
Cadmium Arsenide	Cd ₃ As ₂	721	-	6.21	-	-	-	-	-	-	-	Q	RF	-	Toxic.
Cadmium Bromide	CdBr ₂	567	-	5.19	-	-	~300	-	-	-	-	-	-	-	-
Cadmium Chloride	CdCl ₂	568	-	4.05	-	-	~400	-	-	-	-	-	-	-	-
Cadmium Fluoride	CdF ₂	1100	-	6.64	-	-	~500	-	-	-	-	-	RF	1.55@0.58	-
Cadmium Iodide	CdI ₂	387	-	5.67	-	-	~250	-	-	-	-	-	-	-	-
Cadmium Oxide	CdO	>1500	D	6.95	-	-	~530	-	-	-	-	-	RF-R	2.49@0.67	Reactive RF (O ₂ + Ar) or (O ₂ + N ₂).
Cadmium Selenide	CdSe	>1350	S	5.81	-	-	540	G	Al ₂ O ₃	Mo, Ta	-	Al ₂ O ₃ , Q	RF	2.4@0.58	Toxic. Evaporates easily.

Material	Symbol	Melting Point (°C)	S/D	Density g/cm ³ @20°C	Temp.(°C) for given Vap. Press. (mBar)			Evaporation Techniques						Sputter	Index of Refraction (@µm)	Comments
					10 ⁻³	10 ⁻⁶	10 ⁻⁴	E-Beam			Thermal Sources					
								Suitability	Liner	Boat	Coil	Basket	Crucible			
Cadmium Sulfide	CdS	1750	S	4.82	-	-	550	F	Gr, Al ₂ O ₃	W, Mo, Ta	-	W	Al ₂ O ₃ -Q	RF	2.5@0.55	Sticking coefficient affected by substrate temperature. Stoichiometry variable.
Cadmium Telluride	CdTe	1121	-	5.85	-	-	450	-	-	W, Mo, Ta	W	Ta, Mo	-	RF	2.6	Toxic. Stoichiometry depends on substrate temperature.
Calcium	Ca	839	S	1.54	272	357	459	P	Al ₂ O ₃	W	W	W	Al ₂ O ₃ -Q	-	0.29@0.58	Flammable. Corrodes in air.
Calcium Fluoride	CaF ₂	1423	-	3.18	-	-	~1100	-	-	W, Mo, Ta	W, Mo, Ta	W, Mo, Ta	Q	RF	1.4@0.55	Rate control important. Preheat gently to outgas.
Calcium Oxide	CaO	2614	-	~3.3	-	-	~1700	-	-	W, Mo	-	-	ZrO ₂	RF, RF-R	1.84@0.59	Forms volatile oxides with tungsten and molybdenum.
Calcium Silicate	CaSiO ₃	1540	-	2.91	-	-	-	G	-	-	-	-	Q	RF	-	-
Calcium Sulfide	CaS	-	D	2.5	-	-	1100	-	-	Mo	-	-	-	RF	2.14@0.59	-
Calcium Titanate	CaTiO ₃	1975	-	4.10	1490	1600	1690	P	-	-	-	-	-	RF	2.34@0.59	Disproportionates except in sputtering.
Calcium Tungstate	CaWO ₄	-	-	6.06	-	-	-	G	-	W	-	-	-	RF	1.92@0.59	-
Carbon	C	~3652	S	1.8-2.1	1677	1867	2107	G	-	-	-	-	-	RF	1.47	E-beam preferred. Arc evaporation. Poor film adhesion.
Parlylene	C ₈ H ₈	300-400	-	1.1	-	-	-	-	-	-	-	-	-	-	-	Vapor-depositable plastic.

Material	Symbol	Melting Point (°C)	S/D	Density g/cm ³ @20°C	Temp.(°C) for given Vap. Press. (mBar)			Evaporation Techniques						Sputter	Index of Refraction (@µm)	Comments
					10 ⁸	10 ⁶	10 ⁻⁴	E-Beam		Thermal Sources						
								Suitability	Liner	Boat	Coil	Basket	Crucible			
Cerium	Ce	798	-	~6.70	970	1150	1380	G	Al ₂ O ₃ , VC	W, Ta	W	W, Ta	Al ₂ O ₃ , VC	DC, RF	1.91@0.59	Films oxide easily.
Cerium Fluoride	CeF ₃	1460	-	6.16	-	-	~900	G	-	W, Mo, Ta	-	Mo, Ta	-	RF	1.63@0.55	Preheat gently to outgas.
Cerium (III) Oxide	Ce ₂ O ₃	1692	-	6.86	-	-	-	F	-	W	-	-	-	-	2.18@0.58	Allays with source. Use 0.015 "-0.020" tungsten boat. E-beam gun preferred.
Cerium (IV) Oxide	CeO ₂	~2600	S	7.13	1890	2000	2310	G	Gr	W	-	-	-	RF, RF-R	2.18@0.55	Very little decomposition. Use 250°C substrate temperature.
Cesium	Cs	28	-	1.88	-17	22	75	-	-	SS	-	-	Q	-	-	Flammable.
Cesium Bromide	CsBr	636	-	3.04	-	-	~400	-	-	W	-	-	-	RF	-	-
Cesium Chloride	CsCl	645	-	3.99	-	-	~500	-	-	W	-	-	-	RF	-	Hygroscopic.
Cesium Fluoride	CsF	682	-	4.12	-	-	~500	-	-	W	-	-	-	RF	1.5@0.55	-
Cesium Hydroxide	CsOH	272	-	3.68	-	-	550	-	-	Pt	-	-	-	-	-	-
Cesium Iodide	CsI	626	-	4.51	-	-	~500	-	-	W	-	-	-	RF	1.99@0.23	-
Chromium	Cr	1857	S	7.20	852	977	1162	G	Gr, VC	**	W	W	VC	RF, DC	3.28@0.7	Films very adherent. High rates possible.
Chromium Boride	CrB	2760	-	6.17	-	-	-	-	-	-	-	-	-	RF, DC	-	-
Chromium Bromide	CrBr ₂	842	-	4.36	-	-	550	-	-	-	-	-	-	RF	-	-
Chromium Carbide	Cr ₃ C ₂	1980	-	6.68	-	-	~2000	F	-	W	-	-	-	RF, DC	-	-
Chromium Chloride	CrCl ₂	824	-	2.88	-	-	550	-	-	Fe	-	-	-	RF	-	Sublimes easily.
Chromium Oxide	Cr ₂ O ₃	2266	-	5.21	-	-	~2000	G	-	W, Mo	-	W	-	RF, RF-R	2.55@0.59	Disproportionates to lower oxides; reoxidizes at 600°C in air.
Chromium Silicide	Cr ₃ Si ₂	-	-	5.5	-	-	-	-	-	-	-	-	-	RF, DC	-	-
Chromium-Silicon Monoxide	Cr-SiO	-	-	*	*	*	*	G	-	W	-	W	-	DC, RF	-	Flash.

Material	Symbol	Melting Point (°C)	S/D	Density g/cm ³ @20°C	Temp.(°C) for given Vap. Press. (mBar)			Evaporation Techniques						Sputter	Index of Refraction (@µm)	Comments
					10 ⁻³	10 ⁻⁶	10 ⁻⁴	E-Beam			Thermal Sources					
								Suitability	Liner	Boat	Coil	Basket	Crucible			
Cobalt	Co	1495	-	8.9	927	1072	1262	Ex	Al ₂ O ₃	W	-	W	Al ₂ O ₃	DC, RF	2.17@0.62	Alloys with refractory metals.
Cobalt Bromide	CoBr ₂	678	S	4.91	-	-	400	-	-	-	-	-	-	RF	-	-
Cobalt Chloride	CoCl ₂	724	S	3.36	-	-	472	-	-	-	-	-	-	RF	1.51@0.63	-
Cobalt Oxide	CoO	1795	-	6.45	-	-	-	-	-	-	-	-	-	DC-R, RF-R	-	Sputter preferred.
Copper	Cu	1083	-	8.92	727	857	1017	Ex	Cr, Al ₂ O ₃ , Mo, Ta	Mo	W	W	Al ₂ O ₃ Int	DC, RF	0.17@0.8	Adhesion poor. Use interlayer (Cr). Evaporates using any source material.
Copper Chloride	CuCl	430	-	4.14	-	-	~600	-	-	-	-	-	-	RF	1.93	-
Copper Oxide	Cu ₂ O	1235	S	6.0	-	-	~600	G	Al ₂ O ₃	Ta	-	-	Al ₂ O ₃	DC-R, RF-R	2.71@0.59	Evaporate in 10 ⁻² to 10 ⁻⁴ of O ₂ .
Copper Sulfide	Cu ₂ S	1100	-	5.6	-	-	-	-	-	-	-	-	-	-	-	-
Dysprosium	Dy	1412	S	8.55	625	750	900	G	-	Ta	-	-	-	RF, DC	-	Flammable.
Dysprosium Fluoride	DyF ₃	1360	S	-	-	-	~800	G	-	Ta	-	-	-	RF	1.6@0.55	-
Dysprosium Oxide	Dy ₂ O ₃	2340	-	7.81	-	-	~1400	-	-	Ir	-	-	-	RF, RF-R	1.9@0.55	Loses oxygen.
Erbium	Er	1529	S	9.07	650	775	930	G	-	W, Ta	-	-	-	DC, RF	-	-
Erbium Fluoride	ErF ₃	1350	-	-	-	-	~750	-	-	-	-	-	-	RF	1.5@0.55	-
Erbium Oxide	Er ₂ O ₃	Infus.	-	8.64	-	-	~1600	-	-	Ir	-	-	-	RF, RF-R	1.9@0.55	Loses oxygen.

Material	Symbol	Melting Point (°C)	S/D	Density g/cm ³ @20°C	Temp.(°C) for given Vap. Press. (mBar)			Evaporation Techniques					Sputter	Index of Refraction (@µm)	Comments		
					10 ⁸	10 ⁶	10 ⁻⁴	E-Beam		Thermal Sources							
								Suitability	Liner	Boat	Coil	Basket				Crucible	
Europium	Eu	822	-	5.24	280	360	460	F	Al ₂ O ₃	W, Ta	-	-	-	Al ₂ O ₃	RF, DC	-	Flammable. Low tantalum solubility.
Europium Fluoride	EuF ₂	1380	-	6.50	-	-	~950	-	-	Mo	-	-	-	-	RF	-	-
Europium Oxide	Eu ₂ O ₃	-	-	7.42	-	-	~1600	G	W	Ir, Ta, W	-	-	-	ThO ₂	RF, RF-R	1.9@0.55	Loses oxygen. Films clear and hard.
Europium Sulfide	EuS	-	-	5.75	-	-	-	G	-	-	-	-	-	-	RF	-	-
Gadolinium	Gd	1313	-	7.90	760	900	1175	Ex	Al ₂ O ₃	Ta	-	-	-	Al ₂ O ₃	RF, DC	-	Flammable. High tantalum solubility.
Gadolinium Carbide	GdC ₂	-	-	-	-	-	1500	-	-	-	-	-	-	Gr	RF	-	Decomposes under sputtering.
Gadolinium Oxide	Gd ₂ O ₃	2330	-	7.41	-	-	-	F	-	Ir	-	-	-	-	RF, RF-R	1.8@0.55	Loses oxygen.
Gallium	Ga	30	-	5.90	619	742	907	G	Gr, VC, Al ₂ O ₃	-	-	-	-	Al ₂ O ₃ , Q	-	-	Alloys with refractory metals. Use E-beam gun. Attack crucibles above 1000°C.
Gallium Antimonide	GaSb	710	-	5.6	-	-	-	F	-	W, Ta	-	-	-	-	RF	3.8@2.2	Flash evaporate.
Gallium Arsenide	GaAs	1238	-	5.3	-	-	-	G	Gr	W, Ta	-	-	-	Gr	RF	3.34@0.78	Flash evaporate.
Gallium Nitride	GaN	800	S	6.1	-	-	~200	-	-	-	-	-	-	Al ₂ O ₃	RF, RF-R	-	Evaporates gallium in 10 ⁻³ Torr nitrogen.
Gallium Oxide	Ga ₂ O ₃	1900	-	6.44	-	-	-	-	-	Pr, W	-	-	-	-	RF	-	Loses oxygen.
Gallium Phosphide	GaP	1540	-	4.1	-	770	920	-	-	W, Ta	-	-	W	Q	RF	3@2.15	Does not decompose. Rate control important.

Material	Symbol	Melting Point (°C)	S/D	Density g/cm ³ @20°C	Temp.(°C) for given Vap. Press. (mBar)			Evaporation Techniques						Sputter	Index of Refraction (@µm)	Comments	
					10 ⁻⁸	10 ⁻⁶	10 ⁻⁴	E-Beam			Thermal Sources						
								Suitability	Liner	Boat	Coil	Basket	Crucible				
Germanium	Ge	937	-	5.35	812	952	1142	Ex	Gr, Al ₂ O ₃	W, Gr, Ta	-	-	-	Q, Al ₂ O ₃	DC, RF	4@2	Excellent films from E-beam guns. Wets W, Ta and Mo.
Germanium Nitride	Ge ₃ N ₂	450	S	5.2	-	-	~650	-	-	-	-	-	-	-	RF-R	-	Sputtering preferred.
Germanium (II) Oxide	GeO	710	-	-	-	-	500	-	-	-	-	-	Q	-	RF	-	-
Germanium (III) Oxide	GeO ₂	1086	-	6.24	-	-	~625	G	VC, Al ₂ O ₃	Ta, Mo	-	-	W, Mo	Q, Al ₂ O ₃	RF-R	1.61@0.59	Similar to SiO ₂ film predominantly GeO.
Germanium Telluride	GeTe	725	-	6.20	-	-	381	-	-	W, Mo	-	-	W	Q, Al ₂ O ₃	RF	-	-
Glass, Schott 8329	-	-	-	2.20	-	-	-	Ex	-	-	-	-	-	-	RF	1.47	Evaporable alkali glass. Melt in air before evaporating.
Gold	Au	1064	-	19.32	807	947	1132	Ex	Gr, VC, Al ₂ O ₃ , BN	W	W	-	W,*** Mo,***	Al ₂ O ₃ , BN, VC	DC, RF	0.2@0.6	Films soft, not very adherent. Wets W and Mo. Sputtering preferred.
Hafnium	Hf	2227	-	13.31	2160	2250	3090	G	Mo	-	-	-	-	-	DC, RF	-	-
Hafnium Boride	HfB ₂	3250	-	10.5	-	-	-	-	-	-	-	-	-	-	DC, RF	-	-
Hafnium Carbide	HfC	~3890	S	12.20	-	-	~2600	-	-	-	-	-	-	-	DC, RF	-	-
Hafnium Nitride	HfN	3305	-	-	-	-	-	-	-	-	-	-	-	-	RF, RF-R	-	-
Hafnium Oxide	HfO ₂	2758	-	9.68	-	-	~2500	F	Mo	W	-	-	-	-	DC, RF, RF-R	1.9@0.55	Film HfO.
Hafnium Silicide	HfSi ₂	1750	-	7.2	-	-	-	-	-	-	-	-	-	RF	-	-	-

Material	Symbol	Melting Point (°C)	S/D	Density g/cm ³ @20°C	Temp.(°C) for given Vap. Press. (mBar)			Evaporation Techniques					Sputter	Index of Refraction (@µm)	Comments		
					10 ⁸	10 ⁶	10 ⁻⁴	E-Beam		Thermal Sources							
								Suitability	Liner	Boat	Coil	Basket				Crucible	
Holmium	Ho	1474	S	8.80	650	770	950	G	-	W, Ta	W	W	-	-	-	-	
Holmium Fluoride	HoF ₃	1143	-	-	-	-	~800	-	-	-	-	-	Q	DC, RF	1.6@0.55	-	
Holmium Oxide	Ho ₂ O ₃	2370	-	8.41	-	-	-	-	-	Ir	-	-	-	RF, RF-R	1.9@0.55	Loses oxygen.	
Indium	In	157	-	7.30	487	597	742	Ex	Gr, Al ₂ O ₃ , Mo	W, Mo	-	W	Gr, Al ₂ O ₃	DC, RF	1.38@0.71	Wets tungsten and copper.	
Indium Antimonide	InSb	535	D	5.8	-	-	-	-	-	W	-	-	-	RF	1@0.55	Toxic. Sputter preferred or co-evaporate on heated substrat 900°C. Flash.	
Indium Arsenide	InAs	943	D	5.7	780	870	970	-	-	W	-	-	-	RF	4.5@1	Toxic. Sputtering preferred or co-evap from 2 sources. Flash.	
Indium Nitride	InN	1200	-	7.0	-	-	-	-	-	-	-	-	-	RF	-	-	
Indium (I) Oxide	In ₂ O	~600	S	6.99	-	-	650	-	-	-	-	-	-	RF	-	Decomposes under sputtering.	
Indium (III) Oxide	In ₂ O ₃	850	-	7.18	-	-	~1200	G	Al ₂ O ₃	W, Pt	-	-	Al ₂ O ₃	-	2@0.55	Film In ₂ O. Transparent conductor.	
Indium Phosphide	InP	1070	-	4.8	-	630	730	-	-	W, Ta	-	W, Ta	Gr	RF	3@2	Deposits are phosphorus rich. Flash evaporate.	
Indium Selenide	In ₂ Se ₃	890	-	5.67	-	-	-	-	-	-	-	-	-	RF	-	Sputtering preferred; or co-evaporate from two sources; flash.	
Indium (I) Sulfide	In ₂ S	653	-	5.87	-	-	650	-	-	-	-	-	Gr	RF	2	-	
Indium (II) Sulfide	InS	692	S	5.18	-	-	650	-	-	-	-	-	Gr	RF	-	-	
Indium (III) Sulfide	In ₂ S ₃	1050	S	4.90	-	-	850	-	-	-	-	-	Gr	RF	-	Film In ₂ S.	
Indium (II) Telluride	InTe	696	-	6.29	-	-	-	-	-	-	-	-	-	-	-	-	-

Material	Symbol	Melting Point (°C)	S/D	Density g/cm ³ @20°C	Temp.(°C) for given Vap. Press. (mBar)			Evaporation Techniques						Sputter	Index of Refraction (@µm)	Comments
					10 ⁻⁸	10 ⁻⁶	10 ⁻⁴	E-Beam			Thermal Sources					
								Suitability	Liner	Boat	Coil	Basket	Crucible			
Indium (III) Telluride	In ₂ Te ₃	667	-	5.78	-	-	-	-	-	-	-	-	-	-	-	Sputtering preferred; or co-evaporate from two sources; flash.
Indium Tin Oxide (ITO)	In ₂ O ₃ -SnO ₂	1800	S	7.1	-	-	600	Ex	Mo	-	-	-	-	-	-	Loses oxygen.
Iridium	Ir	2410	-	22.42	1850	2080	2380	F	W	-	-	-	-	DC, RF	-	-
Iron	Fe	1535	-	7.86	877	1017	1207	Ex	VC, Al ₂ O ₃	W	W	W	W	DC, RF	2@0.58	Attacks tungsten. Films hard, smooth. Preheat gently to outgas.
Iron Bromide	FeBr ₂	684	-	4.64	-	-	561	-	-	-	-	-	-	RF	-	-
Iron Chloride	FeCl ₂	670	S	3.16	-	-	300	-	-	-	-	-	-	RF	1.57@0.59	-
Iron Iodide	FeI ₂	-	-	5.32	-	-	400	-	-	-	-	-	-	RF	-	-
Iron (II) Oxide	FeO	1369	D	5.7	-	-	-	P	-	-	-	-	-	RF, RF-R	2.32@0.59	Sputtering preferred.
Iron (III) Oxide	Fe ₂ O ₃	1565	-	5.24	-	-	-	G	-	W	-	-	-	-	3@0.55	Disproportionates to Fe ₃ O ₄ at 1530°C.
Iron Sulfide	FeS	1193	D	4.74	-	-	-	-	-	-	-	-	-	RF	-	-
Kanthal	FeCrAl	-	-	7.1	-	-	-	-	-	W	W	W	-	DC, RF	1.74@0.58	-
Lanthanum	La	921	-	6.15	990	1212	1388	Ex	Al ₂ O ₃	W, Ta	-	-	-	RF	-	Films will burn in air if scraped.
Lanthanum Boride	LaB ₆	2210	-	2.61	-	-	-	G	-	-	-	-	-	RF	-	Toxic.
Lanthanum Bromide	LaBr ₃	783	-	5.06	-	-	-	-	-	-	-	Ta	-	RF	-	Hygroscopic.
Lanthanum Fluoride	LaF ₃	1490	S	~6.0	-	-	900	G	-	Ta, Mo	-	-	-	RF	1.6@0.55	No decomposition. Heat substrate over 300°C.
Lanthanum Oxide	La ₂ O ₃	2307	-	6.51	-	-	1400	G	-	W, Ta	-	-	-	RF	1.9@0.55	Loses oxygen.

Material	Symbol	Melting Point (°C)	S/D	Density g/cm ³ @20°C	Temp.(°C) for given Vap. Press. (mBar)			Evaporation Techniques					Sputter	Index of Refraction (@µm)	Comments	
					10 ⁸	10 ⁶	10 ⁻⁴	E-Beam		Thermal Sources						Crucible
								Suitability	Liner	Boat	Coil	Basket				
Lead	Pb	328	-	11.34	342	427	497	Ex	Gr, Al ₂ O ₃	W, Mo	W	W, Ta	Al ₂ O ₃ , Q	DC, RF	1.51@0.8	Toxic.
Lead Bromide	PbBr ₂	373	-	6.66	-	-	~300	-	-	-	-	-	-	-	-	Toxic.
Lead Chloride	PbCl ₂	501	-	5.85	-	-	~325	-	-	Pt	-	-	Al ₂ O ₃	RF	2.3@0.55	Toxic. Little decomposition.
Lead Fluoride	PbF ₂	855	S	8.24	-	-	~400	-	-	W, Pt, Mo	-	-	Al ₂ O ₃	RF	1.75@0.55	Toxic.
Lead Oxide	PbO	886	-	9.53	-	-	550	-	-	Mo, Pt	-	-	Q, Al ₂ O ₃	RF-R	2.51@0.59	No decomposition.
Lead Selenide	PbSe	1065	S	8.1	-	-	500	-	-	Mo, W	-	W	Gr, Al ₂ O ₃	RF	3.5@1.0	-
Lead Sulfide	PbS	1114	S	7.5	-	-	500	-	-	W	-	W, Mo	Q, Al ₂ O ₃	RF	3.9@0.5	Little decomposition.
Lead Telluride	PbTe	917	-	8.16	780-	910-	1050	-	-	Mo, Pt, Ta	-	-	Al ₂ O ₃ , Gr	RF	5.6@5 / 3.4@30-	Deposits are ta rich. Sputtering preferred.
Lead Titanate	PbTiO ₃	-	-	7.52	-	-	-	-	-	Ta	-	-	-	RF	-	-
Lithium	Li	181	-	0.53	227	307	407	G	Al ₂ O ₃	Ta, SS	-	-	Al ₂ O ₃	-	-	Metal reacts quickly in air.
Lithium Bromide	LiBr	550	-	3.46	-	-	~500	-	-	Ni	-	-	-	RF	1.78@0.59	-
Lithium Chloride	LiCl	613	-	2.07	-	-	400	-	-	Ni-	-	-	-	RF	1.66@0.59	Use gently preheat for outgas.
Lithium Fluoride	LiF	870	-	2.6	875	1020	1180	G	Ta, W, Mo	Ni, Ta, Mo, W	-	-	Al ₂ O ₃	RF	1.44@0.19 / 1.36@3.5	Toxic. Preheat gently to outgas. Evaporates well.
Lithium Iodide	LiI	449	-	4.08	-	-	400	-	-	Mo, W	-	-	-	RF	1.96@0.59	-
Lithium Oxide	Li ₂ O	>1700	-	2.01	-	-	850	-	-	Pt, Ir	-	-	-	RF	1.64@0.59	-
Lutetium	Lu	1663	S	9.84	-	-	1300	Ex	Al ₂ O ₃	Ta	-	-	Al ₂ O ₃	RF, DC	-	-
Lutetium Oxide	Lu ₂ O ₃	-	D	9.42	-	-	1400	-	-	Ir	-	-	-	RF	1.9@0.55	-
Magnesium	Mg	649	S	1.74	185	247	327	G	VC, Al ₂ O ₃	W, Mo, Ta	W	W	Al ₂ O ₃ , VC	DC, RF	0.52@0.4	Flammable. Extremely high rates possible. Sputtering possible but enough slow.
Magnesium Aluminate	MgAl ₂ O ₄	2135	-	3.6	-	-	-	G	-	-	-	-	-	RF	-	Natural spinel.

Material	Symbol	Melting Point (°C)	S/D	Density g/cm ³ @20°C	Temp.(°C) for given Vap. Press. (mBar)			Evaporation Techniques						Sputter	Index of Refraction (@µm)	Comments		
					10 ⁻⁸	10 ⁻⁶	10 ⁻⁴	E-Beam			Thermal Sources							
								Suitability	Liner	Boat	Coil	Basket	Crucible					
Magnesium Bromide	MgBr ₂	700	D	3.72	-	-	~450	-	-	Ni	-	-	-	-	RF	-	-	
Magnesium Chloride	MgCl ₂	714	D	2.32	-	-	400	-	-	Ni	-	-	-	-	RF	1.6	-	
Magnesium Fluoride	MgF ₂	1261	-	2.9-3.2	-	-	1000	Ex	Al ₂ O ₃ , Mo	-	-	-	-	-	RF	1.38@0.55	Rate control and substrate heat important for optical films. Reacts with tungsten. Excellent with molybdenum.	
Magnesium Iodide	MgI ₂	<637	-	4.43	-	-	200	-	-	Pr	-	-	-	-	RF	-	-	
Magnesium Oxide	MgO	2852	-	3.58	-	-	1300	G	Al ₂ O ₃	-	-	-	-	-	RF, RF-R	1.7@0.55	Evaporates in 10 ⁻³ Torr oxygen for stoichiometry. Tungsten gives volatile oxides.	
Manganese	Mn	1244	S	7.20	507	572	647	G	Al ₂ O ₃	W, Ta, Mo	W	W	W	DC, RF	2.59@0.59	Flammable. Wets refractair metals.		
Manganese Bromide	MnBr ₂	-	-	4.39	-	-	500	-	-	-	-	-	-	RF	-	-	-	
Manganese Chloride	MnCl ₂	650	-	2.98	-	-	450	-	-	-	-	-	-	RF	-	-	-	
Manganese (III) Oxide	Mn ₂ O ₃	1080	-	4.50	-	-	-	-	-	-	-	-	-	-	-	-	-	
Manganese (IV) Oxide	MnO ₂	535	-	5.03	-	-	-	P	-	W	-	-	W	RF-R	-	-	Loses oxygen at 535°C.	
Manganese Sulfide	MnS	-	D	3.99	-	-	1300	-	-	Mo	-	-	-	RF	2.7	-	-	
Mercury	Hg	-39	-	13.55	-68	-42	-6	-	-	-	-	-	-	-	-	-	-	Toxic.
Mercury Sulfide	HgS	584	S/D	8.10	-	-	250	-	-	-	-	-	-	RF	-	-	-	Toxic.

Material	Symbol	Melting Point (°C)	S/D	Density g/cm ³ @20°C	Temp.(°C) for given Vap. Press. (mBar)						Evaporation Techniques						Sputter	Index of Refraction (@µm)	Comments
					10 ⁸		10 ⁶		10 ⁻⁴		E-Beam			Thermal Sources					
					10 ⁸	10 ⁶	10 ⁸	10 ⁶	10 ⁸	10 ⁶	10 ⁻⁴	Suitability	Liner	Boat	Coil	Basket			
Molybdenum	Mo	2610	-	10.2	1592	1822	2117	Ex	Gr	-	-	-	-	-	DC, RF	3.65@0.59	Films smooth, hard. Careful degas required.		
Molybdenum Boride	MoB ₂	2100	-	7.12	-	-	-	P	-	-	-	-	-	RF, DC	-	-	-		
Molybdenum Carbide	Mo ₂ C	2687	-	8.9	-	-	-	F	-	-	-	-	-	RF, DC	-	Evaporation of Mo(CO) ₆ yields Mo ₂ C.	-		
Molybdenum Disulfide	MoS ₂	1185	-	4.80	-	-	~50	-	-	-	-	-	-	RF	-	-	-		
Molybdenum Oxide	MoO ₃	795	-	4.69	-	-	~900	-	Al ₂ O ₃ , Mo	Mo, Pt	-	-	-	RF	1.9@0.55	Slight oxygen loss.			
Molybdenum Silicide	MoSi ₂	2050	D	6.31	-	-	-	-	-	W	-	-	-	RF	1.9	Slight O ₂ loss.			
Neodymium	Nd	1021	-	7.01	731	871	1062	Ex	Al ₂ O ₃	Ta	-	-	-	DC, RF	0.3@0.88	Flammable. Low tantalum solubility.			
Neodymium Fluoride	NdF ₃	1410	-	6.5	-	-	~900	G	Al ₂ O ₃	Mo, W	-	-	Mo, Ta	RF	1.61@0.55	Very little decomposition.			
Neodymium Oxide	Nd ₂ O ₃	~1900	-	7.24	-	-	~1400	G	W	Ta, W	-	-	-	RF, RF-R	2@0.55	Loses oxygen. Films clear. E-beam preferred. Hygroscopic. N varies with substrate temperature.			
Nickel	Ni	1455	-	8.90	927	1072	1262	Ex	VC, Al ₂ O ₃	W	W	W	W	DC, RF	2.37@0.81	Alloys with refractory metals. Forms smooth adherent films.			
Nickel Bromide	NiBr ₂	963	S	5.10	-	-	362	-	-	-	-	-	-	RF	-	-	-		
Nickel Chloride	NiCl ₂	1001	S	3.55	-	-	444	-	-	-	-	-	-	RF	-	-	-		
Nickel Oxide	NiO	1984	-	6.67	-	-	~1470	-	Al ₂ O ₃	-	-	-	-	RF-R	2.18@0.48	Dissociates on heating.			
Inconel	Ni/Cr/Fe	1425	-	8.5	-	-	-	G	-	W	W	W	W	DC, RF	-	Use fine wire wrapped on tungsten. Low rate required for smooth films.			

Material	Symbol	Melting Point (°C)	S/D	Density g/cm ³ @20°C	Temp.(°C) for given Vap. Press. (mBar)			Evaporation Techniques						Sputter	Index of Refraction (@µm)	Comments
					10 ⁻⁸	10 ⁻⁶	10 ⁻⁴	E-Beam			Thermal Sources					
								Suitability	Liner	Boat	Coil	Basket	Crucible			
Nichrome IV	Ni/Cr	1395	-	8.50	847	987	1217	Ex	Gr, VC, Al ₂ O ₃	***	W	W, Ta	Al ₂ O ₃ , VC	DC, RF	3.74@8.8	Alloys with refractory metals.
Permalloy	Ni/Fe	1395	-	8.7	947	1047	1307	G	VC, Al ₂ O ₃	W	-	-	Al ₂ O ₃ , VC	DC, RF	-	Film low in nickel. Use 84% Ni source.
Supermalloy	Ni/Fe/Mo	1410	-	8.9	-	-	-	G	-	-	-	-	-	RF, DC	-	Sputtering preferred; or co-evaporate from two sources, permalloy and molybdenum.
Supermalloy	Ni/Fe/Mo/Mn	1395	-	8.7	947	1047	1307	G	Gr	W	-	-	Al ₂ O ₃	DC	-	Film poor in Ni.
Niobium	Nb	2468	-	8.57	1728	1977	2287	Ex	-	W	-	-	-	DC, RF	1.8@0.58	Attacks tungsten source.
Niobium Boride	NbB ₂	3050	-	6.97	-	-	-	-	-	-	-	-	-	RF, DC	-	-
Niobium Carbide	NbC	3500	-	7.6	-	-	-	F	-	-	-	-	-	RF, DC	-	-
Niobium Nitride	NbN	2573	-	8.4	-	-	-	-	-	-	-	-	-	RF, RF-R	-	Sputters reactive or evaporates niobium in 10 ⁻³ Torr nitrogen.
Niobium (II) Oxide	NbO	-	-	7.30	-	-	1100	-	-	Pt	-	-	-	RF	-	-
Niobium (III) Oxide	Nb ₂ O ₃	1780	-	7.5	-	-	-	-	-	W	-	W	-	RF, RF-R	-	-
Niobium (V) Oxide	Nb ₂ O ₅	1485	-	4.47	-	-	-	-	-	W	-	W	-	RF, RF-R	2.3@0.55	-
Niobium Stannide	Nb ₃ Sn	-	-	-	-	-	-	Ex	-	-	-	-	-	RF, DC	-	Co-evaporate from two sources.
Niobium Telluride	NbTe _x	-	-	7.6	-	-	-	-	-	-	-	-	-	RF	-	Composition variable.
Osmium	Os	2700	-	22.48	2170	2430	2760	F	-	-	-	-	-	DC, RF	-	Toxic.
Osmium Oxide	Os ₂ O ₃	-	D	-	-	-	-	-	-	-	-	-	-	-	-	Deposits osmium in 10 ⁻³ Torr oxygen.

Material	Symbol	Melting Point (°C)	S/D	Density g/cm ³ @20°C	Evaporation Techniques						Sputter	Index of Refraction (@µm)	Comments			
					Temp.(°C) for given Vap. Press. (mBar)			E-Beam Suitability	Liner	Boat				Thermal Sources		
					10 ⁸	10 ⁶	10 ⁻⁴							Coil	Basket	Crucible
Palladium	Pd	1554	S	12.02	842	992	1192	Ex	Gr, Al ₂ O ₃	W	W	W	Al ₂ O ₃	DC, RF	2.3@0.54	Alloys with refractory metals. Rapid evaporation suggested. Splits in E-beam.
Palladium Oxide	PdO	870	D	9.70	-	-	575	-	Al ₂ O ₃	-	-	-	Al ₂ O ₃	RF-R	-	-
Phosphorus	P	44.1	-	1.82	54	88	129	-	-	-	-	-	Al ₂ O ₃	-	-	Material reacts violently in air.
Phosphorus Nitride	P ₃ N ₅	-	-	2.51	-	-	-	-	-	-	-	-	-	RF, RF-R	-	-
Platinum	Pt	1772	-	21.45	1292	1492	1747	Ex	Gr, W	W	W, Pt	W	Gr, W	DC, RF	3.42@1.0	Alloys with metals. Films soft, poor adhesion. E-beam required.
Platinum Oxide	PtO ₂	450	-	10.2	-	-	-	-	-	-	-	-	-	RF-R	-	-
Plutonium	Pu	641	-	19.84	-	-	-	-	-	W	-	-	-	DC, RF	-	Toxic, radioactive.
Polonium	Po	254	-	9.4	117	170	244	-	-	-	-	-	Q	-	-	Radioactive.
Potassium	K	63	-	0.86	23	60	125	-	-	Mo	-	-	Q	-	0.74@0.25	Metal reacts rapidly in air. Preheat gently to outgas.
Potassium Bromide	KBr	734	-	2.75	-	-	~450	-	-	Ta, Mo	-	-	Q	RF	1.56@0.48	Preheat gently to outgas.
Potassium Chloride	KCl	770	-	1.98	-	-	510	F	-	Ta, Ni	-	-	-	RF	1.72@0.2	Preheat gently to outgas.
Potassium Fluoride	KF	858	-	2.48	-	-	~500	P	-	-	-	-	Q	RF	1.35@1.4	Preheat gently to outgas.
Potassium Hydroxide	KOH	360	-	2.04	-	-	~400	-	-	Pt	-	-	-	-	-	Preheat gently to outgas. Hygroscopic.

Material	Symbol	Melting Point (°C)	S/D	Density g/cm ³ @20°C	Temp.(°C) for given Vap. Press. (mBar)			Evaporation Techniques						Sputter	Index of Refraction (@µm)	Comments
					10 ⁻⁸	10 ⁻⁶	10 ⁻⁴	E-Beam			Thermal Sources					
								Suitability	Liner	Boat	Coil	Basket	Crucible			
Potassium Iodide	KI	681	-	3.13	-	-	~500	-	-	Ta	-	-	-	RF	1.92@0.27	Preheat gently to outgas.
Praseodymium	Pr	931	-	6.77	800	950	1150	F	-	Ta	-	-	-	RF, DC	-	Flammable.
Praseodymium Oxide	Pr ₂ O ₃	-	-	7.07	-	-	1400	G	W	Ir	-	-	W	RF, RF-R	2@0.55	Loses oxygen.
Radium	Ra	700	-	5	246	320	416	-	-	-	-	-	-	-	-	-
Rhenium	Re	3180	-	20.53	1928	2207	2571	G	-	-	-	-	-	DC, RF	3.18@0.59	Fine wire will self-evaporate.
Rhenium Oxide	ReO ₃	-	-	~7	-	-	-	-	-	-	-	-	-	RF	-	Evaporate rhenium in 10 ⁻³ Torr.
Rhodium	Rh	1966	-	12.4	1277	1472	1707	G	VC, W	W	W	W	W, VC	DC, RF	2.03@0.8	E-beam gun preferred.
Rubidium	Rb	39	-	1.48	-3	37	111	-	-	-	-	-	Q	DC, RF	1.03@0.25	-
Rubidium Chloride	RbCl	718	-	2.09	-	-	~550	-	-	-	-	-	Q	RF	1.49	-
Rubidium Iodide	RbI	647	-	3.55	-	-	~400	-	-	-	-	-	Q	RF	1.68@0.58	-
Ruthenium	Ru	2310	-	12.3	1780	1990	2260	P	-	W	-	-	-	DC, RF	-	Spit violently in E-beam. Require long degas.
Samarium	Sm	1074	-	7.52	373	460	573	G	Al ₂ O ₃	Ta	-	-	Al ₂ O ₃	RF, DC	-	-
Samarium Oxide	Sm ₂ O ₃	2350	-	8.35	-	-	-	G	W	Ir	-	-	W	RF, RF-R	1.9@0.55	Loses oxygen. Films smooth, clear.
Samarium Sulfide	Sm ₂ S ₃	1900	-	5.73	-	-	-	G	-	-	-	-	-	-	-	-

Material	Symbol	Melting Point (°C)	S/D	Density g/cm ³ @20°C	Temp.(°C) for given Vap. Press. (mBar)				Evaporation Techniques						Index of Refraction (@µm)	Comments				
					10 ⁸		10 ⁶		10 ⁻⁴		Thermal Sources									
					10 ⁸	10 ⁶	10 ⁸	10 ⁶	10 ⁸	10 ⁶	E-Beam Suitability	Liner	Boat	Coil			Basket	Crucible		
Scandium	Sc	1541	S	2.99	714	920	1100	Ex	Al ₂ O ₃	W	-	-	-	-	-	-	Al ₂ O ₃	RF	-	Flammable. Alloys with tantalum.
Scandium Oxide	Sc ₂ O ₃	2300	-	3.86	-	-	~400	F	-	-	-	-	-	-	-	-	-	RF, RF-R	1.89@0.55	Loses oxygen.
Selenium	Se	217	-	4.81	89	125	170	G	Gr, VC, Al ₂ O ₃	W, Mo	W, Mo	W, Mo	W, Mo	W, Mo	W, Mo	Al ₂ O ₃ , VC	RF, DC	2.78	Toxic. Bad for vacuum systems. Wets all sources.	
Silicon	Si	1410	-	2.32	992	1147	1337	G	VC, Ta	W, Ta, Mo	-	-	-	-	-	-	BeO, Ta, VC	DC, RF	4.06@0.8	Alloys with tungsten; use heavy tungsten boat. SiO produced above 4.10 ⁶ Torr. E-beam preferred.
Silicon Boride	SiB ₄	-	-	-	-	-	-	P	-	-	-	-	-	-	-	-	-	RF	-	-
Silicon Carbide	SiC	~2700	-	3.22	-	-	1000	-	-	-	-	-	-	-	-	-	-	RF	2.7@0.55	Sputtering preferred.
Silicon Nitride	Si ₃ N ₄	1900	S	3.44	-	-	~800	-	-	-	-	-	-	-	-	-	-	RF, RF-R	2@0.12	-
Silicon (II) Oxide	SiO	>1702	S	2.13	-	-	850	G	Gr, Ta	Ta	W	W	Ta	W	-	Ta	RF, RF-R	1.9@2	-	For resistance evaporation, use baffle box and low rate. E-beam preferred.
Silicon (IV) Oxide	SiO ₂	1610	-	~2.65	*	*	1025*	Ex	Gr, Al ₂ O ₃ , Mo	-	-	-	-	-	-	Al ₂ O ₃	RF	1.46@0.55	Quartz excellent in E-beam.	
Silicon Selenide	SiSe	-	-	-	-	-	550	-	-	-	-	-	-	-	-	Q	RF	-	-	Toxic.
Silicon Sulfide	SiS	940	S	1.85	-	-	450	-	-	-	-	-	-	-	-	Q	RF	-	-	-
Silicon Telluride	SiTe ₂	-	-	4.39	-	-	550	-	-	-	-	-	-	-	-	Q	RF	-	-	Toxic.
Silver	Ag	962	-	10.5	574	685	832	Ex	Gr, VC, Al ₂ O ₃ , Mo	W	Mo	Mo	Ta, Mo	Ta, Mo	Al ₂ O ₃	DC, RF	0.06@0.6	-	-	Evaporates well from any source.
Silver Bromide	AgBr	432	-	6.47	-	-	~380	-	-	Ta	-	-	-	-	Q	RF	2.28@0.58	-	-	-
Silver Chloride	AgCl	455	-	5.56	-	-	~520	-	-	Mo, Pt	-	-	Mo	Mo	Q	RF	2.13@0.43	-	-	-
Silver Iodide	AgI	558	-	6.01	-	-	~500	-	-	Ta	-	-	-	-	-	-	RF	2.02@0.59	-	-

Material	Symbol	Melting Point (°C)	S/D	Density g/cm ³ @20°C	Temp.(°C) for given Vap. Press. (mBar)			Evaporation Techniques						Index of Refraction (@µm)	Sputter	Comments	
					10 ⁻⁸	10 ⁻⁶	10 ⁻⁴	E-Beam			Thermal Sources						
								Suitability	Liner	Boat	Coil	Basket	Crucible				
Sodium	Na	98	-	0.97	74	124	192	-	-	-	Ta, SS	-	-	-	Q	Preheat gently to outgas. Metal reacts quickly in air.	
Sodium Bromide	NaBr	747	-	3.20	-	-	~400	-	-	-	-	-	-	-	Q	Preheat gently to outgas.	
Sodium Chloride	NaCl	801	-	2.17	-	-	530	F	-	-	Ta, W, Mo	-	-	-	Q	Copper oven. Little decomposition. Preheat gently to outgas. Hygroscopic.	
Sodium Cyanide	NaCN	564	-	-	-	-	~550	-	-	-	Ag	-	-	-	-	Toxic. Preheat gently to outgas.	
Sodium Fluoride	NaF	993	-	2.56	-	-	~1000	F	-	-	Mo, Ta, W	-	-	-	-	Preheat gently to outgas. No decomposition.	
Sodium Hydroxide	NaOH	318	-	2.13	-	-	~470	-	-	-	Pt	-	-	-	-	Preheat gently to outgas.	
Chiolote	Na ₂ Al ₃ F ₁₄	-	-	2.9	-	-	~800	-	-	-	Mo, W	-	-	-	-	-	
Cryolite	Na ₃ AlF ₆	1000	-	2.9	1020	1260	1480	Ex	Gr, VC	W, Mo, Ta	-	-	W, Mo, Ta	VC	VC	Large chunks reduce spitting. Little decomposition.	
Strontium	Sr	769	-	2.6	239	309	403	F	VC	W, Ta, Mo	W	W	W	VC	VC	Toxic. Wets but does not alloy with refractory metals. May react in air.	
Strontium Chloride	SrCl ₂	875	-	3.05	-	-	-	-	-	-	-	-	-	-	-	-	
Strontium Fluoride	SrF ₂	1473	-	4.24	-	-	~1000	-	-	-	-	-	-	Al ₂ O ₃	RF	1.44@0.59	
Strontium Oxide	SrO	2430	S	4.7	-	-	1500	-	-	Mo	-	-	-	Al ₂ O ₃	RF	1.88@0.58	
Strontium Sulfide	SrS	>2000	D	3.70	-	-	-	-	-	Mo	-	-	-	-	RF	2.11@0.59	Reacts with molybdenum and tungsten.

Material	Symbol	Melting Point (°C)	S/D	Density g/cm ³ @20°C	Temp.(°C) for given Vap. Press. (mBar)						Evaporation Techniques						Sputter	Index of Refraction (@µm)	Comments
					10 ³		10 ⁵		10 ⁻⁴		E-Beam			Thermal Sources					
					10 ³	10 ⁵	10 ³	10 ⁵	10 ³	10 ⁵	10 ⁻⁴	Suitability	Liner	Boat	Coil	Basket			
Sulfur	S	113	-	2.07	13	19	57	P	-	W	-	W	Q	-	-	-	Toxic. Bad for vacuum systems.		
Tantalum	Ta	2996	-	16.6	1960	2240	2590	Ex	Gr	-	-	-	-	-	DC, RF	2.05@0.58	Forms good films. Traps O ₂ . Sputtering preferred.		
Tantalum Boride	TaB ₂	3000	-	11.15	-	-	-	-	-	-	-	-	-	-	RF, DC	-	-		
Tantalum Carbide	TaC	3880	-	13.9	-	-	~2500	-	-	-	-	-	-	-	RF, DC	-	-		
Tantalum Nitride	TaN	3360	-	16.30	-	-	-	-	-	-	-	-	-	-	RF, RF-R, DC	-	Evaporates tantalum in 10 ⁻³ Torr nitrogen.		
Tantalum Pentoxide	Ta ₂ O ₅	1872	-	8.2	1550	1780	1920	G	VC	Ta	W	W	VC	RF, RF-R	2.1@0.50	Slight decomposition. Evaporates in 10 ⁻³ Torr oxygen. Films with high dielectric constant.			
Tantalum Sulfide	TaS ₂	>1300	-	-	-	-	-	-	-	-	-	-	-	RF	-	-	-		
Technetium	Tc	2200	-	11.5	1570	1800	2090	-	-	-	-	-	-	-	-	-	-		
Teflon	PTFE	330	-	2.9	-	-	-	-	-	W	-	-	-	RF	-	Baffled source. Film structure doubtful.			
Tellurium	Te	452	-	6.25	157	207	277	P	Gr, VC, Al ₂ O ₃	W	W	W, Ta	Al ₂ O ₃ , Q	RF	4.7@0.55	Toxic. Wets refractory metals without alloying.			

Material	Symbol	Melting Point (°C)	S/D	Density g/cm ³ @20°C	Temp.(°C) for given Vap. Press. (mBar)			Evaporation Techniques					Sputter	Index of Refraction (@µm)	Comments		
					10 ⁻⁸	10 ⁻⁶	10 ⁻⁴	E-Beam		Thermal Sources							
								Suitability	Liner	Boat	Coil	Basket				Crucible	
Terbium	Tb	1356	-	8.23	800	950	1150	EX	Al ₂ O ₃	Ta	-	-	-	Al ₂ O ₃	RF	-	-
	TbF ₃	1172	-	-	-	-	~800	-	-	-	-	-	-	-	RF	-	-
Thallium	Tl	304	-	11.85	280	360	470	P	Gr	W, Ta	-	-	W	Q, Al ₂ O ₃	DC	-	Very toxic. Wets freely.
	TlBr	480	S	7.56	-	-	250	-	-	Ta	-	-	-	Q,	RF	2.65@0.44 / 2.32@24	Toxic.
	TlCl	430	S	7	-	-	150	-	-	Ta	-	-	-	Q,	RF	2.20@0.75 / 2.56@12	-
	TlI	440	S	7.1	-	-	250	P	-	-	-	-	-	Q,	RF	-	-
	Tl ₂ O ₃	717	-	9.65	-	-	350	P	-	Mo	-	-	-	-	RF	-	Toxic. Disproportionates at 850°C to Tl ₂ O
Thorium	Th	1875	S	11.7	1430	1660	1925	EX	-	W, Ta, Mo	W	W	W	-	-	-	Toxic, radioactive. Wets W.
	ThBr ₄	610	S	5.67	-	-	-	-	-	Mo	-	-	-	-	-	2.47	Radioactive. Toxic.
	ThC ₂	2655	-	8.96	-	-	~2300	-	-	-	-	-	-	C	RF, DC	-	Radioactive.
	ThF ₄	>900	-	6.32	-	-	~750	F	VC	Ni	-	-	W	VC	RF	1.52@0.5	Radioactive. Heat substrate to above 150°C.
	ThO ₂	3220	-	9.86	-	-	~2100	G	-	W	-	-	-	-	RF, RF-R	1.8@0.55	Radioactive.
Thorium Oxide	ThO ₂	900	-	9.1	-	-	-	-	-	Mo, Ta	-	-	-	-	-	1.52	Radioactive. Films often ThF ₄ .
	ThS ₂	1925	-	7.30	-	-	-	-	-	-	-	-	-	RF	-	-	Radioactive. Sputtering preferred or co-evaporate from two sources.
Thulium	Tm	1545	S	9.32	461	554	680	G	Al ₂ O ₃	Ta	-	-	-	Al ₂ O ₃	DC	-	-
	Tm ₂ O ₃	-	D	8.90	-	-	1500	-	-	Ir	-	-	-	-	RF	-	-

Material	Symbol	Melting Point (°C)	S/D	Density g/cm ³ @20°C	Temp.(°C) for given Vap. Press. (mBar)			Evaporation Techniques						Index of Refraction (@µm)	Comments	
					10 ⁸	10 ⁶	10 ⁻⁴	E-Beam		Thermal Sources			Sputter			
								Suitability	Liner	Boat	Coil	Basket				Crucible
Tin	Sn	232	-	7.28	682	807	997	Ex	Gr, Al ₂ O ₃	Mo	W	W	Al ₂ O ₃	DC, RF	1.48@0.59	wets molybdenum.
Tin Oxide	SnO ₂	1630	S	6.95	-	-	~1000	Ex	Al ₂ O ₃	W	W	W	Q, Al ₂ O ₃	RF, RF-R	2.08@0.58	Films from tungsten are oxygen deficient, oxidize in air.
Tin Selenide	SnSe	861	-	6.18	-	-	~400	F	-	-	-	-	Q	RF	-	-
Tin Sulfide	SnS	882	-	5.22	-	-	~450	-	-	-	-	-	Q	RF	-	-
Tin Telluride	SnTe	780	D	6.48	-	-	~450	-	-	-	-	-	Q	RF	-	-
Titanium	Ti	1660	-	4.5	1067	1235	1453	Ex	Gr	Ta	-	-	TiC, VC	DC, RF	2.64@0.58	Alloys with refractory metals; evolves gas on first heating.
Titanium Boride	TiB ₂	2900	-	4.50	-	-	-	P	-	-	-	-	-	RF, DC	-	-
Titanium Carbide	TiC	3140	-	4.93	-	-	~2300	-	-	-	-	-	-	RF, DC	-	-
Titanium Nitride	TiN	2930	-	5.22	-	-	-	G	-	Mo	-	-	-	RF, RF-R, DC	-	Sputtering preferred. Decomposes with thermal evaporation.
Titanium (II) Oxide	TiO	1750	-	4.93	-	-	~1500	G	Gr, VC	W, Ta	-	-	VC	RF	2.4@0.55	Film TiO ₂ if evaporated like TiO ₂ . Preheat gently to outgas.
Titanium (III) Oxide	Ti ₂ O ₃	2130	D	4.6	-	-	-	G	-	W	-	-	-	RF	2.3@0.5	-
Titanium (IV) Oxide	TiO ₂	1830	-	4.26	-	-	~1300	F	Mo	W	-	W	-	RF, RF-R	2.3@0.5	Suboxide, must be reoxidized to rutile. Tantalum reduces TiO ₂ to TiO and titanium.

Material	Symbol	Melting Point (°C)	S/D	Density g/cm ³ @20°C	Temp.(°C) for given Vap. Press. (mBar)			Evaporation Techniques						Sputter	Index of Refraction (@µm)	Comments
					10 ⁻⁸	10 ⁻⁶	10 ⁻⁴	E-Beam			Thermal Sources					
								Suitability	Liner	Boat	Coil	Basket	Crucible			
Tungsten	W	3410	-	19.35	2117	2407	2757	G	-	-	-	-	-	RF, DC	2.76@0.58	Forms volatile oxides. Films hard and adherent.
Tungsten Boride	WB ₂	~2900	-	10.77	-	-	-	P	-	-	-	-	-	RF	-	-
Tungsten Carbide	WC	2860	-	15.8	1480	1720	2120	-	-	-	-	-	-	RF, DC	-	-
Tungsten Carbide	W ₂ C	2860	-	17.15	1480	1720	2120	Ex	-	C	-	-	-	RF, DC	-	-
Tungsten Disulfide	WS ₂	1250	D	7.5	-	-	-	-	-	-	-	-	-	RF	-	-
Tungsten Oxide	WO ₃	1473	S	7.16	-	-	980	G	-	W, Pt	-	-	-	RF-R	1.7@0.55	Preheat gently to outgas. Tungsten reduces oxide slightly.
Tungsten Selenide	WSe ₂	-	-	9.0	-	-	-	-	-	-	-	-	-	RF	-	-
Tungsten Silicide	WSi ₂	>900	-	9.4	-	-	-	-	-	-	-	-	-	RF, DC	-	-
Tungsten Telluride	WTe ₃	-	-	9.49	-	-	-	-	-	-	-	-	-	RF	-	-
Uranium	U	1132	-	19.05	1132	1327	1582	G	-	Mo, W	W	W	W	-	-	Forms oxidize. Radioactive.
Uranium Carbide	UC ₂	2350	D	11.28	-	-	2100	-	-	-	-	-	C	RF	-	-
Uranium Fluoride	UF ₄	960	-	6.70	-	-	300	-	-	Ni	-	-	-	RF	-	-
Uranium (III) Oxide	U ₂ O ₃	1300	D	8.30	-	-	-	-	-	W	-	W	-	RF-R	-	Disproportionates at 1300°C to UO ₂ .
Uranium (IV) Oxide	UO ₂	2878	-	10.96	-	-	-	-	-	W	-	W	-	RF	-	Tantalum causes decomposition.
Uranium Phosphide	UP ₂	-	D	8.57	-	-	1200	-	-	Ta	-	-	-	RF	-	-
Uranium (II) Sulfide	US	>2000	-	10.87	-	-	-	-	-	-	-	-	-	-	-	-
Uranium (IV) Sulfide	US ₂	>1100	-	7.96	-	-	-	-	-	W	-	-	-	RF	-	Slight decomposition.

Material	Symbol	Melting Point (°C)	S/D	Density g/cm ³ @20°C	Temp.(°C) for given Vap. Press. (mBar)			Evaporation Techniques					Sputter	Index of Refraction (@µm)	Comments
					10 ⁸	10 ⁶	10 ⁻⁴	E-Beam		Thermal Sources					
								Suitability	Liner	Boat	Coil	Basket			
Vanadium	V	1890	-	5.96	1162	1332	1547	Ex	-	Mo	-	-	DC, RF	3.03@0.58	Wets molybdenum. E-beam-evaporated films preferred. Alloy slightly with W.
Vanadium Boride	VB ₂	2400	-	5.10	-	-	-	-	-	-	-	-	RF, DC	-	-
Vanadium Carbide	VC	2810	-	5.77	-	-	~1800	-	-	-	-	-	RF, DC	-	-
Vanadium Nitride	VN	2320	-	6.13	-	-	-	-	-	-	-	-	RF, RF-R, DC	-	-
Vanadium (IV) Oxide	VO ₂	1967	S	4.34	-	-	~575	-	-	-	-	-	RF, RF-R	2.51@0.63	Sputtering preferred.
Vanadium (V) Oxide	V ₂ O ₅	690	-	3.36	-	-	~500	-	-	-	Q	-	RF	-	-
Vanadium Silicide	VSi ₂	1700	-	4.42	-	-	-	-	-	-	-	-	RF	-	-
Ytterbium	Yb	819	-	6.96	247	317	417	G	-	Ta	-	-	DC, RF	-	-
Ytterbium Fluoride	YbF ₃	1157	-	-	-	-	~800	-	-	Mo	-	-	RF	1.5@0.55	-
Ytterbium Oxide	Yb ₂ O ₃	2346	S	9.17	-	-	~1500	-	-	Ir	-	-	RF, RF-R	1.9@0.55	Loses oxygen.
Yttrium	Y	1522	-	4.47	830	973	1157	Ex	-	W, Ta	W	-	RF, DC	-	High tantalum solubility.
Yttrium Aluminum Oxide	Y ₃ Al ₅ O ₁₂	1990	-	-	-	-	-	G	-	-	W	-	RF	-	Films not ferroelectric.
Yttrium Fluoride	YF ₃	1387	-	4.01	-	-	-	-	-	-	-	-	RF	1.5@0.55	-
Yttrium Oxide	Y ₂ O ₃	2410	-	5.01	-	-	~2000	G	-	W	-	-	RF, RF-R	1.79@0.589	Loses oxygen, films smooth and clear.

Material	Symbol	Melting Point (°C)	S/D	Density g/cm ³ @20°C	Temp.(°C) for given Vap. Press. (mBar)			Evaporation Techniques						Sputter	Index of Refraction (@µm)	Comments
					10 ⁸	10 ⁶	10 ⁴	E-Beam			Thermal Sources					
								Suitability	Liner	Boat	Coil	Basket	Crucible			
Zinc	Zn	420	-	7.14	127	177	250	Ex	Al ₂ O ₃	Mo, W, Ta	W	W	Al ₂ O ₃ , Q	DC, RF	1.93@0.589	Evaporates well under wide range of conditions. Bad for vacuum systems. Wets refractory metals.
Zinc Antimonide	Zn ₃ Sb ₂	570	-	6.33	-	-	-	-	-	-	-	-	-	RF	-	-
Zinc Bromide	ZnBr ₂	394	D	4.20	-	-	~300	-	W	-	-	-	C	RF	1.58@0.58	-
Zinc Fluoride	ZnF ₂	872	-	4.95	-	-	~800	-	-	Pt, Ta	-	-	Q	RF	-	-
Zinc Nitride	Zn ₃ N ₂	-	D	6.22	-	-	-	-	-	Mo	-	-	-	RF	-	-
Zinc Oxide	ZnO	1975	-	5.61	-	-	~1800	F	-	-	-	-	-	RF-R	2@0.55	Anneal in air at 450°C to re oxidize.
Zinc Selenide	ZnSe	>1100	-	5.42	-	-	660	-	-	Ta, W, Mo	W, Mo	W	Q	RF	2.6@0.55	Toxic. Preheat gently to outgas. Evaporates well.
Zinc Sulfide	ZnS	1700	S	3.98	-	-	~800	G	-	Ta, Mo	-	-	Q	RF	2.3@0.55	Preheat gently to outgas. Films partially decompose. Sticking coefficient varies with substrate temperature.
Zinc Telluride	ZnTe	1239	-	6.34	-	-	~600	-	-	Mo, Ta	-	-	-	RF	3.56@0.59	Toxic. Preheat gently to outgas.
Zirconium	Zr	1852	-	6.49	1477	1702	1987	Ex	Mo	W	-	-	-	RF, DC	-	Flammable. Alloys with tungsten. Films oxidize readily.
Zirconium Boride	ZrB ₂	~3200	-	6.09	-	-	-	G	-	-	-	-	-	RF, DC	-	-
Zirconium Carbide	ZrC	3540	-	6.73	-	-	~2500	-	-	-	-	-	-	RF, DC	-	-
Zirconium Nitride	ZrN	2980	-	7.09	-	-	-	-	-	-	-	-	-	RF, RF-R, DC	-	Reactively evaporates in 10 ⁻³ Torr nitrogen.
Zirconium Oxide	ZrO ₂	~2700	-	5.89	-	-	~2200	G	Mo	W	-	-	-	RF, RF-R	2.05@0.5	Films oxygen deficient, clear and hard.
Zirconium Silicate	ZrSiO ₄	2550	-	4.56	-	-	-	-	-	-	-	-	-	RF	1.96@0.59	-
Zirconium Silicide	ZrSi ₂	1700	-	4.88	-	-	-	-	-	-	-	-	-	RF, DC	-	-

Vapor Pressures Table

**Table of temperatures (°C)
at which vapor pressures (mbar) are:**

Element	10 ⁻¹¹	10 ⁻¹⁰	10 ⁻⁹	10 ⁻⁸	10 ⁻⁷	10 ⁻⁶	10 ⁻⁵	10 ⁻⁴	10 ⁻³	10 ⁻²	10 ⁻¹	1	10 ¹	10 ²	10 ³
Actinium	772	827	887	957	1032	1117	1217	1332	1467	1632	1827	2077	2387	2757	3237
Silver	448	486	527	574	626	685	752	832	922	1027	1162	1332	1542	1827	2217
Aluminum	542	587	633	685	742	812	887	972	1082	1217	1367	1557	1777	2097	2527
Americium	439	479	524	575	632	698	777	867	972	1102	1267	1472	1747	2127	2697
Arsenic	50	67	85	104	127	150	174	204	237	277	317	372	439	522	627
Astatine	-52	-42	-32	-21	-8	7	23	43	65	91	125	161	207	267	347
Gold	642	691	747	807	877	947	1032	1132	1252	1397	1567	1767	2047	2407	2857
Boron	1062	1132	1207	1282	1367	1467	1582	1707	1867	2027	2247	2507	2827	3227	3727
Barium	177	207	237	272	310	354	402	462	527	610	711	852	1037	1297	1657
Beryllium	559	605	652	707	762	832	907	997	1097	1227	1377	1557	1807	2117	2537
Bismuth	237	267	295	329	367	409	459	517	587	672	777	897	1077	1297	1627
Carbone	1422	1492	1572	1657	1757	1867	1987	2137	2287	2457	2657	2897	3177	3507	3917
Calcium	197	222	251	282	317	357	405	459	522	597	689	802	977	1202	1527
Cadmium	20	37	55	74	95	119	146	177	217	265	320	392	489	612	787
Cerium	777	837	902	972	1052	1147	1252	1377	1522	1697	1907	2167	2507	2947	3557
Cobalt	747	797	857	922	992	1067	1157	1257	1382	1517	1687	1907	2167	2517	2947
Chromium	687	737	782	837	902	977	1062	1157	1267	1397	1552	1737	1967	2277	2727
Cesium	-60	-47	-32	-16	1	24	49	78	114	155	209	280	370	502	707
Copper	582	622	672	722	787	852	937	1027	1132	1257	1417	1617	1867	2187	2647
Dysprosium	487	528	574	625	682	747	817	897	997	1117	1262	1437	1692	2027	2507
Erbium	506	549	596	649	708	777	852	947	1052	1177	1332	1527	1787	2147	2647
Europium	196	222	250	283	319	361	409	466	532	611	708	827	987	1227	1527
Francium	-75	-63	-48	-31	-13	7	33	61	95	137	189	255	347	487	707
Iron	727	777	832	892	957	1032	1127	1227	1342	1477	1647	1857	2117	2467	2927
Gallium	482	523	568	619	677	742	817	907	1007	1132	1282	1472	1707	2027	2457
Gadolinium	607	657	707	762	827	897	977	1077	1192	1327	1487	1682	1947	2307	2827
Germanium	667	707	757	812	877	947	1037	1137	1257	1397	1557	1777	2047	2407	2907
Hafnium	1232	1307	1392	1487	1592	1707	1847	1997	2177	2397	2657	2967	3357	3857	4507

Element	10 ⁻¹¹	10 ⁻¹⁰	10 ⁻⁹	10 ⁻⁸	10 ⁻⁷	10 ⁻⁶	10 ⁻⁵	10 ⁻⁴	10 ⁻³	10 ⁻²	10 ⁻¹	1	10 ¹	10 ²	10 ³
Mercury	-103	-93	-83	-72	-59	-44	-27	-7	16	46	80	125	185	262	369
Holmium	506	549	596	649	708	777	852	947	1052	1177	1332	1527	1787	2137	2637
Indium	368	404	443	488	539	597	664	742	837	947	1082	1247	1467	1757	2157
Iridium	1312	1392	1482	1577	1687	1807	1947	2107	2287	2497	2767	3087	3477	3977	4627
Potassium	-26	-13	3	21	42	65	91	123	161	208	267	345	447	585	797
Lanthanum	827	882	947	1022	1102	1192	1297	1422	1562	1727	1927	2177	2487	2877	3407
Lithium	157	179	207	235	268	306	350	404	467	537	627	747	897	1097	1347
Lutetium	727	787	847	912	987	1072	1167	1277	1412	1572	1757	1997	2277	2637	3097
Magnesium	115	137	159	185	214	246	282	327	377	439	509	605	727	897	1127
Manganese	387	422	461	505	554	611	675	747	837	937	1062	1217	1422	1697	2097
Molybdenum	1337	1417	1497	1592	1702	1822	1957	2117	2307	2527	2787	3117	3517	4027	4747
Sodium	21	37	55	74	97	123	155	93	235	289	357	441	552	705	902
Niobium	1492	1572	1662	1762	1867	1987	2127	2277	2447	2657	2897	3177	3517	3927	4437
Neodymium	573	622	672	727	797	862	947	1047	1167	1302	1497	1727	2027	2467	3157
Nickel	767	817	872	927	997	1072	1157	1262	1382	1527	1697	1907	2157	2497	2957
Osmium	1602	1692	1787	1897	2017	2157	2307	2487	2687	2917	3187	3527	3927	4437	5067
Phosphore	10	24	39	54	69	88	108	129	157	185	220	261	309	369	442
Lead	243	273	307	342	383	429	485	547	625	715	832	977	1162	1427	1797
Palladium	672	722	777	842	912	992	1082	1192	1317	1462	1647	1877	2177	2567	3107
Polonium	59	75	92	111	135	159	187	221	264	315	382	470	589	767	977
Praseodymium	627	677	732	797	867	947	1042	1147	1277	1427	1617	1847	2147	2547	3097
Platinum	1062	1132	1207	1292	1382	1492	1612	1747	1907	2097	2317	2587	2917	3337	3897
Plutonium	658	710	767	832	907	992	1092	1207	1342	1507	1702	1957	2277	2707	3317
Radium	163	187	215	247	279	317	365	417	482	557	647	787	952	1217	1567
Rubidium	-46	-33	-19	-2	16	39	63	94	129	173	227	295	392	529	727
Rhenium	1627	1722	1827	1947	2077	2217	2387	2587	2807	3067	3407	3807	4327	4947	5777
Rhodium	1057	1122	1197	1277	1367	1472	1582	1707	1857	2037	2247	2507	2837	3247	3797
Ruthenium	1267	1337	1422	1507	1607	1717	1847	1987	2147	2347	2587	2857	3207	3627	4177
Sulfur	-43	-33	-21	-10	3	17	37	55	80	109	147	189	246	333	466
Antimony	204	225	253	279	309	345	383	425	475	533	612	757	977	1287	1687
Scandium	608	656	710	772	837	917	1007	1107	1232	1377	1562	1797	2097	2507	3087
Selenium	13	28	44	63	83	107	133	164	199	243	297	363	446	553	699
Silicon	817	872	927	992	1067	1147	1237	1337	1472	1632	1817	2057	2347	2717	3217
Samarium	269	300	335	371	415	465	517	580	653	742	847	987	1177	1442	1847
Tin	532	579	627	682	747	807	897	997	1107	1247	1412	1612	1867	2227	2687
Strontium	160	185	210	241	273	309	353	404	465	537	627	732	887	1097	1407
Tantalum	1657	1747	1847	1957	2097	2237	2407	2587	2807	3057	3357	3707	4127	4657	5307
Terbium	627	677	732	797	867	947	1042	1147	1277	1427	1617	1847	2147	2547	3097
Technetium	1307	1392	1477	1567	1677	1787	1927	2077	2257	2487	2757	3097	3517	4027	4727
Tellurium	93	112	132	155	181	209	242	280	323	374	433	518	632	792	1027
Thorium	1177	1252	1337	1432	1542	1662	1807	1977	2167	2407	2687	3037	3477	4067	4857
Titanium	867	927	992	1062	1137	1227	1327	1442	1577	1737	1937	2177	2487	2857	3367
Thallium	200	226	254	283	319	359	407	463	530	609	706	827	982	1187	1477
Thulium	351	382	418	458	503	552	609	680	757	847	962	1097	1267	1487	1787
Uranium	917	982	1052	1132	1222	1327	1447	1582	1737	1927	2157	2447	2807	3267	3907
Vanadium	962	1022	1092	1162	1237	1332	1432	1547	1687	1847	2047	2287	2577	2947	3447
Tungstene	1777	1877	1997	2117	2247	2407	2567	2757	2977	3227	3537	3907	4357	4927	5627
Yttrium	772	827	887	957	1032	1117	1217	1332	1467	1632	1832	2082	2397	2812	3377
Ytterbium	163	187	215	247	279	317	365	417	482	557	647	787	952	1217	1567
Zinc	63	81	101	123	148	177	209	247	292	344	408	487	597	737	937
Zirconium	1227	1307	1392	1482	1582	1702	1837	1987	2177	2397	2657	2977	3377	3897	4557



neyco

30 avenue de la Paix
92170 Vanves - France
Tel: +33(0)1 41 90 50 50
Fax: +33(0)1 41 90 50 51

www.neyco.fr



Materials A 2018-1

neyco



B

MATERIALS POWDERS

- Particle Size Conversion Table B 03
- High Purity Inorganic Powders B 04
- Nanopowders B 38
- Thermal Spray Powders B 44

PURITY

Purity is based on spectrographic values of trace metals found, i. e. 99.999% pure indicates that 0.001% (10 ppm) total of trace metals have been observed. 99.9% pure implies a total metallic impurity content of 0.1% (1000 ppm). Gases, Carbon and Sulfur are not included in the analysis but can possibly be determined if needed.

PARTICLE SIZES

Particle sizes are listed as determined with sieves. “-100, +325 mesh” means that all of the particles pass through a 100 mesh screen and are completely retained on a 325 mesh screen. “Mesh” indicates the number of sieve openings per linear inch.



CERTIFICATE OF ANALYSIS AND MSDS

All items are shipped with an analysis certificate. The analysis is specific to the actual lot of material being sent and not a “typical analysis”, unless specifically stated.

All dangerous materials are shipped attached by a Material Safety Data Sheet (MSDS).

CUSTOM MANUFACTURING

The particle sizes and purity listed are those most commonly used and called as. However Neyco can offer nearly any range of particle sizes desired, with purity needed on request.

Whether you require a product with only a minor variation from our standard material, a complete custom chemical synthesis, or a custom metal fabrication, Neyco is your source.

Particle Size Conversion Table

MESH SIZE	APPROXIMATE SIZE (μm)	APPROXIMATE SIZE (mm)
4	4760	4.760
6	3360	3.360
8	2380	2.380
10	2000	2.000
12	1680	1.680
14	1141	1.410
16	1190	1.190
18	1000	1.000
20	841	0.841
25	707	0.707
30	595	0.595
35	500	0.500
40	420	0.420
45	354	0.354
50	297	0.297
60	250	0.250
70	210	0.210
80	177	0.170
100	149	0.140
120	125	0.125
140	105	0.100
170	88	0.088
200	74	0.074
230	63	0.063
270	53	0.053
325	44	0.044
400	37	0.037
425	35	0.035
625	20	0.020
1250	10	0.010
2500	5	0.005

High Purity Inorganic Powders

AI 13 ALUMINUM Base

CHEMICAL	FORMULA	DESCRIPTION	PURITY*
Aluminum	Al	-200 mesh to 1 μm aver. or less	99 to 99.99
Aluminum Arsenide	AlAs	-20 mesh to -325 mesh	99.5
Aluminum Boride	AlB ₂	-200 mesh	99 to 99.5
Aluminum Bromide	AlBr ₃	-10 mesh	99.999
Aluminum Carbide	Al ₄ C ₃	-325 mesh	99 to 99.9
Aluminum Chloride	AlCl ₃	-10 mesh to -100 mesh	99.9 to 99.999
Aluminum Fluoride	AlF ₃	-100 mesh	99.9 to 99.99
Aluminum Hydroxide	Al(OH) ₃	-100 mesh	99.9
Aluminum Iodide	AlI ₃	-10 mesh to -100 mesh	99.998
Aluminum Molybdate	Al ₂ (MoO ₄) ₃	-100 mesh	99.5 to 99.9
Aluminum Nickelide	AlNi	-10 mesh to -100 mesh	99.9 to 99.999
Aluminum Nitride	AlN	-100 mesh to -400 mesh	99.5 to 99.9
Aluminum Oxide	Al ₂ O ₃	-40 mesh to 1 μm aver. or less	99.2 to 99.999
Aluminum Oxide Chromium Oxide (98/2 wt%)	Al ₂ O ₃ -Cr ₂ O ₃	-325 mesh, +10 μm	99
Aluminum Oxide Silicon Oxide	3Al ₂ O ₃ -2SiO ₂	-140, +325 mesh to -325 mesh	98
Aluminum Telluride	Al ₂ Te ₃	-160 mesh	99.999
Aluminum Oxide Titanium Oxide (97/3 wt%)	Al ₂ O ₃ -TiO ₂	-325 mesh, +10 μm	99
Aluminum Silicon (88/12 wt%)	Al-Si	-170, +325 mesh to -325 mesh	99
Aluminum Sulfide	Al ₂ S ₃	-100 mesh	99.9
Aluminum Silicon Copper	AlSiCu	-300 mesh	99.99

*Purity based on metallic impurities.

CHEMICAL	FORMULA	DESCRIPTION	PURITY*
Aluminum Titanate	Al_2TiO_5	-100 mesh to -400 mesh	99.5
Aluminum Tungstate	$Al_2(WO_4)_3$	-100 mesh	99.9
Aluminum Zirconate	$Al_2O_3 \cdot 3ZrO_2$	-100 mesh	99

Sb

51

ANTIMONY Base

CHEMICAL	FORMULA	DESCRIPTION	PURITY*
Antimony	Sb	-100, +325 mesh to -325 mesh	99.5 to 99.995
Antimony Bromide	$SbBr_3$	-8 mesh to -100 mesh	99.5 to 99.999
Antimony Chloride	$SbCl_3$	-8 mesh to -100 mesh	99.999
Antimony Fluoride	SbF_3	-40 mesh	99.5
Antimony Iodide	SbI_3	-80 mesh to -100 mesh	99.999
Antimony Oxide	Sb_2O_3	-100 mesh to -425 mesh	99.9 to 99.999
Antimony Selenide	Sb_2Se_3	-325 mesh	99 to 99.999
Antimony Sulfide	Sb_2S_3	-325 mesh	99.9 to 99.995
Antimony Sulfoiodide	SbSI	-20 mesh	99.9
Antimony Telluride	SbTe	-100 mesh	99.999
Antimony Telluride	Sb_2Te_3	-100 mesh to -325 mesh	99 to 99.999

As

33

ARSENIC Base

CHEMICAL	FORMULA	DESCRIPTION	PURITY*
Arsenic	As	-20 mesh to 325 mesh	99 to 99.999
Arsenic Iodide	AsI_3	-80 mesh	99
Arsenic Oxide	As_2O_5	-100 mesh	99.9
Arsenic Selenide	As_2Se_3	-160 mesh to -325 mesh	99.999
Arsenic Sulfide	As_2S_3	-160 mesh	99.999
Arsenic Telluride	As_2Te_3	-160 to -325 mesh	99 to 99.999

*Purity based on metallic impurities.

Ba

56

BARIUM Base

CHEMICAL	FORMULA	DESCRIPTION	PURITY*
Barium Aluminate	BaAl ₂ O ₄	-100 mesh	99.5 to 99.9
Barium Boride	BaB ₆	-100 mesh to +325 mesh	99.5 to 99.9
Barium Bromide	BaBr ₂	-20 mesh to -100 mesh	99.9 to 99.998
Barium Carbide	BaC ₂	-8 mesh	99.5
Barium Carbonate	BaCO ₃	-20 mesh to -400 mesh	99.9 to 99.9999
Barium Chlorate	Ba(ClO ₃) ₂	-80 mesh	99.9
Barium Chromate	BaCrO ₄	-100 mesh	99.5
Barium Copper Oxide	BaCuO ₂	-100 mesh	99.9
Barium Ferrite	BaFe ₁₂ O ₁₉	-325 mesh	98
Barium Fluoride	BaF ₂	-40 mesh to -325 mesh	99.95 to 99.995
Barium Hydride	BaH ₂	-60 mesh	99.7
Barium Iodate	Ba(IO ₃) ₂	-80 mesh	99.5
Barium Iodide	BaI ₂	-10 mesh to -80 mesh	99.955 to 99.999
Barium Molybdate	BaMoO ₄	-100 mesh	99.9
Barium Niobium Oxide	BaNb ₂ O ₆	-60 mesh	99.9
Barium Nitride	Ba ₃ N ₂	-20 mesh	99.7
Barium Oxide	BaO	-100 mesh	99.5
Barium Peroxide	BaO ₂	-80 mesh	99
Barium Selenide	BaSe	-20 mesh	99.5
Barium Stannate	BaSnO ₃	-325 mesh	99
Barium Sulfate	BaSO ₄	-100 mesh	99 to 99.995
Barium Sulfide	BaS	-200 mesh	99.9
Barium Tantalate	BaTa ₂ O ₆	-100 mesh	99
Barium Telluride	BaTe	-20 mesh	99.5
Barium Titanate	BaTiO ₃	-325 mesh to ~ 5 μm	99 to 99.95
Barium Tungstate	BaWO ₄	-200 mesh	99.9
Barium Vanadate	Ba ₃ (VO ₄) ₂	-200 mesh	99.9
Barium Zirconate	BaZrO ₃	-100, +200 mesh to -325 mesh	99
Barium Zirconate Titanate	BaTiZrO ₅	-100 mesh	99.9

*Purity based on metallic impurities.

Bi

83

BISMUTH Base

CHEMICAL	FORMULA	DESCRIPTION	PURITY*
Bismuth	Bi	-100, +325 mesh to -200 mesh	99.5 to 99.999
Bismuth Bromide	BiBr ₃	-60 mesh	99 to 99.999
Bismuth Chloride	BiCl ₃	-60 mesh	99.9 to 99.999
Bismuth Chromate	Bi ₂ Cr ₂ O ₉	-100 mesh	99.9
Bismuth Fluoride	BiF ₃	-60 mesh to -200 mesh	99.9 to 99.999
Bismuth Iodide	BiI ₃	-40 mesh to -100 mesh	99.9 to 99.999
Bismuth Molybdate	Bi ₂ MoO ₆	-325 mesh	99
Bismuth Molybdate	Bi ₂ Mo ₃ O ₁₂	-200 mesh	99.5
Bismuth Oxide	Bi ₂ O ₃	-300 mesh to -325 mesh	99.9 to 99.999
Bismuth Oxide	Bi ₂ O ₄ · 2H ₂ O	-200 mesh	99.8
Bismuth Selenide	Bi ₂ Se ₃	-200 mesh to -325 mesh	99 to 99.999
Bismuth Stannate	Bi ₂ Sn ₂ O ₇	-200 mesh	99.9
Bismuth Sulfide	Bi ₂ S ₃	-160 mesh	99.999
Bismuth Telluride	Bi ₂ Te ₃	-160 mesh to -325 mesh	99.99 to 99.999
Bismuth Telluride Selenide	Bi _{0.5} Te _{2.7} Se _{0.3}	-160 mesh	99.99
Bismuth Titanate	Bi ₂ TiO ₃	-100 mesh	99.9
Bismuth Titanate	Bi ₄ Ti ₃ O ₁₂	-325 mesh	99.9
Bismuth Titanate	Bi ₂ Ti ₄ O ₁₁	-325 mesh to -625 mesh	99.9
Bismuth Titanate	Bi ₁₂ TiO ₂₀	-325 mesh	99.9
Bismuth Tungstate	Bi ₂ O ₃ · 3WO ₃	-100 mesh to -200 mesh	99.9
Bismuth Vanadate	BiVO ₄	-200 mesh	99.9
Bismuth Zirconate	2Bi ₂ O ₃ · 3ZrO ₂	-325 mesh	99

B

5

BORON Base

CHEMICAL	FORMULA	DESCRIPTION	PURITY*
Boron	B	-200 mesh	99 to 99.8
Boron	B	-8, +20 mesh to 5 µm or less	90 to 99.999
Boron Carbide	B ₄ C	-60 mesh to 1 µm or less	99.5 to 99.8
Boron Nitride	BN	-40 mesh to 1 µm or less	97.5 to 99.5
Boron Oxide	B ₂ O ₃	-40 mesh to -200 mesh	99.9 to 99.99
Boron Silicide	B ₃ Si	-325 mesh	99.5
Boron Silicide	B ₄ Si	-200 mesh	98
Boron Silicide	B ₆ Si	-200 mesh	98

*Purity based on metallic impurities.

Cd
48

CADMIUM Base

CHEMICAL	FORMULA	DESCRIPTION	PURITY*
Cadmium	Cd	-200 mesh to -325 mesh	99.5 to 99.99
Cadmium Antimonide	CdSb	-325 mesh	99.999
Cadmium Arsenide	Cd ₃ As ₂	-325 mesh	99.999
Cadmium Carbonate	CdCO ₃	-200 mesh	99 to 99.999
Cadmium Chloride	CdCl ₂	-8 mesh to -10 mesh	99.9 to 99.995
Cadmium Fluoride	CdF ₂	-18 mesh to -100 mesh	99.9 to 99.99
Cadmium Iodide	CdI ₂	-40 mesh	99.5 to 99.998
Cadmium Molybdate	CdMoO ₄	-200 mesh	99.9
Cadmium Niobate	Cd ₂ Nb ₂ O ₇	-200 mesh	99.9
Cadmium Nitrate	Cd(NO ₃) ₂ ·4H ₂ O	-4 mesh	99.999
Cadmium Oxide	CdO	-200 mesh to -425 mesh	99.95 to 99.999
Cadmium Phosphide	Cd ₃ P ₂	-100 mesh	99.5
Cadmium Phosphide	CdP ₂	-100 mesh	99.9
Cadmium Selenide	CdSe	-40 mesh to -325 mesh	99.99 to 99.9955
Cadmium Selenite	CdSeO ₃	-80 mesh	99.5
Cadmium Stannate	Cd ₂ SnO ₄	-200 mesh	99.5
Cadmium Sulfide	CdS	-325 mesh to 10 μm aver. or less	99.5 to 99.999
Cadmium Tantalate	Cd ₂ Ta ₂ O ₇	-200 mesh	99.9
Cadmium Telluride	CdTe	-80 mesh to -325 mesh	99 to 99.999
Cadmium Tungstate	CdWO ₄	-325 mesh	99.95
Cadmium Vanadate	CdV ₂ O ₆	-200 mesh	99.9
Cadmium Zirconate	CdO·ZrO ₂	-200 mesh	99.5

Ca
20

CALCIUM Base

CHEMICAL	FORMULA	DESCRIPTION	PURITY*
Calcium	Ca	-6 mesh	99.5
Calcium Aluminum Oxide	CaAl ₂ O ₄	-200 mesh	99 to 99.5
Calcium Arsenate	Ca ₃ (AsO ₄) ₂	-80 mesh	99
Calcium Boride	CaB ₆	-100 mesh to -325 mesh	99.5
Calcium Bromide	CaBr ₂ ·xH ₂ O	-80 mesh	95
Calcium Carbonate	CaCO ₃	-100 mesh to -400 mesh	99 to 99.999
Calcium Chloride	CaCl ₂	-10 mesh	99.9
Calcium Copper Titanate, CCTO	CaCu ₃ Ti ₄ O ₁₂	-325 mesh	99.95

*Purity based on metallic impurities.

CHEMICAL	FORMULA	DESCRIPTION	PURITY*
Calcium Fluoride	CaF ₂	-325 mesh, +425 mesh	99 to 99.995
Calcium Iodide	CaI ₂	-20 mesh	99.5
Calcium Lanthanum Sulfide	CaLa ₂ S ₄	-200 mesh	99.9
Calcium Nitrate	Ca(NO ₃) ₂ ·4H ₂ O	-4 mesh	99.999
Calcium Nitride	Ca ₃ N ₂	-200 mesh	99
Calcium Oxide	CaO	-50 mesh to -425 mesh	99.5 to 99.99
Calcium Selenide	CaSe	-20 mesh	99.5
Calcium Silicate	Ca ₂ SiO ₄	-325 mesh	99
Calcium Silicate	CaSiO ₃	-200 mesh	99
Calcium Silicide	CaSi ₂	-325 mesh	99.5
Calcium Stannate	CaSnO ₃	-325 mesh	99
Calcium Sulfate	CaSO ₄	-10 mesh	99.99
Calcium Sulfide	CaS	-325 mesh	99 to 99.99
Calcium Titanate	CaTiO ₃	-80 mesh to -425 mesh	99 to 99.9
Calcium Tungstate	CaWO ₄	-325 mesh	99.9
Calcium Vanadate	CaV ₂ O ₆	-325 mesh	99.9
Calcium Zirconate	CaZrO ₃	-100 mesh to -325 mesh	99



CERIUM Base

CHEMICAL	FORMULA	DESCRIPTION	PURITY*
Cerium	Ce	-40 mesh	99.9
Cerium Boride	CeB ₆	-325 mesh	99.5
Cerium Bromide	CeBr ₃	-20 mesh	99.9
Cerium Chloride	CeCl ₃	-20 mesh	99.9
Cerium Fluoride	CeF ₃	-60 mesh to -325 mesh	99.9 to 99.998
Cerium Hydride	CeH ₂₋₃	-40 mesh	99.9
Cerium Iodide	CeI ₃	-20 mesh	99.9
Cerium Oxide	CeO ₂	-140, +325 mesh to -325 mesh, +10 μm	99.5 to 99.99
Cerium Silicide	CeSi ₂	-20 mesh	99.5
Cerium Stannate	CeO ₂ -SnO ₂	-325 mesh	99.9
Cerium Sulfide	Ce ₂ S ₃	-325 mesh	99.9
Cerium Titanate	CeO ₂ -TiO ₂	-325 mesh	99.9
Cerium Tungstate	Ce ₂ (WO ₄) ₃	-200 mesh	99.9
Cerium Vanadate	CeVO ₄	-200 mesh	99.9
Cerium Zirconate	CeO ₂ -ZrO ₂	-325 mesh	99.5

*Purity based on metallic impurities.

Cs
55**CESIUM Base**

CHEMICAL	FORMULA	DESCRIPTION	PURITY*
Cesium Acetate	CsC ₂ H ₃ O ₂	-4 mesh	99.9
Cesium Bromide	CsBr	-4 mesh	99.9 to 99.999
Cesium Carbonate	Cs ₂ CO ₃	-20 mesh	99.9 to 99.996
Cesium Chloride	CsCl	-100 mesh	99.99
Cesium Fluoride	CsF	-4 mesh	99.9
Cesium Hydroxide	CsOH·xH ₂ O	-4 mesh	99.9
Cesium Iodate	CsIO ₃	-4 mesh	99.9
Cesium Iodide	CsI	-20 mesh to -100 mesh	99.9 to 99.999
Cesium Molybdate	Cs ₂ MoO ₄	-200 mesh	99.9
Cesium Niobate	CsNbO ₃	-200 mesh	99.9
Cesium Nitrate	CsNO ₃	-4 mesh to -20 mesh	99.99 to 99.999
Cesium Perchlorate	CsClO ₄	-4 mesh	99.9
Cesium Sulfate	Cs ₂ SO ₄	-20 mesh to -100 mesh	99.9
Cesium Tantalate	CsTaO ₃	-200 mesh	99.9
Cesium Titanate	Cs ₂ TiO ₃	-200 mesh	99.9
Cesium Tungstate	Cs ₂ WO ₄	-200 mesh	99.9
Cesium Vanadate	CsVO ₃	-100 mesh	99.9
Cesium Zirconate	Cs ₂ ZrO ₃	-200 mesh	99.9

Cr
24**CHROMIUM Base**

CHEMICAL	FORMULA	DESCRIPTION	PURITY*
Chromium	Cr	-100 mesh to 10 µm aver. or less	99.2 to 99.99
Chromium Antimonide	CrSb	-100 mesh	99
Chromium Arsenide	Cr ₂ As	-60 mesh	99
Chromium Boride	CrB	-140, +325 mesh to -325 mesh	99.5
Chromium Boride	CrB ₂	-325 mesh	99.5
Chromium Boride	Cr ₂ B	-325 mesh to -400 mesh	99.5
Chromium Boride	Cr ₅ B ₃	-325 mesh	99.5
Chromium Carbide	Cr ₃ C ₂	-100, +325 mesh to -325 mesh	99 to 99.8
Chromium Carbide	Cr ₇ C ₃	-325 mesh	99.5
Chromium Carbide	Cr ₂₃ C ₆	-325 mesh	99.5
Chromium Chloride	CrCl ₂	-80 mesh to -100 mesh	99.9 to 99.99
Chromium Chloride	CrCl ₃	-325 mesh	99
Chromium Fluoride	CrF ₃	-80 mesh	99.5
Chromium Nitride	CrN	-325 mesh	99.5 to 99.8
Chromium Nitride	Cr ₂ N	-325 mesh to -425 mesh	99 to 99.5

*Purity based on metallic impurities.

CHEMICAL	FORMULA	DESCRIPTION	PURITY*
Chromium Oxide	Cr ₂ O ₃	-20 mesh to 5 µm aver. or less	99 to 99.98
Chromium Phosphide	CrP	-100 mesh	99.5
Chromium Selenide	CrSe	-325 mesh	99.5
Chromium Silicide	Cr ₃ Si	-140, +325 mesh to -325 mesh	99.5
Chromium Silicide	CrSi ₂	-200, +325 mesh to -400 mesh	99.5 to 99.9
Chromium Silicide	Cr ₅ Si ₃	-325 mesh	99.5
Chromium Sulfide	Cr ₂ S ₃	-200 mesh	99
Chromium Telluride	Cr ₂ Te ₃	-325 mesh	99.5

Co
27

COBALT Base

CHEMICAL	FORMULA	DESCRIPTION	PURITY*
Cobalt	Co	-500 mesh to 3 µm aver. or less	99.8 to 99.99
Cobalt Antimonide	CoSb	-100 mesh	99.99
Cobalt Arsenide	CoAs	-10 mesh	99.5
Cobalt Boride	Co ₂ B	-100 mesh to -325 mesh	99 to 99.9
Cobalt Boride	Co ₃ B	-325 mesh	99.9
Cobalt Bromide	CoBr ₂	-80 mesh	99.9
Cobalt Carbonate	CoCO ₃	-325 mesh	99.5
Cobalt Chloride	CoCl ₂	-80 mesh	99.9
Cobalt Chromium Oxide	CoCr ₂ O ₄	-200 mesh	99.5
Cobalt Fluoride	CoF ₃	-80 mesh	99.5
Cobalt Fluoride	CoF ₂	-80 mesh	99.5
Cobalt Iodide	CoI ₂	-60 mesh	99.5
Cobalt Molybdate	CoMoO ₄	-325 mesh	99.9
Cobalt Oxide	Co ₃ O ₄	-325 mesh to -625 mesh	99.5 to 99.95
Cobalt Oxide	CoO	-425 mesh to -625 mesh	99.95
Cobalt Phosphide	Co ₂ P	-100 mesh	99
Cobalt Samarium	CoSm	-100 mesh	99.95
Cobalt Silicide	CoSi ₂	-325 mesh	99 to 99.5
Cobalt Sulfide	CoS	-200 mesh	99.5
Cobalt Sulfide	CoS ₂	-200 mesh	99.5
Cobalt Titanate	CoTiO ₃	-325 mesh	99.9
Cobalt Tungstate	CoWO ₄	-325 mesh	99.9
Cobalt Zirconate	CoZrO ₃	-325 mesh	99.5

*Purity based on metallic impurities.

Cu
29

COPPER Base

CHEMICAL	FORMULA	DESCRIPTION	PURITY*
Copper	Cu	-20, +50 mesh to 2-5 µm aver. or less	99 to 99.999
Copper Acetate	Cu(C ₂ H ₃ O ₂) ₂ ·H ₂ O	-4 mesh	99.9
Copper Aluminate	CuAl ₂ O ₄	-325 mesh	99.5 to 99.95
Copper Bromide	CuBr	-80 mesh	99 to 99.999
Copper Bromide	CuBr ₂	-80 mesh	99
Copper Chloride	CuCl	-80 mesh	99 to 99.999
Copper Chloride	CuCl ₂	-20 mesh	99
Copper Fluoride	CuF ₂	-100 mesh	99.5
Copper Gallium Selenide	CuGaSe ₂	-325 mesh	99.999
Copper Gallium Telluride	CuGaTe ₂	-325 mesh	99.999
Copper Germanium Selenide	CuGeSe	-100 mesh	99.99
Copper Indium (80/20 at%)	Cu-In	-325 mesh	99.99
Copper Indium Selenide	CuInSe ₂	-325 mesh	99.9 to 99.999
Copper Indium Sulfide	CuInS ₂	-325 mesh	99.999
Copper Indium Telluride	CuInTe ₂	-325 mesh	99.999
Copper Iodide	CuI	-60 mesh to -80 mesh	99 to 99.999
Copper Nitride	Cu ₃ N	-200 mesh	99.5
Copper Oxide	CuO	-200 mesh to -425 mesh	99.7 to 99.999
Copper Oxide	Cu ₂ O	-200 mesh	99
Copper Phosphide	Cu ₃ P	-100 mesh	99.5
Copper Selenide	Cu ₂ Se	-425 mesh	99.999
Copper Sulfate	CuSO ₄ ·5H ₂ O	-4 mesh	99.995
Copper Sulfide	CuS	-100 mesh to -325 mesh	99.5 to 99.999
Copper Sulfide	Cu ₂ S	-80 mesh to -200 mesh	99.5 to 99.99
Copper Telluride	Cu ₂ Te	-625 mesh	99.99
Copper Telluride	CuTe	-200 mesh	99.99
Copper Titanate	CuO·TiO ₂	-325 mesh	99.5
Copper Titanium Selenide	CuTiSe ₂	-325 mesh	99.999
Copper Titanium Telluride	CuTiTe ₂	-325 mesh	99.999
Copper Tungstate	CuWO ₄	-100 mesh to -200 mesh	99.5
Copper Vanadate	CuV ₂ O ₆	-200 mesh	99.5
Copper Zirconate	CuO·ZrO ₂	-200 mesh	99.5

*Purity based on metallic impurities.

Dy
66**DYSPROSIUM Base**

CHEMICAL	FORMULA	DESCRIPTION	PURITY*
Dysprosium	Dy	-40 mesh to -200 mesh	99.9 to 99.95
Dysprosium Boride	DyB ₄ / DyB ₆	-60 mesh	99.5
Dysprosium Bromide	DyBr ₃	-20 mesh	99.9
Dysprosium Chloride	DyCl ₃	-100 mesh	99.99
Dysprosium Chloride	DyCl ₃ ·6H ₂ O	-4 mesh	99.9
Dysprosium Fluoride	DyF ₃	-60 mesh to -325 mesh	99.9 to 99.998
Dysprosium Nitride	DyN	-60 mesh	99.9
Dysprosium Oxide	Dy ₂ O ₃	-325 mesh to -425 mesh	99.9 to 99.999
Dysprosium Sulfide	Dy ₂ S ₃	-200 mesh	99.9
Dysprosium Telluride	Dy ₂ Te ₃	-20 mesh	99.9

Er
68**ERBIUM Base**

CHEMICAL	FORMULA	DESCRIPTION	PURITY*
Erbium	Er	-40 mesh to -325 mesh	99.9
Erbium Boride	ErB ₄	-100 mesh	99.5
Erbium Bromide	ErBr ₃	-20 mesh	99.9
Erbium Chloride	ErCl ₃ / ErCl ₃ ·6H ₂ O	-4 mesh to -20 mesh	99.9 to 99.99
Erbium Fluoride	ErF ₃	-60 mesh to -325 mesh	99.9 to 99.995
Erbium Hydride	ErH ₂₋₃	-60 mesh	99.9
Erbium Iodide	ErI ₃	-20 mesh	99.9
Erbium Nitride	ErN	-60 mesh	99.9
Erbium Oxide	Er ₂ O ₃	-325 mesh	99.9 to 99.999
Erbium Sulfide	Er ₂ S ₃	-200 mesh	99.9

*Purity based on metallic impurities.

Eu

63

EUROPIUM Base

CHEMICAL	FORMULA	DESCRIPTION	PURITY*
Europium	Eu	-40 mesh	99.9
Europium Boride	EuB ₆	-60 mesh	99.5
Europium Chloride	EuCl ₃ / EuCl ₃ ·6H ₂ O	-4 mesh to -20 mesh	99.9
Europium Fluoride	EuF ₂ / EuF ₃	-60 mesh to -325 mesh	99.9
Europium Hydride	EuH ₂₋₃	-60 mesh	99.9
Europium Nitride	EuN	-60 mesh	99.9
Europium Oxide	Eu ₂ O ₃	-325 mesh	99.9 to 99.995
Europium Selenide	EuSe	-100 mesh	99.9
Europium Sulfate	Eu ₂ (SO ₄) ₃ ·8H ₂ O	-200 mesh	99.995
Europium Sulfide	EuS	-200 mesh	99.9
Europium Telluride	EuTe	-20 mesh	99.9

Gd

64

GADOLINIUM Base

CHEMICAL	FORMULA	DESCRIPTION	PURITY*
Gadolinium	Gd	-40 mesh	99.9
Gadolinium Boride	GdB ₆	-325 mesh	99.5
Gadolinium Chloride	GdCl ₃ / GdCl ₃ ·6H ₂ O	-4 mesh to -20 mesh	99.9
Gadolinium Fluoride	GdF ₃	-60 mesh to -325 mesh	99.9
Gadolinium Gallium Oxide (GGG)	Gd ₃ Ga ₅ O ₁₂	-100 mesh	99.9
Gadolinium Hydride	GdH ₂₋₃	-60 mesh	99.9
Gadolinium Nitride	GdN	-60 mesh	99.9
Gadolinium Oxide	Gd ₂ O ₃	-325 mesh	99.9 to 99.999
Gadolinium Sulfide	Gd ₂ S ₃	-200 mesh	99.9
Gadolinium Titanate	Gd ₂ Ti ₂ O ₇	-100 mesh	99.9

*Purity based on metallic impurities.

Ga
31**GALLIUM Base**

CHEMICAL	FORMULA	DESCRIPTION	PURITY*
Gallium Bromide	GaBr ₃	-8 mesh	99.999
Gallium Fluoride	GaF ₃ / GaF ₃ ·3H ₂ O	-20 mesh to -60 mesh	99.5 to 99.998
Gallium Iodide	GaI ₃	-20 mesh	99.999
Gallium Nitride	GaN	-100 mesh	99.9 to 99.995
Gallium Oxide	Ga ₂ O ₃	-325 mesh to -625 mesh	99.995 to 99.9999
Gallium Phosphide	GaP	-100 mesh	99.999
Gallium Selenide	Ga ₂ Se ₃	-160 mesh	99.999
Gallium Sulfide	Ga ₂ S ₃	-100 mesh to -200 mesh	99.95 to 99.999
Gallium Telluride	GaTe	-160 mesh	99.999

Ge
32**GERMANIUM Base**

CHEMICAL	FORMULA	DESCRIPTION	PURITY*
Germanium	Ge	-625 mesh	99.999
Germanium Antimony Telluride (GST)	Ge ₂ Sb ₃ Te ₅	-160 mesh to -325 mesh	99.999
Germanium Iodide	GeI ₂	-10 mesh to -20 mesh	99.999
Germanium Oxide	GeO ₂	-50 mesh to -325 mesh	99.99 to 99.999
Germanium Selenide	GeSe	-160 mesh	99.999
Germanium Sulfide	GeS	-20 mesh to -160 mesh	99.95 to 99.999
Germanium Telluride	GeTe	-200 mesh	99.99 / 99.999

Au
79**GOLD Base**

CHEMICAL	FORMULA	DESCRIPTION	PURITY*
Gold	Au	-325 mesh	99.95 to B99.99
Gold Chloride	AuCl ₃	-8 mesh	99
Gold Oxide	Au ₂ O ₃	-100 mesh	99.5

*Purity based on metallic impurities.

C

6

GRAPHITE Base

CHEMICAL	FORMULA	DESCRIPTION	PURITY*
Graphite	C	-40, +100 mesh to -325 mesh	99.5 to 99.999
Graphite Bromide	C ₈ Br	-100 mesh	99.9
Graphite Fluoride	CF _{1.1-1.5}	-200 mesh	99.9

Hf

72

HAFNIUM Base

CHEMICAL	FORMULA	DESCRIPTION	PURITY*
Hafnium	Hf	-60, +325 mesh to -325 mesh	99.8 to 99.95
Hafnium Boride	HfB ₂	-140, +325 mesh to -425 mesh	99.5 to 99.9
Hafnium Bromide	HfBr ₄	-20 mesh to -100 mesh	99 to 99.99
Hafnium Carbide	HfC	-325 mesh to -625 mesh	99.5 to 99.9
Hafnium Chloride	HfCl ₄	-80 mesh to -100 mesh	98.5 to 99.9
Hafnium Fluoride	HfF ₄	-60 mesh	99.9
Hafnium Hydride	HfH ₂	-325 mesh	99.8
Hafnium Iodide	HfI ₄	-60 mesh to -100 mesh	99.5 to 99.9
Hafnium Nitride	HfN	-325 mesh to -625 mesh	99.5 to 99.8
Hafnium Oxide	HfO ₂	-325 mesh	99.9 to 99.995
Hafnium Oxide Calcium Oxide (90/10 wt%), (85/15 wt%)	HfO ₂ -CaO	-140, +325 mesh to -325 mesh, +10 μm	99
Hafnium Oxide Yttrium Oxide (90/10 wt%), (85/15 wt%)	HfO ₂ -Y ₂ O ₃	-140, +325 mesh to -325 mesh, +10 μm	99
Hafnium Oxychloride	HfOCl ₂ -8H ₂ O	-6 mesh	99 to 99.99
Hafnium Selenide	HfSe ₂	-325 mesh	99.5
Hafnium Silicide	HfSi ₂	-100 mesh to -325 mesh	99.5 to 99.8
Hafnium Telluride	HfTe ₂	-325 mesh	99.5
Hafnium Titanate	HfTiO ₄	-325 mesh	99.5

*Purity based on metallic impurities.

Ho

67

HOLMIUM Base

CHEMICAL	FORMULA	DESCRIPTION	PURITY*
Holmium	Ho	-40 mesh to -60 mesh	99.9 to 99.95
Holmium Boride	HoB ₄	-100 mesh	99.5
Holmium Bromide	HoBr ₃	-20 mesh	99.9
Holmium Chloride	HoCl ₃ / HoCl ₃ ·6H ₂ O	-4 mesh to -20 mesh	99.9 to 99.99
Holmium Fluoride	HoF ₃	-60 mesh to -325 mesh	99.9 to 99.995
Holmium Hydride	HoH ₂₋₃	-60 mesh	99.9
Holmium Nitride	HoN	-60 mesh	99.9
Holmium Oxide	Ho ₂ O ₃	-325 mesh	99.9 to 99.999
Holmium Sulfide	Ho ₂ S ₃	-200 mesh	99.9

In

49

INDIUM Base

CHEMICAL	FORMULA	DESCRIPTION	PURITY*
Indium	In	-325 mesh	99.99 to 99.999
Indium Fluoride	InF ₃	-40 mesh	99.99
Indium Hydroxide	In(OH) ₃	-100 mesh	99.99
Indium Iodide	InI / InI ₃	-8 mesh to -100 mesh	99.99 to 99.999
Indium Nitride	InN	-100 mesh	99.9 to 99.99
Indium Oxide	In ₂ O ₃	-325 mesh to -1250 mesh	99.99 to 99.999
Indium Selenide	In ₂ Se ₃	-160 mesh to -325 mesh	99.9 to 99.999
Indium Sulfate	In ₂ (SO ₄) ₃	-80 mesh	99.99
Indium Sulfide	InS / InS ₂ / In ₂ S ₃	-100 mesh to -200 mesh	99.9 to 99.999
Indium Telluride	In ₂ Te ₃	-325 mesh	99.999
Indium Tin Oxide, ITO (90/10 w%)	In ₂ O ₃ -SnO ₂	-325 mesh to -625 mesh	99.99 to 99.999

*Purity based on metallic impurities.

I

53

IODINE Base

CHEMICAL	FORMULA	DESCRIPTION	PURITY*
Iodine	I_2	-4 mesh	99.9 to 99.999
Iodine Oxide	I_2O_5	-80 mesh	99.9

Ir

77

IRIDIUM Base

CHEMICAL	FORMULA	DESCRIPTION	PURITY*
Iridium	Ir	-325 mesh	99.9
Iridium Chloride	$IrCl_3$	-8 mesh	99.5
Iridium Oxide	IrO_2	-325 mesh	99.9

Fe

26

IRON Base

CHEMICAL	FORMULA	DESCRIPTION	PURITY*
Iron	Fe	-100, +200 mesh to 5 μ m aver. or less	99.9
Iron Aluminide	$FeAl_3 / Fe_3Al$	-325 mesh	99 to 99.9
Iron Boride	FeB / Fe_2B	-35 mesh to -325 mesh	99 to 99.9
Iron Bromide	$FeBr_2$	-20 mesh to -100 mesh	99.5 to 99.98
Iron Carbide	Fe_3C	-325 mesh	99.5
Iron Chloride	$FeCl_2$	-80 mesh	99.5 to 99.99
Iron Chloride	$FeCl_2 / FeCl_3$	-10 mesh to -100 mesh	99.5 to 99.99
Iron Fluoride	FeF_2 / FeF_3	-80 mesh	99.5
Iron Iodide	FeI_2	-60 mesh	99.5
Iron Nitride	FeN	-325 mesh	99.9
Iron Oxide	$FeO / Fe_2O_3 / Fe_3O_4$	-10 mesh to 5 μ m aver. or less	99.5 to 99.997
Iron Phosphide	$FeP / Fe_2P / Fe_3P$	-40 mesh to -200 mesh	99.5
Iron Selenide	FeSe	-40 mesh	99.9
Iron Silicide	$FeSi / FeSi_2$	-20 mesh to -100 mesh	99.95 to 99.99
Iron Sulfide	FeS / FeS_2	-100 mesh	99.9
Iron Titanate	$Fe_2TiO_5 / FeTiO_3$	-100 mesh	99.9
Iron Tungstate	$FeWO_4$	-200 mesh	99.5
Iron Zirconate	$Fe_2O_3-ZrO_2$	-200 mesh	99.7

*Purity based on metallic impurities.

La

57

LANTHANUM Base

CHEMICAL	FORMULA	DESCRIPTION	PURITY*
Lanthanum	La	-40 mesh to -200 mesh	99.9
Lanthanum Aluminate	LaAlO ₃	-50 mesh to -325 mesh	99.9
Lanthanum Boride	LaB ₆	-325 mesh	99.5 to 99.9
Lanthanum Boride	LaB ₆	-100 mesh	99.95
Lanthanum Bromide	LaBr ₃	-10 mesh	99.9
Lanthanum Chloride	LaCl ₃ / LaCl ₃ ·7H ₂ O	-4 mesh to -20 mesh	99.9
Lanthanum Chromite	LaCrO ₃	-200 mesh	99.9
Lanthanum Fluoride	LaF ₃	-60 mesh to -325 mesh	99.9 to 99.995
Lanthanum Iodide	LaI ₃	-10 mesh	99.9
Lanthanum Nickel	LaNi ₅	-100 mesh to -200 mesh	99.5 to 99.9
Lanthanum Nitride	LaN	-60 mesh	99.5 to 99.9
Lanthanum Oxide	La ₂ O ₃	-200 mesh to -400 mesh	99.99 to 99.999
Lanthanum Oxysulfide	La ₂ O ₂ S	-200 mesh	99.9
Lanthanum Sulfide	LaS ₂ / La ₂ S ₃	-200 mesh	99.9

Pb

82

LEAD Base

CHEMICAL	FORMULA	DESCRIPTION	PURITY*
Lead	Pb	-80, +140 mesh to 5 µm aver. or less	99.9 to 99.999
Lead Acetate	Pb(C ₂ H ₃ O ₂) ₂	-8 mesh	99.999
Lead Bromide	PbBr ₂	-80 mesh	99.9 to 99.999
Lead Carbonate	2PbCO ₃ ·Pb(OH) ₂	-100 mesh	99.9
Lead Chloride	PbCl ₂	-80 mesh	99.9 to 99.999
Lead Fluoride	PbF ₂	-100 mesh to -325 mesh	99.99 to 99.995
Lead Iodate	Pb(IO ₃) ₂	-60 mesh	99.9
Lead Iodide	PbI ₂	-100 mesh	99.9 to 99.999
Lead Molybdate	PbMoO ₄	-100 mesh to -200 mesh	99 to 99.999
Lead Niobate	PbNb ₂ O ₆	-200 mesh	99.9
Lead Nitrate	Pb(NO ₃) ₂	-50 mesh	99.999
Lead Oxide	PbO / PbO ₂ / Pb ₃ O ₄	-100 mesh to -425 mesh	99.9 to 99.999
Lead Selenide	PbSe	-180 mesh to -325 mesh	99.99 to 99.999
Lead Sulfide	PbS	-200 mesh	99.99
Lead Tantalate	PbTa ₂ O ₆	-200 mesh	99.9
Lead Telluride	PbTe	-325 mesh	99 to 99.999
Lead Titanate	PbTiO ₃	-325 mesh	99.9
Lead Tungstate	PbWO ₄	-200 mesh	99.9
Lead Zirconate	PbZrO ₃	-325 mesh	99.7

*Purity based on metallic impurities.

Li

3

LITHIUM Base

CHEMICAL	FORMULA	DESCRIPTION	PURITY*
Lithium Aluminate	LiAlO ₂	-100 mesh	99.95
Lithium Aluminum Hydride	LiAlH ₄	-10 mesh	98
Lithium Borate	Li ₂ B ₄ O ₇	-100 mesh	99.95
Lithium Borate	LiBo ₂	-80 mesh to -100 mesh	99.9 to 99.95
Lithium Carbonate	Li ₂ CO ₃	-100 mesh to -325 mesh	99.9 to 99.999
Lithium Chloride	LiCl	-20 mesh to -100 mesh	99.8 to 99.995
Lithium Cobalt Oxide	LiCoO ₂	-325 mesh / -425 mesh	99.5
Lithium Fluoride	LiF	-325 mesh	99.9 to 99.99
Lithium Hydride	LiH	-8 mesh	99.9
Lithium Hydroxide	LiOH·H ₂ O	-100 mesh	99.9
Lithium Iodate	LiIO ₃	-80 mesh	99.9
Lithium Iodide	LiI	-100 mesh	99.95
Lithium Manganese Oxide	LiMn ₂ O ₄	-325 mesh	99.5
Lithium Molybdate	Li ₂ MoO ₄	-200 mesh	99.9
Lithium Niobate	LiNbO ₃	-200 mesh to -325 mesh	99.9 to 99.95
Lithium Nitrate	LiNO ₃	-4 mesh to -40 mesh	99.9 to 99.995
Lithium Nitride	Li ₃ N	-60 mesh	99.5
Lithium Oxide	Li ₂ O	-100 mesh	99.5 to 99.9
Lithium Peroxide	Li ₂ O ₂	-100 mesh	99.5
Lithium Phosphate	Li ₃ PO ₄	-325 mesh	99 to 99.99
Lithium Selenide	Li ₂ Se	-100 mesh	99.5 to 99.9
Lithium Selenite	Li ₂ SeO ₃	-100 mesh	99.5
Lithium Silicate	Li ₂ SiO ₃ / Li ₄ SiO ₄	-100 mesh	99.5
Lithium Sulfide	Li ₂ S	-200 mesh	99.9
Lithium Tantalate	LiTaO ₃	-50 mesh to -200 mesh	99.9 to 99.99
Lithium Tellurite	Li ₂ TeO ₃	-100 mesh	99.5
Lithium Tungstate	Li ₂ WO ₄	-100 mesh	99.9
Lithium Vanadate	LiVO ₃	-100 mesh	99.9
Lithium Zirconate	Li ₂ ZrO ₃	-80 mesh	99

*Purity based on metallic impurities.

Lu
71

LUTETIUM Base

CHEMICAL	FORMULA	DESCRIPTION	PURITY*
Lutetium	Lu	-40 mesh to -325 mesh	99.9 to 99.99
Lutetium Boride	LuB ₄	-100 mesh	99.5
Lutetium Bromide	LuBr ₃	-20 mesh	99.9
Lutetium Chloride	LuCl ₃	-20 mesh	99.9 to 99.99
Lutetium Chloride	LuCl ₃ ·6H ₂ O	-4 mesh	99.9
Lutetium Fluoride	LuF ₃	-325 mesh	99.9 to 99.995
Lutetium Hydride	LuH ₂₋₃	-60 mesh	99.9
Lutetium Nitride	LuN	-60 mesh	99.9
Lutetium Oxide	Lu ₂ O ₃	-325 mesh to -425 mesh	99 to 99.999
Lutetium Sulfide	Lu ₂ S ₃	-200 mesh	99.9 to 99.995
Lutetium Telluride	Lu ₂ Te ₃	-20 mesh to -60 mesh	99.9 to 99.999

Mg
12

MAGNESIUM Base

CHEMICAL	FORMULA	DESCRIPTION	PURITY*
Magnesium	Mg	-100, +200 mesh to -325 mesh	99.6
Magnesium Aluminum Oxide	MgAl ₂ O ₄	-325 mesh to -425 mesh	99 to 99.995
Magnesium Boride	MgB ₂	-100 mesh	99 to 99.9
Magnesium Bromide	MgBr ₂	-40 mesh	99
Magnesium Chloride	MgCl ₂	-100 mesh to -325 mesh	99 to 99.9
Magnesium Fluoride	MgF ₂	-200 mesh to -325 mesh	99.5 to 99.995
Magnesium Germanide	Mg ₂ Ge	-325 mesh	99.99
Magnesium Iodide	MgI ₂	-10 mesh	99.99
Magnesium Molybdate	MgMoO ₄	-200 mesh	99.9
Magnesium Niobate	MgNb ₂ O ₆	-200 mesh	99.9
Magnesium Nitride	Mg ₃ N ₂	-325 mesh	99.5 to 99.9
Magnesium Oxide	MgO	-22 mesh to -425 mesh	95 to 99.998
Magnesium Silicate	Mg ₂ SiO ₄	-325 mesh	99
Magnesium Silicide	Mg ₂ Si	-20 mesh to -325 mesh	99.5 to 99.999
Magnesium Stannate	MgSnO ₃	-325 mesh	99.9
Magnesium Stannide	Mg ₂ Sn	-20 mesh	99.99
Magnesium Sulfate	MgSO ₄	-20 mesh	99.9
Magnesium Tantalate	MgTa ₂ O ₆	-200 mesh	99.9
Magnesium Titanate	MgTiO ₃ / MgTi ₂ O ₅	-325 mesh	99 to 99.9
Magnesium Tungstate	MgWO ₄	-325 mesh	99.9
Magnesium Vanadate	MgV ₂ O ₆	-325 mesh	99.9
Magnesium Zirconate	MgO·ZrO ₂	-100, +200 mesh to -325 mesh, +10 μm	99

*Purity based on metallic impurities.

Mn
25**MANGANESE Base**

CHEMICAL	FORMULA	DESCRIPTION	PURITY*
Manganese	Mn	-100, +200 mesh to -400 mesh	99.6 to 99.99
Manganese Antimonide	Mn ₂ Sb	-100 mesh	99.5
Manganese Boride	MnB / MnB ₂	-80 mesh to -200 mesh	99
Manganese Bromide	MnBr ₂	-80 mesh	99.5
Manganese Carbide	Mn ₂₃ C ₆ / Mn ₂₃ C ₇	-80 mesh to -180 mesh	99.5
Manganese Carbonate	MnCO ₃	-200 mesh	99.95
Manganese Chloride	MnCl ₂	-80 mesh to -325 mesh	99 to 99.9
Manganese Fluoride	MnF ₂ / MnF ₃	-60 mesh to -80 mesh	99.5
Manganese Iodide	MnI ₂	-60 mesh	99.5
Manganese Molybdate	MnMoO ₄	-200 mesh	99.9
Manganese Niobate	MnNb ₂ O ₆	-200 mesh	99.9
Manganese Nitride	Mn ₂₋₄ N	-200 mesh	99.9
Manganese Oxide	MnO	-325 mesh	99.5
Manganese Oxide	MnO ₂	-325 mesh	99.9
Manganese Oxide	Mn ₂ O ₃	-325 mesh	99.9
Manganese Oxide	Mn ₃ O ₄	10 µm aver. or less	99
Manganese Phosphide	Mn ₃ P ₂	-100 mesh	99
Manganese Selenide	MnSe	-20 mesh	99.9
Manganese Silicide	MnSi ₂	-325 mesh	99.5
Manganese Titanate	MnTiO ₃	-100 mesh	99.9
Manganese Tungstate	MnWO ₄	-200 mesh	99.9
Manganese Zirconate	MnO-ZrO ₂	-200 mesh	99.5

Mo
42**MOLYBDENUM Base**

CHEMICAL	FORMULA	DESCRIPTION	PURITY*
Molybdenum	Mo	-140, +325 mesh to 2-4 µm aver. or less	99.9 to 99.95
Molybdenum Aluminide	Mo ₃ Al	-140, +325 mesh to -325 mesh	99.5
Molybdenum Boride	MoB / Mo ₂ B / Mo ₂ B ₃	-325 mesh to -425 mesh	99 to 99.5
Molybdenum Carbide	Mo ₂ C	-325 mesh to -400 mesh	99.5
Molybdenum Chloride	MoCl ₂ / MoCl ₃ / MoCl ₅	-8 mesh to -100 mesh	99.5
Molybdenum Oxide	MoO ₂ / MoO ₃	-40 mesh to -200 mesh	99.9 to 99.995
Molybdenum Phosphide	MoP	-200 mesh	99.5
Molybdenum Selenide	MoSe ₂	-325 mesh	99.9
Molybdenum Silicide	MoSi ₂	-200, +325 mesh to -325 mesh, +10 µm	99.5
Molybdenum Sulfide	MoS ₂	-425 mesh to 1 µm aver. or less	99 to 99.9
Molybdenum Telluride	MoTe ₂	10 µm aver. or less	99.9

*Purity based on metallic impurities.

Nd
60

NEODYMIUM Base

CHEMICAL	FORMULA	DESCRIPTION	PURITY*
Neodymium	Nd	-40 mesh to -200 mesh	99.9
Neodymium Boride	NdB ₆	-200 mesh to -325 mesh	99.5
Neodymium Bromide	NdBr ₃	-20 mesh	99.9
Neodymium Chloride	NdCl ₃	-4 mesh to -20 mesh	99.9 to 99.99
Neodymium Fluoride	NdF ₃	-60 mesh to -325 mesh	99.9 to 99.995
Neodymium Gallate	NdGaO ₃	-200 mesh	99.9
Neodymium Hydride	NdH _{2.3}	-60 mesh	99.9
Neodymium Iodide	NdI ₃	-10 mesh	99.9
Neodymium Nitride	NdN	-60 mesh	99.9
Neodymium Oxide	Nd ₂ O ₃	-325 mesh to -425 mesh	99.9 to 99.999
Neodymium Silicide	NdSi ₂	-325 mesh	99.5
Neodymium Sulfide	Nd ₂ S ₃	-200 mesh	99.9
Neodymium Telluride	Nd ₂ Te ₃	-20 mesh	99.9

Ni
28

NICKEL Base

CHEMICAL	FORMULA	DESCRIPTION	PURITY*
Nickel	Ni	-20, +50 mesh to 1 µm aver. or less	99.9 to 99.95
Nickel Aluminide	NiAl ₃	-20 mesh to -325 mesh	99.9
Nickel Aluminide	NiAl	-100 mesh	99.9
Nickel Aluminum (95/5 wt%)	Ni-Al	-170, +325 mesh	99.5
Nickel Boride	NiB / Ni ₂ B / Ni ₃ B	-35 mesh to -325 mesh	99 to 99.5
Nickel Bromide	NiBr ₂	-60 mesh	99.5 to 99.9
Nickel Carbonate	NiCO ₃	-325 mesh	99.5
Nickel Chloride	NiCl ₂	-10 mesh to -60 mesh	99.5 to 99.999
Nickel Chromium Oxide	NiCr ₂ O ₄	-100 mesh	99 to 99.9
Nickel Cobalt Oxide	NiCoO ₂	-325 mesh	99.5
Nickel Chromium (80/20 wt%)	Ni-Cr	-140, +325 mesh to -325 mesh	97 to 99.98
Nickel Fluoride	NiF ₂	-100 mesh	99.5
Nickel Iodide	NiI ₂	-60 mesh	99.5
Nickel Molybdate	NiMoO ₄	-325 mesh	99
Nickel Oxide	NiO	-100 mesh to -325 mesh	99 to 99.995
Nickel Phosphide	Ni ₂ P	-100 mesh	99.5
Nickel Selenide	NiSe	-200 mesh	99.95
Nickel Silicide	NiSi ₂ / Ni ₂ Si	-20 mesh to -325 mesh	99 to 99.5
Nickel Silicon (62/38 wt%)	Ni-Si	-325 mesh	99.5
Nickel Sulfide	NiS	-200 mesh	99.9
Nickel Titanate	NiTiO ₃	-325 mesh	99.9
Nickel Tungstate	NiWO ₄	-325 mesh	99.9 to 99.95

*Purity based on metallic impurities.

Nb
41

NIOBIUM Base

CHEMICAL	FORMULA	DESCRIPTION	PURITY*
Niobium	Nb	-80, +200 mesh to 10 µm aver. or less	99.8 to 99.99
Niobium Aluminide	NbAl ₃ / Nb ₃ Al	-100 mesh to -325 mesh	99.5
Niobium Boride	NbB / NbB ₂	-100 mesh to -400 mesh	99.5 to 99.8
Niobium Bromide	NbBr ₅	-100 mesh	99.9
Niobium Carbide	NbC / Nb ₂ C	-325 mesh to -400 mesh	99.5
Niobium Chloride	NbCl ₅	-100 mesh	99.95 to 99.99
Niobium Chromide	NbCr ₂	-325 mesh	99.5
Niobium Fluoride	NbF ₅	-80 mesh	99.5
Niobium Gallide	NbGa ₃	-100 mesh	99.5
Niobium Germanide	Nb ₃ Ge	-100 mesh	99.5
Niobium Hydride	NbH _x	-325 mesh	99.5
Niobium Nitride	NbN	-325 mesh to -400 mesh	99.5
Niobium Oxide	NbO / Nb ₂ O ₅	-100 mesh to 10 µm aver. or less	99.9 to 99.998
Niobium Phosphide	NbP	-200 mesh	99.5
Niobium Selenide	NbSe ₂	5 µm aver. or less	99.8
Niobium Silicide	NbSi ₂ / Nb ₅ Si ₃	-325 mesh to -400 mesh	99.5 to 99.9
Niobium Stannide	NbSn ₂ / Nb ₃ Sn	-100 mesh	99.5
Niobium Telluride	NbTe ₂	-325 mesh	99.8

Pd
46

PALLADIUM Base

CHEMICAL	FORMULA	DESCRIPTION	PURITY*
Palladium	Pd	-325 mesh	99.95
Palladium Chloride	PdCl ₂	-8 mesh	99.9
Palladium Oxide	PdO	-20 mesh	99.95

P
15

PHOSPHORUS Base

CHEMICAL	FORMULA	DESCRIPTION	PURITY*
Phosphorus	P	-100 mesh	99.5
Phosphorus Bromide	PBr ₅	-60 mesh	99.9
Phosphorus Chloride	PCl ₅	-60 mesh	99.9
Phosphorus Oxide	P ₂ O ₅	-100 mesh	99.9 to 99.995

*Purity based on metallic impurities.

Pt
78**PLATINUM Base**

CHEMICAL	FORMULA	DESCRIPTION	PURITY*
Platinum	Pt	-325 mesh	99.9
Platinum Chloride	PtCl ₂	-8 mesh / -10 mesh	99.9
Platinum Oxide	PtO ₂ -H ₂ O	-100 mesh	99.9

K
19**POTASSIUM Base**

CHEMICAL	FORMULA	DESCRIPTION	PURITY*
Potassium Borate	K ₂ B ₄ O ₇ -H ₂ O	-6 mesh	99.9
Potassium Borohydride	KBH ₄	-80 mesh	98
Potassium Bromide	KBr	-10 mesh	99.9
Potassium Carbonate	K ₂ CO ₃	-10 mesh to -20 mesh	99.9 to 99.999
Potassium Chloride	KCl	-10 mesh to -20 mesh	99.999
Potassium Fluoride	KF	-60 mesh	99.9
Potassium Hexafluoroantimonate	KSbF ₆	-6 mesh	99.9
Potassium Iodate	KIO ₃ / KIO ₄	-80 mesh to -40 mesh	99.9
Potassium Iodide	KI	-10 mesh to -20 mesh	99.9 to 99.999
Potassium Molybdate	K ₂ MoO ₄	-200 mesh to -325 mesh	99 to 99.9
Potassium Niobate	KNbO ₃	-100 mesh	99.9
Potassium Perrhenate	KReO ₄	-40 mesh	99.9
Potassium Persulfate	K ₂ S ₂ O ₈	-100 mesh	99.9
Potassium Selenate	K ₂ SeO ₄	-100 mesh	99.5
Potassium Selenite	K ₂ SeO ₃	-100 mesh	99.5
Potassium Tantalate	KTaO ₃	-100 mesh	99.9
Potassium Tellurite	K ₂ TeO ₃	-100 mesh	99.5
Potassium Tungstate	K ₂ WO ₄	-100 mesh	99.5
Potassium Vanadate	KVO ₃ / K ₃ VO ₄ / K ₄ V ₂ O ₇	-200 mesh	99.9
Potassium Zirconate	K ₂ ZrO ₃	-200 mesh	99.5

*Purity based on metallic impurities.

Pr

59

PRASEODYMIUM Base

CHEMICAL	FORMULA	DESCRIPTION	PURITY*
Praseodymium	Pr	-40 mesh to -60 mesh	99.9
Praseodymium Boride	PrB ₆	-325 mesh	99.5
Praseodymium Bromide	PrBr ₃	-20 mesh	99.9
Praseodymium Chloride	PrCl ₃	-10 mesh to -100 mesh	99.9
Praseodymium Fluoride	PrF ₃	-60 mesh to -325 mesh	99.9
Praseodymium Hydride	PrH ₂₋₃	-60 mesh	99.9
Praseodymium Nitride	PrN	-60 mesh	99.9
Praseodymium Oxide	Pr ₂ O ₃ / Pr ₆ O ₁₁	-325 mesh	99.9 to 99.999
Praseodymium Silicide	PrSi ₂	-100 mesh to -325 mesh	99.5 to 99.9
Praseodymium Telluride	PrTe	-20 mesh	99.9

Re

75

RHENIUM Base

CHEMICAL	FORMULA	DESCRIPTION	PURITY*
Rhenium	Re	-325 mesh	99.95 to 99.99
Rhenium Boride	ReB	-100 mesh	99.5
Rhenium Chloride	ReCl ₃ / ReCl ₄ / ReCl ₅	-40 mesh to -80 mesh	99.9
Rhenium Iodide	ReI ₃	-80 mesh	99.9
Rhenium Oxide	ReO ₂ / Re ₂ O ₇	-6 mesh to -100 mesh	99.95 to 99.99
Rhenium Selenide	ReSe ₂	-100 mesh	99.9
Rhenium Silicide	ReSi ₂	-80 mesh	99.9
Rhenium Sulfide	ReS ₂	-80 mesh	99.9
Rhenium Telluride	ReTe ₂	-60 mesh	99.9

Rh

45

RHODIUM Base

CHEMICAL	FORMULA	DESCRIPTION	PURITY*
Rhodium	Rh	-325 mesh	99.8 / 99.95

*Purity based on metallic impurities.

Rb

37

RUBIDIUM Base

CHEMICAL	FORMULA	DESCRIPTION	PURITY*
Rubidium Bromide	RbBr	-4 mesh	99.9
Rubidium Carbonate	Rb ₂ CO ₃	-20 mesh to -100 mesh	99.8 to 99.99
Rubidium Chloride	RbCl	-4 mesh to -20 mesh	99.9 to 99.99
Rubidium Chromate	Rb ₂ CrO ₄	-20 mesh	99.9
Rubidium Fluoride	RbF	-4 mesh to -325 mesh	99.9 to 99.99
Rubidium Hydroxide	RbOH·H ₂ O	-4 mesh	99.7
Rubidium Iodate	RbIO ₃	-4 mesh	99.9
Rubidium Iodide	RbI	-4 mesh to -20 mesh	99.9 to 99.99
Rubidium Molybdate	Rb ₂ MoO ₄	-200 mesh	99.5 to 99.9
Rubidium Niobate	RbNbO ₃	-200 mesh	99.5
Rubidium Nitrate	RbNO ₃	-10 mesh to -20 mesh	99.9 to 99.95
Rubidium Perchlorate	RbClO ₄	-4 mesh	99.9
Rubidium Phosphate	RbPO ₃	-325 mesh	99.9 to 99.95
Rubidium Selenide	Rb ₂ Se	-60 mesh to -100 mesh	99.5 to 99.995
Rubidium Sulfate	Rb ₂ SO ₄	-20 mesh	99.9
Rubidium Tantalate	RbTaO ₃	-200 mesh	99.5
Rubidium Tungstate	Rb ₂ WO ₄	-200 mesh	99.5
Rubidium Vanadate	RbVO ₃ / Rb ₄ V ₂ O ₇	-100 mesh to -325 mesh	99.5

Ru

44

RUTHENIUM Base

CHEMICAL	FORMULA	DESCRIPTION	PURITY*
Ruthenium	Ru	-325 mesh	99.95 to 99.99
Ruthenium Bromide	RuBr ₃	-325 mesh	99.99
Ruthenium Chloride	RuCl ₃	-100 mesh	99.9 to 99.95
Ruthenium Oxide	RuO ₂	-100 mesh to -325 mesh	99.9 to 99.99

*Purity based on metallic impurities.

Sm
62**SAMARIUM Base**

CHEMICAL	FORMULA	DESCRIPTION	PURITY*
Samarium	Sm	-200 mesh	99.9
Samarium Boride	SmB ₆	-325 mesh	99.5
Samarium Bromide	SmBr ₃	-20 mesh	99.9
Samarium Chloride	SmCl ₃	-4 mesh to -20 mesh	99.9 to 99.99
Samarium Fluoride	SmF ₃	-60 mesh to -325 mesh	99.9 to 99.995
Samarium Iodide	SmI ₂	-20 mesh	99.9
Samarium Nitride	SmN	-60 mesh	99.9
Samarium Oxide	Sm ₂ O ₃	-325 mesh, -400 mesh	99.9 to 99.995
Samarium Sulfide	Sm ₂ S ₃	-200 mesh	99.9
Samarium Telluride	Sm ₂ Te ₃	-20 mesh	99.9
Samarium Cobalt	Sm ₂ Co ₅ / Sm ₂ Co ₇	-100 mesh to -400 mesh	99.5 to 99.95

Sc
21**SCANDIUM Base**

CHEMICAL	FORMULA	DESCRIPTION	PURITY*
Scandium	Sc	-40 mesh to -325 mesh	99.9 to 99.95
Scandium Boride	ScB ₂	-200 mesh	99.5
Scandium Chloride	ScCl ₃	-20 mesh	99.9
Scandium Fluoride	ScF ₃	-200 mesh	99.9
Scandium Iodide	ScI ₃	-20 mesh	99.9
Scandium Oxide	Sc ₂ O ₃	-325 mesh	99.99
Scandium Sulfide	Sc ₂ S ₃	-200 mesh	99.9

Se
34**SELENIUM Base**

CHEMICAL	FORMULA	DESCRIPTION	PURITY*
Selenium	Se	-20 mesh to -200 mesh	99.6 to 99.999
Selenium Bromide	SeBr ₄	-8 mesh	99.5
Selenium Chloride	SeCl ₄	-8 mesh	99.8
Selenium Oxide	SeO ₂	-20 mesh to -425 mesh	99.5 to 99.999

*Purity based on metallic impurities.

Si

14

SILICON Base

CHEMICAL	FORMULA	DESCRIPTION	PURITY*
Silicon	Si	-20 mesh to 10 µm aver. or less	98 to 99.999
Silicon Boride	SiB ₄ / SiB ₆	-325 mesh	99.5
Silicon Carbide	SiC	-325 mesh to 1 µm aver. or less	99.5 to 99.9
Silicon Dioxide	SiO ₂	-10 mesh to -400 mesh	99.5 to 99.999
Silicon Iodide	SiI ₄	-8 mesh	99.9
Silicon Monoxide	SiO	-325 mesh to -400 mesh	99.9 to 99.99
Silicon Nitride	Si ₃ N ₄ (90% alpha phase)	-325 mesh to -400 mesh	98 to 99.9

Ag

47

SILVER Base

CHEMICAL	FORMULA	DESCRIPTION	PURITY*
Silver	Ag	-20 mesh to 1 µm aver. or less	99.99 to 99.999
Silver Bromide	AgBr	-20 mesh	99.9 to 99.999
Silver Chloride	AgCl	-20 mesh to -100 mesh	99.9 to 99.999
Silver Fluoride	AgF ₂	-40 mesh	99.5
Silver Gallium Selenide	AgGaSe ₂	-325 mesh	99.999
Silver Gallium Telluride	AgGaTe ₂	-325 mesh	99.999
Silver Hexafluoroantimonate	AgSbF ₆	-6 mesh	99.9
Silver Hexafluorophosphate	AgPF ₆	-6 mesh	99.9
Silver Indium Selenide	AgInSe ₂	-325 mesh	99.999
Silver Indium Sulfide	AgInS ₂	-180 mesh	99.999
Silver Iodide	AgI	-20 mesh	99.9 to 99.999
Silver Nitrate	AgNO ₃	-10 mesh	99.9 to 99.999
Silver Oxide	Ag ₂ O	-80 mesh	99.5
Silver Sulfide	Ag ₂ S	-100 mesh	99.9 to 99.999
Silver Titanium Selenide	AgTiSe ₂	-325 mesh	99.999
Silver Titanium Telluride	AgTiTe ₂	-325 mesh	99.999

*Purity based on metallic impurities.

Na
11**SODIUM Base**

CHEMICAL	FORMULA	DESCRIPTION	PURITY*
Sodium Aluminum Fluoride	Na ₃ Al ₃ F ₁₄	-325 mesh	99.5
Sodium Antimonate	NaSb(OH) ₆	-200 mesh	99.9
Sodium Borohydride	NaBH ₄	-80 mesh	98
Sodium Carbonate	Na ₂ CO ₃	-20 mesh	99.9 to 99.999
Sodium Chloride	NaCl	-30 mesh to -40 mesh	99.995 to 99.998
Sodium Fluoride	NaF	-200 mesh to -425 mesh	99 to 99.99
Sodium Iodide	NaI	-20 mesh	99.9
Sodium Molybdate	Na ₂ MoO ₄	-200 mesh	99.9
Sodium Niobate	NaNbO ₃	-100 mesh	99.9
Sodium Selenate	Na ₂ SeO ₄	-100 mesh	99.5
Sodium Selenide	Na ₂ Se	-60 mesh	99.9 to 99.99
Sodium Selenite	Na ₂ SeO ₃	-100 mesh	99.5
Sodium Stannate	Na ₂ Sn(OH) ₆	-100 mesh	99.9
Sodium Sulfide	Na ₂ S	-100 mesh	99.9
Sodium Tantalate	NaTaO ₃	-100 mesh	99.9
Sodium Tellurate	Na ₂ H ₄ TeO ₆	-100 mesh	99.5
Sodium Telluride	Na ₂ Te	-60 mesh	99.9
Sodium Tellurite	Na ₂ TeO ₃	-100 mesh	99.5
Sodium Titanate	Na ₂ Ti ₃ O ₇	-200 mesh	99.9
Sodium Tungstate	Na ₂ WO ₄	-200 mesh	99.9
Sodium Vanadate	NaVO ₃ / Na ₃ VO ₄	-200 mesh	99.9
Sodium Zirconate	Na ₂ ZrO ₃	-200 mesh	99.5

Sr
38**STRONTIUM Base**

CHEMICAL	FORMULA	DESCRIPTION	PURITY*
Strontium Aluminate	SrAl ₂ O ₄	-100 mesh	99.5
Strontium Boride	SrB ₆	-325 mesh	99.5
Strontium Bromide	SrBr ₂	-20 mesh	99.5
Strontium Carbide	SrC ₂	-8 mesh	99
Strontium Carbonate	SrCO ₃	-10 mesh to -200 mesh	99.5 to 99.995
Strontium Chloride	SrCl ₂	-40 mesh	99.5

*Purity based on metallic impurities.

CHEMICAL	FORMULA	DESCRIPTION	PURITY*
Strontium Ferrite	$\text{SrFe}_{12}\text{O}_{19}$	-325 mesh	99.5
Strontium Fluoride	SrF_2	-100 mesh to -325 mesh	99.9 to 99.99
Strontium Hydride	SrH_2	-60 mesh	99.5
Strontium Molybdate	SrMoO_4	-200 mesh to -325 mesh	99.9 to 99.99
Strontium Niobate	SrNb_2O_6	-200 mesh	99.9
Strontium Nitrate	$\text{Sr}(\text{NO}_3)_2$	-8 mesh	99.995
Strontium Oxide	SrO	-100 mesh	99.5
Strontium Selenide	SrSe	-20 mesh	99.5
Strontium Stannate	SrSnO_3	-200 mesh	99.5
Strontium Sulfide	SrS	-100 mesh to -200 mesh	99.9 to 99.995
Strontium Tantalate	SrTa_2O_6	-200 mesh	99.9
Strontium Telluride	SrTe	-20 mesh	99.5
Strontium Titanate	SrTiO_3	-200 mesh to -325 mesh	99.9 to 99.95
Strontium Tungstate	SrWO_4	-200 mesh	99.9
Strontium Zirconate	SrZrO_3	-100, +200 mesh to -325 mesh, +10 μm	99.5

Ta

73

TANTALUM Base

CHEMICAL	FORMULA	DESCRIPTION	PURITY*
Tantalum	Ta	-140, +325 mesh to 2 μm aver. or less	99.9 to 99.995
Tantalum Aluminide	$\text{TaAl}_3 / \text{Ta}_3\text{Al}$	-80 mesh to -400 mesh	99.5 to 99.95
Tantalum Boride	$\text{TaB} / \text{TaB}_2$	-325 mesh	99.5
Tantalum Bromide	TaBr_5	-8 mesh to -10 mesh	99.9 to 99.99
Tantalum Carbide	$\text{TaC} / \text{Ta}_2\text{C}$	-20, +325 mesh to -425 mesh	99.5
Tantalum Chloride	TaCl_5	-4 mesh / -20 mesh	99.99
Tantalum Fluoride	TaF_5	-4 mesh	99.9
Tantalum Nitride	TaN	-400 mesh	99.9
Tantalum Oxide	Ta_2O_5	-325 mesh to 5 μm aver. or less	99.5 to 99.995
Tantalum Phosphide	TaP	-100 mesh	99.5 to 99.95
Tantalum Selenide	TaSe_2	-325 mesh	99.8
Tantalum Silicide	$\text{TaSi} / \text{TaSi}_2 / \text{Ta}_5\text{Si}_3$	-100 mesh to -325 mesh	99.5 to 99.99
Tantalum Sulfide	TaS_2	-325 mesh	99.9 to 99.99
Tantalum Telluride	TaTe_2	-325 mesh	99.8 to 99.99

*Purity based on metallic impurities.

Te

52

TELLURIUM Base

CHEMICAL	FORMULA	DESCRIPTION	PURITY*
Tellurium	Te	-18, +60 mesh to -200 mesh	99.5 to 99.99
Tellurium Bromide	TeBr ₄	-4 mesh	99.9
Tellurium Chloride	TeCl ₄	-8 mesh	99.9
Tellurium Iodide	TeI ₄	-4 mesh	99.9
Tellurium Oxide	TeO ₂ / TeO ₃	-60 mesh to -325 mesh	99.9 to 99.999

Tb

65

TERBIUM Base

CHEMICAL	FORMULA	DESCRIPTION	PURITY*
Terbium	Tb	-40 mesh to -325 mesh	99.9
Terbium Boride	TbB ₆	-325 mesh	99.5
Terbium Chloride	TbCl ₃	-4 mesh to -20 mesh	99.9 to 99.99
Terbium Fluoride	TbF ₃	-325 mesh	99.9
Terbium Hydride	TbH ₂₋₃	-60 mesh	99.9
Terbium Nitride	TbN	-40 mesh / -60 mesh	99.9
Terbium Oxide	Tb ₄ O ₇	-325 mesh to -425 mesh	99.9 to 99.999
Terbium Sulfide	Tb ₂ S ₃	-200 mesh	99.9

Tm

69

THULIUM Base

CHEMICAL	FORMULA	DESCRIPTION	PURITY*
Thulium	Tm	-40 mesh to -325 mesh	99.5 to 99.9
Thulium Bromide	TmBr ₃	-20 mesh	99.9
Thulium Chloride	TmCl ₃	-20 mesh	99.9 to 99.99
Thulium Fluoride	TmF ₃	-200 mesh	99.9
Thulium Hydride	TmH ₂₋₃	-60 mesh	99.9
Thulium Iodide	TmI ₃	-20 mesh	99.9
Thulium Nitride	TmN	-60 mesh	99.5 to 99.9
Thulium Oxide	Tm ₂ O ₃	-325 mesh	99.9 to 99.95
Thulium Sulfide	Tm ₂ S ₃	-200 mesh	99.9

*Purity based on metallic impurities.

Sn
50

TIN Base

CHEMICAL	FORMULA	DESCRIPTION	PURITY*
Tin	Sn	-100, +325 mesh to -400 mesh	99.8 to 99.999
Tin Antimonide	SnSb	-180 mesh	99.99
Tin Bromide	SnBr ₂	-4 mesh	99.5
Tin Chloride	SnCl ₂ / SnCl ₄	-8 mesh / -40 mesh	99.999
Tin Fluoride	SnF ₂ / SnF ₄	-4 mesh to -20 mesh	99 to 99.99
Tin Iodide	SnI ₂ / SnI ₄	-6 mesh	99.5 to 99.999
Tin Monoxide	SnO / SnO ₂	-100 mesh to 1 μm aver. or less	99.9 to 99.999
Tin Oxide Antimony Oxide (90/10 wt%)	SnO ₂ -Sb ₂ O ₃	-425 mesh	99.999
Tin Oxide Tin Fluoride (FTO) (90/10 wt %)	SnO ₂ -SnF ₂	-425 mesh	99.999
Tin Phosphide	SnP	-100 mesh	99.5
Tin Selenide	SnSe	-160 mesh	99.99
Tin Sulfide	SnS / SnS ₂	-8 mesh to -180 mesh	99.5 to 99.999
Tin Telluride	SnTe	-160 mesh	99.999

Ti
22

TITANIUM Base

CHEMICAL	FORMULA	DESCRIPTION	PURITY*
Titanium	Ti	-40, +325 mesh to 1-3 μm	95 to 99.995
Titanium Aluminide	Ti ₃ Al / TiAl	-325 mesh to -400 mesh	99.5 to 99.95
Titanium Aluminum Vanadium (90/6/4 wt%)	Ti-Al-V	-200 mesh	99.5
Titanium Boride	TiB ₂	-325 mesh to -400 mesh	99.5 to 99.8
Titanium Carbide	TiC	-140, +325 mesh to 2 μm aver. or less	99.5 to 99.9
Titanium Carbonitride	TiCN	-325 mesh / -400 mesh	99.5
Titanium Fluoride	TiF ₃ / TiF ₄	-325 mesh	99
Titanium Hydride	TiH ₂	-325 mesh	99
Titanium Iodide	TiI ₄	-20 mesh	99.99
Titanium Nitride	TiN	-100, +325 mesh to -400 mesh	99.5 to 99.9
Titanium Oxide	TiO / TiO ₂ / Ti ₂ O ₃	-100 mesh to -400 mesh	99 to 99.999
Titanium Phosphide	TiP	-100 mesh	97
Titanium Selenide	TiSe ₂	-325 mesh	99.5
Titanium Silicide	TiSi ₂ / Ti ₅ Si ₃	-100, +325 mesh to -400 mesh	99.5
Titanium Sulfide	TiS ₂	-200 mesh	99.8
Titanium Telluride	TiTe ₂	-325 mesh	99.5

*Purity based on metallic impurities.

W

74

TUNGSTEN Base

CHEMICAL	FORMULA	DESCRIPTION	PURITY*
Tungsten	W	-10, +60 mesh to 1-2 μm aver. or less	99.8 to 99.999
Tungsten Boride	WB / W ₂ B / W ₂ B ₅	-325 mesh	99.5
Tungsten Carbide	WC / W ₂ C	-325 mesh, +10 μm to 1 μm aver. or less	99.5 to 99.9
Tungsten Carbide Cobalt (94/6 w%)	WC-Co	-325 mesh	99
Tungsten Carbide Cobalt (88/12 wt%)	(WC,W ₂ C)-Co	-325 mesh, +5 μm	99
Tungsten DiSulfide	WS ₂	-425 mesh	99.9
Tungsten Oxide	WO ₂ / WO ₃	-100 mesh to 5 μm aver. or less	99.9
Tungsten Phosphide	WP	-100 mesh	99.5
Tungsten Rhenium (95/5 wt%)	W-Re	-325 mesh	99.95
Tungsten Selenide	WSe ₂	-325 mesh to 5 μm aver. or less	99.8 to 99.9
Tungsten Silicide	WSi ₂ / W ₃ Si ₃	-100 mesh to -400 mesh	99.5 to 99.995
Tungsten Sulfide	WS ₂	1 μm aver. or less	99.8
Tungsten Telluride	WTe ₂	-325 mesh	99.85

V

23

VANADIUM Base

CHEMICAL	FORMULA	DESCRIPTION	PURITY*
Vanadium	V	-325 mesh	99.9
Vanadium Boride	VB / VB ₂	-325 mesh to -425 mesh	99.5
Vanadium Bromide	VBr ₃	-20 mesh	99.7
Vanadium Carbide	VC	-325 mesh	99.5
Vanadium Chloride	VCl ₃	-4 mesh to -425 mesh	99 to 99.9
Vanadium Fluoride	VF ₄	-100 mesh	99
Vanadium Gallide	V ₃ Ga	-100 mesh	99.5
Vanadium Germanide	V ₃ Ge	-100 mesh	99.5
Vanadium Iodide	VI ₂	-6 mesh	99.5
Vanadium Nitride	VN	-325 mesh to -400 mesh	99.5 to 99.9
Vanadium Oxide	VO / VO ₂ / V ₂ O ₃ / V ₂ O ₅ / V ₆ O ₁₃	-80 mesh to -325 mesh	99.5 to 99.99
Vanadium Selenide	VSe ₂	-325 mesh	99.5
Vanadium Silicide	VSi / VSi ₂ / V ₃ Si	-200 mesh to -425 mesh	99.5
Vanadium Stannide	V ₃ Sn	-100 mesh	99.5
Vanadium Sulfide	V ₂ S ₃	-325 mesh	99.8
Vanadium Telluride	VTe ₂	-325 mesh	99.5

*Purity based on metallic impurities.

Yb
70

YTTERBIUM Base

CHEMICAL	FORMULA	DESCRIPTION	PURITY*
Ytterbium	Yb	-40 mesh to -200 mesh	99.9 to 99.95
Ytterbium Boride	YbB ₆	-325 mesh	99.5
Ytterbium Bromide	YbBr ₃	-20 mesh	99.9
Ytterbium Chloride	YbCl ₃	-20 mesh	99.9 to 99.99
Ytterbium Fluoride	YbF ₃	-60 mesh to -325 mesh	99.9 to 99.995
Ytterbium Hydride	YbH ₂₋₃	-60 mesh	99.9
Ytterbium Nitride	YbN	-60 mesh	99.9
Ytterbium Oxide	Yb ₂ O ₃	-325 mesh to -425 mesh	99.9 to 99.995

Y

39

YTTRIUM Base

CHEMICAL	FORMULA	DESCRIPTION	PURITY*
Yttrium	Y	-40 mesh to -425 mesh	99.9 to 99.95
Yttrium Aluminum Oxide (YAG)	Y ₃ Al ₅ O ₁₂	-100 mesh to -325 mesh	99.9 to 99.99
Yttrium Bromide	YBr ₃	-10 mesh	99.9
Yttrium Chloride	YCl ₂ / YCl ₃	-20 mesh to -325 mesh	99 to 99.99
Yttrium Ferrite	Y ₃ Fe ₅ O ₁₂	-200 mesh	99.9
Yttrium Fluoride	YF ₃	-60 mesh / -325 mesh	99.9
Yttrium Iodide	YI ₃	-20 mesh	99.9
Yttrium Manganate	YMnO ₃	-100 mesh	99.9
Yttrium Nitrate	Y(NO ₃) ₃ ·5H ₂ O	-20 mesh	99.9
Yttrium Nitride	YN	-60 mesh	99.9
Yttrium Oxide	Y ₂ O ₃	-140, +325 mesh to -325 mesh	99.9 to 99.9999
Yttrium Silicate	Y ₂ SiO ₅	-400 mesh	99.9
Yttrium Silicide	YSi ₂	-325 mesh	99.9
Yttrium Sulfide	Y ₂ S ₃	-200 mesh	99.9
Yttrium Telluride	Y ₂ Te ₃	-20 mesh to -40 mesh	99.9 to 99.995

*Purity based on metallic impurities.

Zn
30

ZINC Base

CHEMICAL	FORMULA	DESCRIPTION	PURITY*
Zinc	Zn	-20 mesh to -400 mesh	99.9 to 99.95
Zinc Aluminum (98/2 wt%)	Zn-Al	-325 mesh	99.999
Zinc Antimonide (98/2 wt%)	Zn-Sb	-200 mesh	99.99
Zinc Arsenide	Zn ₃ As ₂ / ZnAs ₂	-20 mesh to -325 mesh	99 to 99.999
Zinc Bromide	ZnBr ₂	-40 mesh	99.5
Zinc Chloride	ZnCl ₂	-8 mesh to -10 mesh	99.5 to 99.99
Zinc Fluoride	ZnF ₂	-4 mesh to -100 mesh	99 to 99.99
Zinc Iodide	ZnI ₂	-8 mesh	99.9
Zinc Nitride	Zn ₃ N ₂	-200 mesh	99.9
Zinc Oxide	ZnO	-200 mesh to -325 mesh	99.9 to 99.999
Zinc Phosphide	Zn ₃ P ₂	-180 mesh	99.999
Zinc Selenide	ZnSe	-200 mesh to -325 mesh	99 to 99.999
Zinc Sulfide	ZnS	-200 mesh to 1 µm aver. or less	99 to 99.999
Zinc Telluride	ZnTe	-200 mesh to -325 mesh	99.99 to 99.999
Zinc Titanate	ZnTiO ₃	-200 mesh	99.9
Zinc Tungstate	ZnWO ₄	-200 mesh	99.9

Zr
40

ZIRCONIUM Base

CHEMICAL	FORMULA	DESCRIPTION	PURITY*
Zirconium	Zr	-50 mesh to 2-5 µm	94 to 99.8
Zirconium Boride	ZrB ₂ / ZrB ₁₂	-200 mesh to -400 mesh	99.5
Zirconium Boride Molybdenum Silicide (90/10 wt%)	ZrB ₂ -MoSi ₂	-100 mesh	99.5
Zirconium Bromide	ZrBr ₄	-40 mesh	99.8
Zirconium Carbide	ZrC	-140, +325 mesh to -400 mesh	99.5
Zirconium Chloride	ZrCl ₄	-10 mesh	99.9
Zirconium Disilicide	ZrSi ₂	-325 mesh	99.9
Zirconium Fluoride	ZrF ₄	-4 mesh	99.9 to 99.997
Zirconium Hydride	ZrH ₂	-325 mesh	99.7
Zirconium Iodide	ZrI ₄	-6 mesh	99.5
Zirconium Nitride	ZrN	-325 mesh to -425 mesh	99.5
Zirconium Oxide	ZrO ₂	-325 mesh to 3 µm aver. or less	99 to 99.995
Zirconium Oxide Yttrium Oxide, YSZ (94.8/5.2 at%), (90/10 at%), (87/13 at%), (85/15 at%)	ZrO ₂ -Y ₂ O ₃	-325 mesh to 3 µm aver. or less	99 to 99.95
Zirconium Phosphide	ZrP	-100 mesh	99.5

*Purity based on metallic impurities.

CHEMICAL	FORMULA	DESCRIPTION	PURITY*
Zirconium Selenide	ZrSe ₂	-325 mesh	99.5
Zirconium Silicate	ZrSiO ₄	-200 mesh, +10 μm to -325 mesh	99
Zirconium Silicide	ZrSi ₂	-325 mesh, -400 mesh	99.5
Zirconium Sulfate	Zr(SO ₄) ₂	-325 mesh	99.9
Zirconium Sulfide	ZrS ₂	-200 mesh	99
Zirconium Telluride	ZrTe ₂	-325 mesh	99.5
Zirconium Titanate	ZrTiO ₄	-325 mesh	99.5 to 99.9
Zirconium Tungstate	Zr(WO ₄) ₂	-200 mesh	99.7

*Purity based on metallic impurities.

Nanopowders

Nanostructured materials have dimensions typically ranging from 1 to 100 nm. Nanoparticle research is currently an area of intense scientific interest due to a wide variety of potential applications in biomedical, optical and electronic fields.

CHEMICAL	FORMULA	AVERAGE PARTICLE SIZE (nm)	SPECIFIC SURFACE AREA (m ² /g)	PURITY*
Aluminum	Al	80	-	99.9
Aluminum	Al	18	40 - 60	99+ / 99.9
Aluminum Hydroxide	Al(OH) ₃	50	-	99.5
Aluminum Nitride	AlN	< 50	75 / 78	99
Aluminum Oxide	Al ₂ O ₃ (alpha phase)	80	< 10	99+
Aluminum Oxide	Al ₂ O ₃ (alpha phase)	200	3.9	99.9
Aluminum Oxide	Al ₂ O ₃ (alpha phase)	150	5 - 15	99.8 / 99.85 / 99.97
Aluminum Oxide	Al ₂ O ₃ (alpha phase - contains 5 - 10% gamma phase)	27 - 43	35	99.5
Aluminum Oxide	Al ₂ O ₃ (alpha phase)	~ 100	13 - 15	99.99
Aluminium Oxide	Al ₂ O ₃ (gamma phase)	20	-	99+
Aluminum Oxide	Al ₂ O ₃ (gamma phase)	20 - 30	180	99.97
Aluminum Oxide	Al ₂ O ₃ (gamma phase)	10 - 20	> 160	99
Aluminum Oxide	Al ₂ O ₃ (gamma phase)	20 - 50	> 200	99.9 / 99.99
Antimony Oxide	Sb ₂ O ₃	90 - 210	15.6	99.9
Antimony Oxide	Sb ₂ O ₃	80	-	99.9
Antimony Tin Oxide, ATO (90/10 wt%)	SnO ₂ -Sb ₂ O ₃	~ 100	-	99.95

*Purity based on metallic impurities.

CHEMICAL	FORMULA	AVERAGE PARTICLE SIZE (nm)	SPECIFIC SURFACE AREA (m ² /g)	PURITY*
Antimony Tin Oxide, ATO (90/10 wt%)	SnO ₂ -Sb ₂ O ₃	10 - 20	40 - 50	99.95
Barium Ferrite	BaFe ₉ O ₁₂	60/500	-	99.5
Barium Titanate	BaTiO ₃	~ 50	~ 20	99.95
Barium Titanate	BaTiO ₃	~ 100	> 10	99.9/99.95
Barium Titanate	BaTiO ₃	500	2.0 - 2.2	99.9
Barium Titanate	BaTiO ₃	400	2.6 - 2.8	99.9
Barium Titanate	BaTiO ₃	300	3.5 - 3.7	99.9
Barium Titanate	BaTiO ₃	200	5.0 - 5.6	99.9
Bismuth Oxide	Bi ₂ O ₃	90 - 210	~ 3.5	99.8+
Bismuth Oxide	Bi ₂ O ₃	200	-	99.9
Boron	B	< 80	-	99.9
Boron Carbide	B ₄ C	50	> 42	99
Boron Nitride	BN	137	19.4	99
Boron Oxide	B ₂ O ₃	30	-	99.5
Calcium Carbonate	CaCO ₃	15 - 40	-	97.5
Cerium Oxide	CeO ₂	50 - 80	11 - 17	99.97
Cerium Oxide	CeO ₂	50 - 105	8 - 15	99.9
Cerium Oxide	CeO ₂	15 - 30	30 - 50	99.9
Cesium Dihydrogenphosphate	CsH ₂ PO ₄	45	~ 80	99.5
Chromium	Cr	50	-	99/99.5
Chromium Oxide	Cr ₂ O ₃	60	-	99+/99.9+
Cobalt	Co	28	40 - 60	99.8/99.9
Cobalt Oxide	CoO	50	> 30	99.5
Cobalt Oxide	Co ₃ O ₄	~ 30	> 40	99.8+
Cobalt Oxide	Co ₃ O ₄	50 - 80	~ 10	99
Cobalt Iron Oxide	CoFe ₂ O ₄	20 - 50	-	99.9
Cobalt Iron Oxide	CoFe ₂ O ₄	35 - 55	-	98
Cobalt Nickel Iron Oxide	Co _{0.5} Ni _{0.5} Fe ₂ O ₄	20 - 50	-	99.9
Cobalt Zinc Iron Oxide	Co _{0.5} Zn _{0.5} Fe ₂ O ₄	20 - 50	-	99.9
Cobalt Zinc Iron Oxide	Co _{0.5} Zn _{0.5} Fe ₂ O ₄	30 - 50	-	99.5
Copper	Cu	25	30 - 50	99.8/99.9
Copper	Cu	50	-	99.8
Copper	Cu	100	6.8	99.9+
Copper	Cu	500	-	99
Copper	Cu	78	8.46	99.8
Copper Oxide	CuO	40 - 80	-	99.9
Copper Oxide	CuO	12	-	99.5
Copper Oxide	CuO	30 - 50	13.1	99+
Carbon (Diamond)	C	4 - 25	360 - 420	52 - 65
Carbon (Diamond)	C	3 - 6	200 - 450	97
Carbon (Diamond)	C	3 - 5	278 - 335	95+
Carbon (Diamond)	C	6	282.83	98+
Carbon (Graphite)	C	400/1 μm	-	99.9

*Purity based on metallic impurities.

CHEMICAL	FORMULA	AVERAGE PARTICLE SIZE (nm)	SPECIFIC SURFACE AREA (m ² /g)	PURITY*
Dysprosium Oxide	Dy ₂ O ₃	55	~ 20	99.9
Dysprosium Oxide	Dy ₂ O ₃	30	-	99.9
Erbium Oxide	Er ₂ O ₃	41 - 53	13 - 17	99.9
Erbium Oxide	Er ₂ O ₃	20 - 30	-	99.9
Europium Oxide	Eu ₂ O ₃	45 - 58	14 - 18	99.99/99.995
Europium Oxide	Eu ₂ O ₃	30 - 50	36	99.99
Gadolinium Oxide	Gd ₂ O ₃	20 - 80	10 - 40	99.9+
Gadolinium Oxide	Gd ₂ O ₃	15 - 30	30 - 50	99.9
Gold	Au	50 - 100	3.3	99.99+
Gold	Au	< 100	1.3 - 2.2	99.5+
Hafnium Oxide	HfO ₂	100 - 200	-	99.99
Indium Hydroxide	In(OH) ₃	20 - 70	12.8	99.99
Indium Oxide	In ₂ O ₃	30 - 70	15	99.99
Indium Tin Oxide, ITO (90/10 wt%)	In ₂ O ₃ -SnO ₂	20 - 70	24	99.99
Indium Tin Oxide, ITO (95/5 wt%)	In ₂ O ₃ -SnO ₂	30 - 50	20	99.99
Iron	Fe	100 - 250	3 - 7	98+
Iron	Fe	60 - 80	7	99.9
Iron	Fe	25	40 - 60	99.5
Iron Oxide	Fe ₂ O ₃	20 - 50	-	99.9
Iron Oxide	Fe ₂ O ₃	9	-	99.5
Iron Oxide	Fe ₂ O ₃ (alpha phase)	20 - 60	20 - 60	98
Iron Oxide	Fe ₂ O ₃ (gamma phase)	20 - 30	> 40	98
Iron Oxide	Fe ₃ O ₄	20 - 50	-	99.9
Iron Oxide	Fe ₃ O ₄	20 - 30	> = 40	98+
Iron Oxide	Fe ₃ O ₄	15 - 20	81.98	99.5+
Lanthanum Boride	LaB ₆	50 - 80	-	99+
Lanthanum Oxide	La ₂ O ₃	~ 80	-	99.995
Lanthanum Oxide	La ₂ O ₃	15 - 30	20 - 40	99.99
Lanthanum Strontium Manganese Oxide	La _{0.15} Sr _{0.85} MnO ₃	35	-	99.5
Magnesium Oxide	MgO	~ 30	> 50	99.9
Magnesium Oxide	MgO	100	-	99
Magnesium Oxide	MgO	20	~ 50	99
Manganese Iron Oxide	MnFe ₂ O ₄	20 - 50	-	99.9
Manganese Oxide	Mn ₂ O ₃	40 - 60	-	98+
Molybdenum	Mo	70	-	99.5
Molybdenum	Mo	100	-	99+
Molybdenum Oxide	MoO ₃	100	-	99.5
Neodymium Oxide	Nd ₂ O ₃	~ 80	8 - 12	99.9+
Neodymium Oxide	Nd ₂ O ₃	49 - 64	13 - 17	99.9
Neodymium Oxide	Nd ₂ O ₃	15 - 30	30 - 50	99.9
Nickel	Ni	30 - 50	12	99.7

*Purity based on metallic impurities.

CHEMICAL	FORMULA	AVERAGE PARTICLE SIZE (nm)	SPECIFIC SURFACE AREA (m ² /g)	PURITY*
Nickel	Ni	20	8 - 10/40 - 60	99.8/99.9+
Nickel Iron Oxide	NiFe ₂ O ₄	20 - 50	-	99.9
Nickel Iron Oxide	NiFe ₂ O ₄	20 - 30	59	98
Nickel Oxide	NiO	~ 20	> 50	99.9
Nickel Oxide	NiO	100	~ 6	99
Nickel Zinc Iron Oxide	Ni _{0.5} Zn _{0.5} Fe ₂ O ₄	20 - 50	-	99.9
Nickel Zinc Iron Oxide	Ni _{0.5} Zn _{0.5} Fe ₂ O ₄	10 - 30	-	98.5
Niobium Oxide	Nb ₂ O ₅	~ 500	-	99.9
Praseodymium Oxide	Pr ₆ O ₁₁	15 - 30	30 - 50	99.9
Samarium Oxide	Sm ₂ O ₃	30 - 50	12 - 20	99.9
Samarium Oxide	Sm ₂ O ₃	42 - 55	18 - 22	99.9
Samarium Oxide	Sm ₂ O ₃	15 - 30	30 - 50	99.9
Silicon	Si	50 - 70	30 - 50	98+
Silicon	Si	130	-	99.5
Silicon	Si	30 - 50	70 - 80	98+
Silicon	Si	20 - 30	-	98+
Silicon	Si	60	80	99
Silicon Carbide	SiC (beta phase)	50 - 60	80	95/99
Silicon Carbide	SiC (beta phase)	45 - 55	-	97.5
Silicon Carbide	SiC (beta phase)	10	150 - 200	97+
Silicon Carbide (97/8 wt%),(98/2 wt%)	Si-C	15	~ 90	99+
Silicon Nitride	Si ₃ N ₄	20	110	99
Silicon Nitride	Si ₃ N ₄	15 - 30	103 - 123	98.5+
Silicon Oxide	SiO ₂	80	440	99+
Silicon Oxide	SiO ₂	20 - 60	400 - 600	99.9
Silicon Oxide	SiO _x (x=1.2-1.6)	20	160	99.5
Silicon Oxide	SiO _x (x=1.2-1.6)	15	~ 640	99.5
Silver	Ag	~ 150	-	99.95
Silver	Ag	100 - 500	2 - 8.5	99.95
Silver	Ag	40 - 90	-	99.95
Silver	Ag	500 - 1200	-	99.95
Silver	Ag	90 - 210	2.40 - 4.42	99
Silver	Ag	35	30 - 50	99.5/99.9
Strontium Hexaluminate	SrAl ₁₂ O ₁₉	20 - 40	~ 60	99.5
Strontium Titanate	SrTiO ₃	~ 100	> 10	99.8/99.95
Terbium Oxide	Tb ₄ O ₇	46 - 60	13 - 17	99.95
Tin	Sn	100	-	99.8
Tin Oxide	SnO ₂	10 - 20	-	99.5
Tin Oxide	SnO ₂	~ 80	~ 11	99.9
Tin Oxide	SnO ₂	61	14.2	99.5
Titanium	Ti	30 - 50	12	99
Titanium	Ti	60 - 80	13.8	99
Titanium Boride	TiB ₂	20 - 30	-	80 - 90
Titanium Carbide	TiC	80 - 130	~ 35	98+

*Purity based on metallic impurities.

CHEMICAL	FORMULA	AVERAGE PARTICLE SIZE (nm)	SPECIFIC SURFACE AREA (m ² /g)	PURITY*
Titanium Carbide	TiC	40	-	99
Titanium Carbide	TiC	20 - 30	> 50	99
Titanium Nitride	TiN	10 - 20	80/40 - 55	97
Titanium Oxide	TiO ₂	~ 40	> 40	99.9
Titanium Oxide	TiO ₂	200	-	99
Titanium Oxide	TiO ₂	30 - 40	~ 30	99
Titanium Oxide	TiO ₂	15	~ 240	99
Titanium Oxide	TiO ₂	10 - 30	200 - 220	99
Tungsten	W	40 - 60	-	99.9+
Tungsten Carbide	WC	150 - 200	-	99.95
Tungsten Carbide	WC	500	-	99.5
Tungsten Carbide Cobalt (85/15 at%), (95/5 at%)	WC-Co	40 - 80	-	99.9
Tungsten Carbide Cobalt (92/8 wt%)	WC-Co	60 - 250	1.5	99.5
Tungsten Oxide	WO ₃	~ 40/60/80	-	99.9
Tungsten Oxide	WO ₃	30 - 70	-	99+
Tungsten Oxide	WO ₃	60 - 120	-	99.5
Ytterbium Fluoride	YbF ₃	40 - 80	~ 100	99
Yttrium Aluminum Oxide	Y ₃ Al ₅ O ₁₂	40	-	99
Yttrium Cerium Aluminum Oxide	(Y _{2.98} Ce _{0.02})Al ₅ O ₁₂	15 - 40	-	99.5
Yttrium Neodymium Aluminum Oxide	(Y _{2.98} Nd _{0.02})Al ₅ O ₁₂	40/300	-	99.5
Yttrium Oxide	Y ₂ O ₃	30 - 50	30 - 50	99.95
Yttrium Oxide	Y ₂ O ₃	32 - 36	33 - 37	99.9
Yttrium Oxide	Y ₂ O ₃	20 - 40	30 - 50/~ 42	99.99/99.995
Zinc	Zn	~ 120	6 - 8	99.8
Zinc	Zn	130	5 - 7/6.4	99.5
Zinc	Zn	100	30 - 50	99.9+
Zinc	Zn	80	-	99.5
Zinc	Zn	35	30 - 50	99.9
Zinc Iron Oxide	ZnFe ₂ O ₄	15 - 30	-	98.5
Zinc Iron Oxide	ZnFe ₂ O ₄	20 - 50	-	99.9
Zinc Oxide	ZnO	~ 30	~ 35	99.7
Zinc Oxide	ZnO	90 - 210	4.9 - 6.8	99.9+
Zinc Oxide	ZnO	20	50	99.5
Zirconium Carbide	ZrC	30 - 60	70	97+
Zirconium Oxide	ZrO ₂	30 - 60	15 - 40	> 99.9
Zirconium Oxide	ZrO ₂	50	-	99.5
Zirconium Oxide	ZrO ₂	20	-	99
Zirconium Oxide Calcium Oxide (92/8 at%)	ZrO ₂ -CaO	20 - 30	30 - 60	99.9

*Purity based on metallic impurities.

CHEMICAL	FORMULA	AVERAGE PARTICLE SIZE (nm)	SPECIFIC SURFACE AREA (m ² /g)	PURITY*
Zirconium Oxide Yttrium Oxide, YSZ (97/3 at%), (92/8 at%)	ZrO ₂ -Y ₂ O ₃	30 - 60	15 - 40	> 99.9
Zirconium Oxide Yttrium Oxide, YSZ (97/3 at%)	ZrO ₂ -Y ₂ O ₃	65	15	99.95
Zirconium Oxide Yttrium Oxide, YSZ (97/3 at%), (92/8 at%)	ZrO ₂ -Y ₂ O ₃	20 - 30	30 - 60	99.9
Zirconium Oxide Yttrium Oxide, YSZ (92/8 at%)	ZrO ₂ -Y ₂ O ₃	200 - 300	-	99.9

*Purity based on metallic impurities.

Thermal Spray Powders

THERMAL SPRAY PROCESSES

- Plasma spray
- Flame spray
- High velocity oxy-fuel coating spray (HVOF)
- Electric arc spray
- Cold spray

HARDNESS MEASUREMENT METHODS

Rockwell Hardness (HRB or HRC) is a method of measuring the hardness of materials. Hardness, in this sense, means resistance to penetration. The test gets its name from Stanley P. Rockwell who devised the test and original machines, later selling the rights. The test measures the hardness by pressing an indenter into the surface of the steel with a specific load and then measuring how far the indenter was able to penetrate.

The Vickers (HV) test was developed in England in 1925 and was formally known as the Diamond Pyramid Hardness (DPH) test. The Vickers test has two distinct force ranges, micro (10 g to 1000 g) and macro (1 kg to 100 kg), to cover all testing requirements. The indenter is the same for both ranges therefore Vickers hardness values are continuous over the total range of hardness for metals (typically HV100 to HV1000).

*Purity based on metallic impurities.

CERAMIC POWDERS

CHEMICAL	FORMULA	POWDER FEATURE	PARTICLE SIZE (µm)	PURITY* (%)	MELTING POINT (°C)	HARDNESS
Aluminum Oxide	Al ₂ O ₃	Fused	-70,+30	99	2040	HRC70
Aluminum Oxide Titanium Oxide (87/13 wt%)	Al ₂ O ₃ -TiO ₂	Fused	-70,+30	99.9	1900	HRC70
Aluminum Oxide Titanium Oxide (80/20 wt%)	Al ₂ O ₃ -TiO ₂	Sintered	-70,+30	99.9	1890	HRC70
Aluminum Oxide Titanium Oxide (60/40 wt%)	Al ₂ O ₃ -TiO ₂	Sintered	-70,+30	99.9	1850	HRC60
Titanium Oxide	TiO ₂	Fused	-70,+30	98	1930	HRC60
Chromium Oxide	Cr ₂ O ₃	Fused	-70,+30	98	2440	HRC70
Chromium Oxide Titanium Oxide Silicon Oxide (92/3/5 wt%)	Cr ₂ O ₃ -TiO ₂ -SiO ₂	Sintered	-70,+30	99.9	2400	HRC70
Zirconium Oxide Yttrium Oxide, YSZ (87/13 wt%)	ZrO ₂ -Y ₂ O ₃	Sintered	-70,+30	99.9	2500	HRC40

CARBIDE POWDERS

CHEMICAL	FORMULA	POWDER FEATURE	PARTICLE SIZE (µm)	PURITY* (%)	MELTING POINT (°C)	HARDNESS
Tungsten Carbide	WC	Agglomerated and sintered	-100,+40 / -70,+40	99.9	2730	HV1200
Chromium Carbide	Cr ₃ C ₂	Agglomerated and sintered	-100,+40 / -70,+40	99	2530	HV2500
Titanium Carbide	TiC	Agglomerated and sintered	-100,+40 / -70,+40	99.5	3100	HV2800
Molybdenum Carbide	Mo ₂ C	Agglomerated and sintered	-100,+40 / -70,+40	99.5	2410	HV1500

CHROMIUM CARBIDE COMPOSITE POWDERS

CHEMICAL	FORMULA	POWDER FEATURE	PARTICLE SIZE (µm)	PURITY* (%)	MELTING POINT (°C)	HARDNESS
Nickel Chromium Chromium Carbide (16/4/80 wt%)	Ni-Cr-Cr ₃ C ₂	Blend	-100,+40 / -80,+40 / -70,+40	99.9	1410	HRC40
Nickel Chromium Chromium Carbide (50/20/5/25 wt%)	Ni-Cr-Cr ₃ C ₂	Dense Covered	-100,+40 / -80,+40 / -70,+40	99.9	1410	HRC40
Nickel Chromium Carbide (25/75 wt%)	Ni-Cr ₃ C ₂	Dense Covered	-100,+40 / -80,+40 / -70,+40	99.9	1470	HRC40
Nickel Chromium Aluminum Chromium Carbide (64/19/4/8/5 wt%)	Ni-Cr-Al-Cr ₃ C ₂	Porous Covered	-100,+40 / -80,+40	99.9	670	HRC50

*Purity based on metallic impurities.

MOLYBDENUM COMPOSITE POWDERS

CHEMICAL	FORMULA	POWDER FEATURE	PARTICLE SIZE (µm)	PURITY* (%)	MELTING POINT (°C)	HARDNESS
Molybdenum	Mo	Agglomerated and sintered, spherical	-100,+44 / -90,+44 / -70,+44	99.9	2611	HRA60~70
Molybdenum Nickel Chromium Boron Silicon (75/25 wt%)	Mo-NiCrBSi	Blended	-100,+44 / -90,+44 / -70,+44	99.9	1030	HRC40~50
Molybdenum Nickel Chromium Boron Silicon (70/30 wt%)	Mo-NiCrBSi	Blended	-100,+44 / -90,+44 / -70,+44	99.9	1030	HRC40~50
Molybdenum Nickel Chromium Boron Silicon (30/70 wt%)	Mo-NiCrBSi	Blended	-100,+44 / -90,+44 / -70,+44	99.9	1030	HRC50~60
Molybdenum Nickel Chromium Boron Silicon (75/25 wt%)	Mo-NiCrBSi	Agglomerated and sintered, spherical	-100,+44 / -90,+44 / -70,+44	99.9	1030	HRC40~50
Molybdenum Nickel Chromium Boron Silicon (70/30 wt%)	Mo-NiCrBSi	Agglomerated and sintered, spherical	-100,+44 / -90,+44 / -70,+44	99.9	1030	HRC40~50
Molybdenum Chromium Carbide Nickel Chromium (50/15/35 wt%), (50/10/40 wt%), (40/10/50 wt%)	Mo-Cr ₃ C ₂ -NiCr	Blended	-100,+44 / -90,+44 / -70,+44	99.9	1410	HRC40~50
Molybdenum Aluminum Silicon (50/50 wt%)	Mo-AlSi	Blended	-100,+44 / -90,+44 / -70,+44	99.9	1410	HRC40~50

ALLOY POWDERS

CHEMICAL	FORMULA	POWDER FEATURE	PARTICLE SIZE (µm)	PURITY* (%)	MELTING POINT (°C)	HARDNESS
Nickel Chromium Boron Silicon (85/8-10/1.5-2.5/2-3 wt%)	Ni-Cr-B-Si	Atomized, spherical	-100,+40	99.9	1060	HRB35
Nickel Chromium Boron Silicon Carbon (70/15-20/3-4.5/3.5-5/0.5-1 wt%)	Ni-Cr-B-Si-C	Atomized, spherical	-100,+40	99.9	1035	HRB60
Nickel Chromium (20/80 wt%)	Ni-Cr	Atomized, spherical	-100,+40	99.9	1400	HRB90
Aluminum Silicon (88/12 wt%)	Al-Si	Atomized	-100,+40	99.9	660	HRB90

*Purity based on metallic impurities.

SELF-BONDING COMPOSITE POWDERS

CHEMICAL	FORMULA	POWDER FEATURE	PARTICLE SIZE (µm)	PURITY* (%)	MELTING POINT (°C)	HARDNESS
Nickel Aluminum (90/10 wt%)	Ni-Al	Dense Covered	-100,+40 / -70,+40	99.9	660	HRB80
Nickel Aluminum (5/95 wt%)	Ni-Al	Porous Covered	-100,+40 / -70,+40	99.9	660	HRB80
Nickel Molybdenum Aluminum (90/5/5 wt%)	Ni-Mo-Al	Porous Covered	-100,+40	99.9	660	HRB80
Nickel Chromium Aluminum (76/19/5 wt%)	Ni-Cr-Al	Porous Covered	-100,+40	99.9	660	HRB80
Nickel Chromium Aluminum Cobalt (72/18/5/5 wt%)	Ni-Cr-Al-Co	Porous Covered	-100,+40	99.9	660	HRB70
Nickel Chromium Aluminum Yttrium Oxide (74.5/18.6/2/5 wt%)	Ni-Cr-Al-Y ₂ O ₃	Porous Covered	-100,+40	99.9	660	HRB70

TUNGSTEN CARBIDE COMPOSITE POWDERS

CHEMICAL	FORMULA	POWDER FEATURE	PARTICLE SIZE (µm)	PURITY* (%)	MELTING POINT (°C)	HARDNESS
Cobalt Tungsten Carbide (12/88 wt%)	Co-WC	Dense Covered	-100,+40 / -70,+40	99.9	1280	HRC50
Nickel Tungsten Carbide (12/88 wt%)	Ni-WC	Dense Covered	-100,+40 / -70,+40	99.9	1460	HRC50

*Purity based on metallic impurities.



neyco

30 avenue de la Paix
92170 Vanves - France
Tel: +33(0)1 41 90 50 50
Fax: +33(0)1 41 90 50 51

www.neyco.fr



Materials B 2018-1

neyco

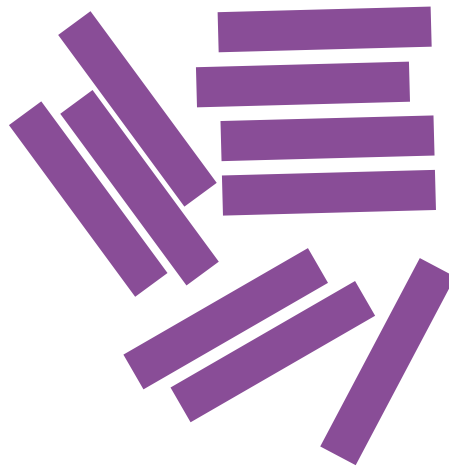

MATERIALS PELLETS

- Vacuum Deposition Grade Pellets C 03

Granules, pellets, pieces, tablets and shaped sources are available in virtually any known inorganic composition and range of purities.

PURITY

Purity is based on spectrographic values of trace metals found, i. e. 99.999% pure indicates that 0.001% (10 ppm) total of trace metals have been observed. 99.9% pure implies a total metallic impurity content of 0.1% (1,000 ppm). Gases, carbon and sulfur are not included in the analysis but can possibly be determined if needed.

CERTIFICATE OF ANALYSIS AND MSDS

All items are shipped with an analysis certificate. The analysis is specific to the actual batch of material being sent and not a "typical analysis", unless specifically stated.

All dangerous materials are shipped are attached by a Material Safety Data Sheet (MSDS).

CUSTOM MANUFACTURING

The pellets sizes and purity listed are those most commonly used and called as. However Neyco can offer nearly any range of dimensions desired, with purity that needed on request.



Vacuum Deposition Grade Pellets

AI

13

ALUMINUM Base

CHEMICAL	FORMULA	DESCRIPTION	PURITY*
Aluminum	Al	3-6 mm 3 mm Ø x 3 mm / 6 mm Ø x 6 mm	99.99 to 99.999
Aluminum Antimonide	AlSb	3-6 mm	99.99
Aluminum Copper (98/2 wt%), (95/5 wt%), (99/1 wt%)	Al-Cu	3 mm Ø x 3 mm / 6 mm Ø x 6 mm	99.99 to 99.999
Aluminum Fluoride	AlF ₃	1-4 mm / 3-6 mm	99.5 to 99.99
Aluminum Iodide	AlI ₃	3-6 mm	99.999
Aluminum Magnesium (97.5/2.5 mol%)	Al-Mg	3-6 mm	99.99
Aluminum Nitride	AlN	1-4 mm / 3-6 mm	99.5 to 99.9
Aluminum Oxide	Al ₂ O ₃	1-3 mm 2-12 mm 10 mm Ø x 10 mm / 10-12 mm Ø x 4-5 mm	99.8 to 99.99
Aluminum Selenide	Al ₂ Se ₃	3-6 mm / 3-12 mm	99.5 to 99.999
Aluminum Silicon (99/1 wt%)	Al-Si	6 mm Ø x 6 mm	99.999
Aluminum Sulfide	Al ₂ S ₃	3-6 mm	98 to 99.9
Aluminum Telluride	Al ₂ Te ₃	3-6 mm	99.5
Aluminum Titanium Oxide (85/15 mol%)	Al ₂ O ₃ -TiO ₂	1-3 mm	99.99

*Purity based on metallic impurities - vacuum deposition grade.

Sb

51

ANTIMONY Base

CHEMICAL	FORMULA	DESCRIPTION	PURITY*
Antimony	Sb	3-6 mm / 3-20 mm	99.5 to 99.9999
Antimony Arsenide	Sb ₃ As	3-6 mm / 5-50 mm	99.999
Antimony Iodide	SbI ₃	1-12 mm	99.999
Antimony Oxide	Sb ₂ O ₃	3-12 mm	99.9
Antimony Selenide	Sb ₂ Se ₃	3-6 mm / 3-12 mm	99 to 99.999
Antimony Selium	SbSe	3-12 mm	99.999
Antimony Sulfide	Sb ₂ S ₃	3-6 mm / 3-12 mm	99.99 to 99.999
Antimony Telluride	Sb ₂ Te ₃	3-6 mm / 3-12 mm	99 to 99.999

As

33

ARSENIC Base

CHEMICAL	FORMULA	DESCRIPTION	PURITY*
Arsenic	As	3-12 mm / 4-20 mm	99 to 99.99999
Arsenic Oxide	As ₂ O ₅	3-12 mm	99.9 to 99.999
Arsenic Selenide	As ₂ Se ₃	1-6 mm	99 to 99.999
Arsenic Sulfide	As ₂ S ₃	3-12 mm / 1-6 mm	99.9 to 99.999
Arsenic Telluride	As ₂ Te ₃	3-12 mm	99 to 99.999

Ba

56

BARIUM Base

CHEMICAL	FORMULA	DESCRIPTION	PURITY*
Barium	Ba	0.2-3 mm	98
Barium	Ba	3-25 mm	99.7 to 99.9
Barium Aluminide	BaAl ₄	3-6 mm	99.5
Barium Antimonide	Ba ₃ Sb ₂	3-6 mm	99.5
Barium Arsenide	Ba ₃ As ₂	3-6 mm	99.5
Barium Fluoride	BaF ₂	3-6 mm	99.9 to 99.99
Barium Fluoride	BaF ₂	3-12 mm	99.995
Barium Hafnium Oxide	BaHfO ₃	3-6 mm	99.995
Barium Silicide	BaSi ₂	3-6 mm	98
Barium Titanate	BaTiO ₃	3-12 mm	99.95 to 99.99
Barium Zirconate	BaZrO ₃	1-4 mm	99.99

*Purity based on metallic impurities - vacuum deposition grade.

Bi

83

BISMUTH Base

CHEMICAL	FORMULA	DESCRIPTION	PURITY*
Bismuth	Bi	1-12 mm / 2-5 mm	99.999 to 99.9999
Bismuth Antimonide	BiSb	3-6 mm	99.99
Bismuth Oxide	Bi ₂ O ₃	3-12 mm	99.9 to 99.99
Bismuth Selenide	Bi ₂ Se ₃	1-6 mm	99 to 99.999
Bismuth Sulfide	Bi ₂ S ₃	3-6 mm	99.999
Bismuth Telluride	Bi ₂ Te ₃	1-6 mm	99 to 99.999

B

5

BORON Base

CHEMICAL	FORMULA	DESCRIPTION	PURITY*
Boron	B	3-8 mm	99.5
Boron Carbide	B ₄ C	2-3 mm / 3-6 mm	99.5
Boron Nitride	BN	3-6 mm	99.5
Boron Oxide	B ₂ O ₃	3-12 mm	99.9995

Cd

48

CADMIUM Base

CHEMICAL	FORMULA	DESCRIPTION	PURITY*
Cadmium	Cd	1-3 mm / 3-20 mm	99.999
Cadmium Antimonide	Cd ₃ Sb ₂	3-6 mm	99.999
Cadmium Arsenide	Cd ₃ As ₂	3-6 mm / 3-50 mm	99 to 99.999
Cadmium Fluoride	CdF ₂	3-6 mm	99.9
Cadmium Oxide	CdO	1-4 mm	99.99
Cadmium Phosphide	Cd ₃ P ₂	3-6 mm	99.999
Cadmium Selenide	CdSe	3-12 mm	99.99 to 99.999
Cadmium Stannate	Cd ₂ SnO ₄	3-6 mm	99.99
Cadmium Sulfide	CdS	3-6 mm / 3-12 mm	99.99 to 99.999
Cadmium Telluride	CdTe	3-6 mm / 3-12 mm	99 to 99.999
Cadmium Zinc Telluride	CdZnTe	3-6 mm	99.999
Cadmium Tungstate	CdWO ₄	1-4 mm	99.95

*Purity based on metallic impurities - vacuum deposition grade.

Ca

20

CALCIUM Base

CHEMICAL	FORMULA	DESCRIPTION	PURITY*
Calcium	Ca	0.2-2 mm / 3-12 mm	99.5 to 99.99
Calcium Fluoride	CaF ₂	1-4 mm	99.95 to 99.99
Calcium Hydride	CaH ₂	2 mm and smaller	98
Calcium Nitride	Ca ₃ N ₂	3-12 mm	99
Calcium Oxide	CaO	3-6 mm	99.95
Calcium Silicate	CaSiO ₃	3-12 mm	99
Calcium Silicide	CaSi	3 mm and smaller	99.5
Calcium Silicide	CaSi ₂	3 mm and smaller	99.5

Ce

58

CERIUM Base

CHEMICAL	FORMULA	DESCRIPTION	PURITY*
Cerium	Ce	6 mm Ø x 6 mm / 13-12 mm	99.9 to 99.95
Cerium Carbide	CeC ₂	3-6 mm	99.5
Cerium Fluoride	CeF ₃	3-6 mm / 3-12 mm	99.9 to 99.995
Cerium Oxide	CeO ₂	3-6 mm / 3-12 mm	99.99 to 99.95
Cerium Silicide	CeSi ₂	3-6 mm / 3-15 mm	99.9

Cr

24

CHROMIUM Base

CHEMICAL	FORMULA	DESCRIPTION	PURITY*
Chromium	Cr	1-3 mm / 3-6 mm 3 mm Ø x 3 mm / 6 mm Ø x 6 mm	99.2 to 99.99
Chromium Oxide	Cr ₂ O ₃	1-4 mm / 3-6 mm	99.7 to 99.9
Chromium Silicon Monoxide (70/30 wt%), (60/40 wt%), (50/50 wt%)	Cr-SiO	1-3 mm / 3-6 mm	99.9 to 99.95

*Purity based on metallic impurities - vacuum deposition grade.

Co
27

COBALT Base

CHEMICAL	FORMULA	DESCRIPTION	PURITY*
Cobalt	Co	1-5 mm / 3-6 mm 6 mm Ø x 6 mm	99.95 to 99.98+
Cobalt Oxide	Co ₃ O ₄	1-4 mm	99.9
Cobalt Palladium	CoPd	1-4 mm	99.95
Cobalt Samarium (80/20 wt%)	Co-Sm	3-12 mm	99.95
Cobalt Selenide	CoSe	3-6 mm / 3-12 mm	99.5
Cobalt Telluride	CoTe	3-6 mm	99.5

*Purity based on metallic impurities - vacuum deposition grade.



Cu
29**COPPER Base**

CHEMICAL	FORMULA	DESCRIPTION	PURITY*
Copper	Cu	3 mm Ø x 3 mm / 6 mm Ø x 6 mm	99.99 to 99.999
Copper Aluminum Oxide	CuAlO ₂	1-4 mm / 3-6 mm	99.95
Copper Boride (97.46/2.54 wt%), (99.5/0.5 wt%)	Cu-B	3-6 mm	99.99
Copper Gallium	CuGa	3-12 mm	99.99
Copper Germanide	CuGe	3-6 mm	99.99
Copper Germanide Selenide	CuGeSe ₂	3-6 mm	99.99
Copper Indium Selenide	CuInSe ₂	3-6 mm	99.999
Copper Indium Sulfide	CuInS ₂	3-6 mm	99.999
Copper Indium Telluride	CuInTe ₂	3-6 mm	99.999
Copper Oxide	CuO / Cu ₂ O	3-12 mm	99.9
Copper Selenide	CuSe	3-6 mm	99.999
Copper Selenide	Cu ₂ Se	3-6 mm	99.5
Copper Silicide	Cu ₃ Si	1-6 mm	99.5 to 99.99
Copper Sulfate	CuSO _{4.5} -H ₂ O	1-3 mm	99.95
Copper Telluride	Cu ₂ Te	3-6 mm	99.5 to 99.999
Copper Titanium	CuTi	3-12 mm	99.95
Copper Titanium Selenide	CuTiSe ₂	3-6 mm	99.999
Copper Titanium Telluride	CuTiTe ₂	3-6 mm	99.999
Copper Zirconium	CuZr	1-4 mm	99.95

Dy
66**DYSPROSIUM Base**

CHEMICAL	FORMULA	DESCRIPTION	PURITY*
Dysprosium	Dy	3-12 mm / 6-12 mm	99.9 to 99.95
Dysprosium Fluoride	DyF ₃	1-4 mm/3-6 mm/6-12 mm	99.9 to 99.995
Dysprosium Fluoride	DyF ₃	3-12 mm	99.9
Dysprosium Nickelide	DyNi ₂	3-6 mm	99.9
Dysprosium Oxide	Dy ₂ O ₃	3-6 mm/3-12 mm	99.9

*Purity based on metallic impurities - vacuum deposition grade.

Er

68

ERBIUM Base

CHEMICAL	FORMULA	DESCRIPTION	PURITY*
Erbium	Er	3-6 mm / 2-12 mm	99.9 to 99.95
Erbium Fluoride	ErF ₃	1-4 mm / 3-6 mm / 3-12 mm	99.9 to 99.995
Erbium Oxide	Er ₂ O ₃	3-12 mm	99.9 to 99.99
Erbium Silicide	Er ₃ Si ₅	3-6 mm	99.9

Eu

63

EUROPIUM Base

CHEMICAL	FORMULA	DESCRIPTION	PURITY*
Europium	Eu	3-12 mm	99.9
Europium Fluoride	EuF ₃	3-6 mm	99.9
Europium Oxide	Eu ₂ O ₃	3-6 mm / 3-12 mm	99.9 to 99.99
Europium Silicide	EuSi ₂	3-6 mm	99.5 to 99.9

Gd

64

GADOLINIUM Base

CHEMICAL	FORMULA	DESCRIPTION	PURITY*
Gadolinium	Gd	2-12 mm / 3-6 mm	99.9 to 99.95
Gadolinium Fluoride	GdF ₃	1-4 mm / 3-6 mm	99.9 to 99.995
Gadolinium Gallium Oxide (GGG)	Gd ₃ Ga ₅ O ₁₂	3-12 mm	99.9
Gadolinium Oxide	Gd ₂ O ₃	3-6 mm / 3-12 mm	99.9 to 99.995
Gadolinium Silicide	GdSi ₂	3-6 mm	99.9

*Purity based on metallic impurities - vacuum deposition grade.

Ga

31

GALLIUM Base

CHEMICAL	FORMULA	DESCRIPTION	PURITY*
Gallium	Ga	3-6 mm 30 mm Ø x 26 mm / 10 mm Ø x 24 mm / 9 mm Ø x 67 mm / 13 mm Ø x 63 mm	99.99 to 99.999999
Gallium Antimonide	GaSb	3-6 mm	99.99 to 99.999
Gallium Arsenide	GaAs	3-6 mm / 1-15 mm	99.999
Gallium Oxide	Ga ₂ O ₃	3-6 mm / 3-12 mm	99.995 to 99.999
Gallium Indium Zinc Oxide (1/1/1 mol%)	Ga ₂ O ₃ -In ₂ O ₃ -ZnO	3-6 mm	99.99
Gallium Phosphoride	GaP	3-6 mm	99.999
Gallium Selenide	Ga ₂ Se ₃	3-6 mm / 3-12 mm	99.99 to 99.999
Gallium Sulfide	GaS	3-6 mm	99.95 to 99.999
Gallium Telluride	GaTe	3-6 mm	99.999
Gallium Telluride	Ga ₂ Te ₃	3-6 mm	99.999

Ge

32

GERMANIUM Base

CHEMICAL	FORMULA	DESCRIPTION	PURITY*
Germanium	Ge	1-4 mm / 3-6 mm / 3-12 mm	99.999 to 99.9999
Germanium Antimonide	GeSb	3-6 mm	99.999
Germanium Antimony Telluride (GST)	GeSbTe	3-6 mm	99.99 to 99.999
Germanium Arsenide	GeAs	3-12 mm	99.99
Germanium Oxide	GeO ₂	3-12 mm	99.999
Germanium Selenide	GeSe / GeSe ₂	3-6 mm	99.99 to 99.999
Germanium Sulfide	GeS / GeS ₂	3-6 mm	99.999
Germanium Telluride	GeTe	3-6 mm	99.9999

Au

79

GOLD Base

CHEMICAL	FORMULA	DESCRIPTION	PURITY*
Gold	Au	3 mm Ø x 3 mm / 3 mm Ø x 6 mm 3-6 mm	99.99 to 99.999
Gold Germanium (88/12 wt%), (95/5 wt%)	Au-Ge	3-6 mm	99.99 to 99.999
Gold Palladium (60/40 wt%)	Au-Pd	3-6 mm	99.99
Gold Tin (80/20 at%)	Au-Sn	1-4 mm / 3-6 mm	99.99 to 99.999
Gold Zinc (88/12 wt%) (95/5 wt%)	Au-Zn	1-4 mm / 3-6 mm	99.99 to 99.999

*Purity based on metallic impurities - vacuum deposition grade.

C

6

GRAPHITE Base

CHEMICAL	FORMULA	DESCRIPTION	PURITY*
Graphite	C	1-4 mm / 3-15 mm	99.99 to 99.999

Hf

72

HAFNIUM Base

CHEMICAL	FORMULA	DESCRIPTION	PURITY*
Hafnium	Hf	3 mm Ø x 3mm / 6 mm Ø x 6 mm 3-12 mm	99.9 to 99.95
Hafnium Carbide	HfC	3-12 mm	99.9
Hafnium Fluoride	HfF ₄	1-4 mm / 3-6 mm	99.9 to 99.95
Hafnium Nitride	HfN	1-4 mm	99.5
Hafnium Oxide	HfO ₂	1-4 mm / 3-6 mm 10 mm Ø x 4 mm / 17 mm Ø x 5 mm	99.9 to 99.99
Hafnium Oxide Neodymium Oxide	HfO ₂ -Nd ₂ O ₃	1-4 mm	99.995
Hafnium Oxide Scandium Oxide	HfO ₂ -Sc ₂ O ₃	1-4 mm	99.995
Hafnium Oxide Titanium Dioxide	HfO ₂ -TiO ₂	10 mm Ø x 10 mm	99.95
Hafnium Oxide Yttrium Oxide	HfO ₂ -Y ₂ O ₃	1-4 mm	99.95

Ho

67

HOLMIUM Base

CHEMICAL	FORMULA	DESCRIPTION	PURITY*
Holmium	Ho	3-6 mm / 3-12 mm	99.9 to 99.95
Holmium Fluoride	HoF ₃	3-6 mm	99.9 to 99.995
Holmium Oxide	Ho ₂ O ₃	3-12 mm	99.9
Holmium Silicide	HoSi ₂	3-6 mm	99.9

*Purity based on metallic impurities - vacuum deposition grade.

In

49

INDIUM Base

CHEMICAL	FORMULA	DESCRIPTION	PURITY*
Indium	In	3 mm Ø x 3 mm / 6 mm Ø x 6 mm 1-3 mm	99.99 to 99.9999
Indium Antimonide	InSb	3-6 mm	99.99 to 99.999
Indium Arsenide	InAs	3-6 mm	99.99 to 99.999
Indium Bismuth	InBi	3-6 mm	99.999
Indium Fluoride	InF ₃	3-6 mm	99.995
Indium Gallium Zinc Oxide (IGZO)	InGaZnO	3-6 mm	99.99
Indium Oxide	In ₂ O ₃	3-6 mm / 3-12 mm	99.99 to 99.999
Indium Phosphoride	InP	3-6 mm	99.999
Indium Selenide	InSe / In ₂ Se ₃	3-6 mm	99.99 to 99.999
Indium Sulfide	In ₂ S ₃	3-6 mm	99.99
Indium Telluride	In ₂ Te ₃	3-6 mm	99.999
Indium Tin (90/10 wt%)	In-Sn	3-6 mm	99.99
Indium Tin Oxide, ITO (90/10 wt%), (91/9 wt%)	In ₂ O ₃ -SnO ₂	1-4 mm / 3-6 mm / 3-12 mm	99.99 to 99.998

Ir

77

IRIDIUM Base

CHEMICAL	FORMULA	DESCRIPTION	PURITY*
Iridium	Ir	1-4 mm / 3-6 mm	99.95 to 99.98
Iridium Oxide	Ir ₂ O ₃ / IrO ₂	1-4 mm	99.95

Fe

26

IRON Base

CHEMICAL	FORMULA	DESCRIPTION	PURITY*
Iron	Fe	3 mm Ø x 3 mm / 6 mm Ø x 6 mm 1-3 mm / 3-6 mm	99.95 to 99.995
Iron Antimonide	FeSb	3-6 mm	99.5 to 99.9
Iron Arsenide	FeAs / FeAs ₂ / Fe ₂ As	3-6 mm	99.5 to 99.9
Iron Nickel Boride	FeNiB	3-6 mm	99.95
Iron Oxide	Fe ₂ O ₃ / Fe ₃ O ₄	1-4 mm / 3-12 mm	99.9 to 99.95
Iron Telluride	FeTe / FeTe ₂	3-6 mm	99.5

*Purity based on metallic impurities - vacuum deposition grade.

La

57

LANTHANUM Base

CHEMICAL	FORMULA	DESCRIPTION	PURITY*
Lanthanum	La	1-4 mm / 3-12 mm	99.9 to 99.95
Lanthanum Aluminum Oxide	LaAlO ₃	1-4 mm / 3-6 mm	99.9
Lanthanum Boride	LaB ₆	3-6 mm / 6-12 mm	99.5
Lanthanum Carbide	LaC ₂	3-12 mm	99.9
Lanthanum Fluoride	LaF ₃	1-4 mm / 3-6 mm / 8-10 mm / 8 mm Ø x 5-7 mm	99.9 to 99.995
Lanthanum Nickel	LaNi ₅	3-12 mm	99.9
Lanthanum Oxide	La ₂ O ₃	3-12 mm	99.9
Lanthanum Silicide	LaSi ₂	3-6 mm	99.9
Lanthanum Titanium Oxide	LaTiO ₃	1-4 mm	99.9

Pb

82

LEAD Base

CHEMICAL	FORMULA	DESCRIPTION	PURITY*
Lead	Pb	1-2 mm / 3 mm	99.9 to 99.9999
Lead Chloride	PbCl ₂	1-2 mm / 0.8-3.4 mm	99.999
Lead Fluoride	PbF ₂	1-3 mm / 3-6 mm	99.9 to 99.99
Lead Selenide	PbSe	3-6 mm	99 to 99.999
Lead Telluride	PbTe	1-3 mm / 3-6 mm	99.995 to 99.999

Li

3

LITHIUM Base

CHEMICAL	FORMULA	DESCRIPTION	PURITY*
Lithium	Li	2.5 mm	99
Lithium Fluoride	LiF	3-6 mm	99.9 to 99.995
Lithium Niobate	LiNbO ₃	3-12 mm	99.99
Lithium Silicide	LiSi ₂	3-6 mm	99.9

*Purity based on metallic impurities - vacuum deposition grade.

Lu

71

LUTETIUM Base

CHEMICAL	FORMULA	DESCRIPTION	PURITY*
Lutetium	Lu	3-12 mm	99.9 to 99.99
Lutetium Fluoride	LuF ₃	3-6 mm	99.9 to 99.99
Lutetium Oxide	Lu ₂ O ₃	3-6 mm / 3-12 mm	99.9 to 99.99
Lutetium Silicide	LuSi ₂	3-6 mm	99.9

Mg

12

MAGNESIUM Base

CHEMICAL	FORMULA	DESCRIPTION	PURITY*
Magnesium	Mg	4 mm Ø x 4 mm / 1-5 mm	99.9 to 99.99
Magnesium Antimonide	Mg ₃ Sb ₂	3-6 mm	99.5
Magnesium Aluminum Oxide	MgAl ₂ O ₄	3-12 mm	99.9 to 99.99
Magnesium Arsenide	Mg ₃ As ₂	3-6 mm	99.5
Magnesium Bismuth	Mg ₃ Bi ₂	3-6 mm / 1-4 mm	99.99
Magnesium Cerium Fluoride	MgF ₂ -CeF ₃	1-4 mm	99.995
Magnesium Fluoride	MgF ₂	0.7-1.5 mm / 3-6 mm	99.9 to 99.995
Magnesium Germanide	Mg ₂ Ge	3-6 mm	99.99
Magnesium Neodymium Fluoride	MgF ₂ -NdF ₃	3-6 mm	99.995
Magnesium Oxide	MgO	1-3 mm / 3-6 mm / 3-12 mm	99.5 to 99.999
Magnesium Plumbide	Mg ₂ Pb	3-6 mm	99.99
Magnesium Silicide	Mg ₂ Si	3-12 mm	99.5 to 99.99

Mn

25

MANGANESE Base

CHEMICAL	FORMULA	DESCRIPTION	PURITY*
Manganese	Mn	1-4 mm / 3-6 mm / 1-12 mm	99.5 to 99.99
Manganese Aluminide	MnAl ₃	3-6 mm / < 10 mm	99.5
Manganese Antimonide	MnSb	3-6 mm	99.5
Manganese Antimonide	Mn ₂ Sb	3-6 mm	99.5 to 99.95
Manganese Carbide	Mn ₃ C-Mn ₅ C ₂	3-6 mm	99.5
Manganese Telluride	MnTe ₂	3-6 mm	99.9 to 99.99

*Purity based on metallic impurities - vacuum deposition grade.

Mo
42

MOLYBDENUM Base

CHEMICAL	FORMULA	DESCRIPTION	PURITY*
Molybdenum	Mo	3 mm Ø x 3 mm / 6mm Ø x 6 mm	99.95
Molybdenum Oxide	MoO ₃	3-6 mm	99.99
Molybdenum Silice	Mo ₅ Si ₃	3-12 mm	99.5
Molybdenum Sulfide	MoS ₂	3-6 mm	99.9
Molybdenum Telluride	MoTe ₂	3-12 mm	99.9

Nd
60

NEODYMIUM Base

CHEMICAL	FORMULA	DESCRIPTION	PURITY*
Neodymium	Nd	3-12 mm	99.9 to 99.99
Neodymium Fluoride	NdF ₃	3-6 mm / 3-12 mm	99.9 to 99.995
Neodymium Oxide	Nd ₂ O ₃	3-12 mm	99.9 to 99.95
Neodymium Silicide	NdSi ₂	3-6 mm	99.9

*Purity based on metallic impurities - vacuum deposition grade.



NICKEL Base

CHEMICAL	FORMULA	DESCRIPTION	PURITY*
Nickel	Ni	3 mm Ø x 3 mm / 6 mm Ø x 6 mm 6-12 mm	99.9 to 99.995
Nickel Antimonide	NiSb / Ni ₃ Sb	3-6 mm	99.5
Nickel Arsenide	NiAs / NiAs ₂	3-6 mm	99.5 to 99.995
Nickel Bismuthide	NiBi	3-6 mm	99.5
Nickel Chromium (80/20 wt%), (70/30 wt%), (60/40 wt%), (50/50 at %)	Ni-Cr / NiCr	3 mm Ø x 3 mm / 6 mm Ø x 6 mm	98 to 99.95
Nickel Chromium Iron (72/14/14 wt%)	Ni-Cr-Fe	6 mm Ø x 12 mm	99
Nickel Iron (80/20 wt%)	Ni-Fe	6.35 mm Ø x 6.35 mm	99.95
Nickel Oxide	NiO	3-6 mm / 3-12 mm	99.9 to 99.995
Nickel Palladium (50/50 mol%) (70/30 mol%)	Ni-Pd	3-6 mm	99.99
Nickel Selenide	NiSe	3-6 mm	99.9 to 99.95
Nickel Silicon (65/35 mol%)	Ni-Si	3-6 mm	99.99
Nickel Telluride	NiTe	3-6 mm	99.9
Nickel Zirconium	NiZr	1-4 mm / 3-6 mm	99.5 to 99.9

*Purity based on metallic impurities - vacuum deposition grade.



Nb

41

NIOBIUM Base

CHEMICAL	FORMULA	DESCRIPTION	PURITY*
Niobium	Nb	3 mm Ø x 3 mm / 6 mm Ø x 6 mm	99.95
Niobium Carbide	NbC	3-12 mm	99.5
Niobium Fluoride	NbF ₅	1-4 mm	99.99
Niobium Nitride	NbN	3-12 mm	99.5
Niobium Oxide	Nb ₂ O ₅	1-3 mm / 3-12 mm	99.9 to 99.995

Pd

46

PALLADIUM Base

CHEMICAL	FORMULA	DESCRIPTION	PURITY*
Palladium	Pd	3-6 mm / 3 mm Ø x 6 mm	99.95

P

15

PHOSPHORUS Base

CHEMICAL	FORMULA	DESCRIPTION	PURITY*
Phosphorus	P	3-6 mm	99.999+

Pt

78

PLATINUM Base

CHEMICAL	FORMULA	DESCRIPTION	PURITY*
Platinum	Pt	3-6 mm / 3 mm Ø x 6 mm	99.95 to 99.99

*Purity based on metallic impurities - vacuum deposition grade.

K

19

POTASSIUM Base

CHEMICAL	FORMULA	DESCRIPTION	PURITY*
Potassium	K	irregular	99.95
Potassium Chloride	KCl	5-10 mm	99.99
Potassium Fluoride	KF·2H ₂ O	3-6 mm	99.95 to 99.99
Potassium Iodide	KI	3-6 mm	99.98

Pr

59

PRASEODYMIUM Base

CHEMICAL	FORMULA	DESCRIPTION	PURITY*
Praseodymium	Pr	3-6 mm / 3-12 mm	99.9 to 99.95
Praseodymium Fluoride	PrF ₃	3-6 mm	99.9
Praseodymium Oxide	Pr ₂ O ₃ / Pr ₆ O ₁₁	1-4 mm / 3-12 mm	99.9 to 99.95
Praseodymium Silicide	PrSi ₂	3-6 mm	99.9

Re

75

RHENIUM Base

CHEMICAL	FORMULA	DESCRIPTION	PURITY*
Rhenium	Re	3-6 mm / 3-12 mm	99.95 to 99.99

Rh

45

RHODIUM Base

CHEMICAL	FORMULA	DESCRIPTION	PURITY*
Rhodium	Rh	1-4 mm	99.95

*Purity based on metallic impurities - vacuum deposition grade.

Rb

37

RUBIDIUM Base

CHEMICAL	FORMULA	DESCRIPTION	PURITY*
Rubidium	Rb	ingots	99.8 to 99.99

Ru

44

RUTHENIUM Base

CHEMICAL	FORMULA	DESCRIPTION	PURITY*
Ruthenium	Ru	3-6 mm / 3-12 mm	99.95
Ruthenium Oxide	RuO ₂	3-6 mm / 3-12 mm	99.95 to 99.99

Sm

62

SAMARIUM Base

CHEMICAL	FORMULA	DESCRIPTION	PURITY*
Samarium	Sm	1-3 mm / 3-12 mm	99.9 to 99.95
Samarium Fluoride	SmF ₃	3-6 mm	99.9
Samarium Oxide	Sm ₂ O ₃	3-12 mm	99.9 to 99.99

Sc

21

SCANDIUM Base

CHEMICAL	FORMULA	DESCRIPTION	PURITY*
Scandium	Sc	3-12 mm / 2-50 mm	99.9 to 99.999
Scandium Fluoride	ScF ₃	3-12 mm	99.9
Scandium Oxide	Sc ₂ O ₃	1-4 mm / 3-6 mm	99.99 to 99.999

*Purity based on metallic impurities - vacuum deposition grade.

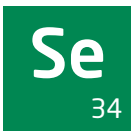

SELENIUM Base

CHEMICAL	FORMULA	DESCRIPTION	PURITY*
Selenium	Se	1-4 mm / 3 mm / 10-25 mm	99.99 to 99.999



SILICON Base

CHEMICAL	FORMULA	DESCRIPTION	PURITY*
Silicon	Si	1-4 mm / 3-6 mm / 3-20 mm	99.96 to 99.9999
Silicon Aluminum (92/8 mol%)	Si-Al	10 mm Ø x 10 mm	99.999
Silicon Carbide	SiC	0.2-1 mm	99.5
Silicon Nitride	Si ₃ N ₄	1-4 mm / 3-6 mm	99.5 to 99.9
Silicon Dioxide	SiO ₂	1-3 mm / 1-4 mm	99.95 to 99.995
Silicon Monoxide	SiO	0.2-0.5 mm / 3-12 mm / 6-12 mm	99.9 to 99.99
Silicon Sulfide	SiS ₂	25 mm and smaller	95

*Purity based on metallic impurities - vacuum deposition grade.



Ag
47**SILVER Base**

CHEMICAL	FORMULA	DESCRIPTION	PURITY*
Silver	Ag	2-6 mm / 3 mm Ø x 10 mm	99.99 to 99.999
Silver Calcium (80/20 mol%), (50/50 mol%)	Ag-Ca	3-6 mm	99
Silver Sulfide	Ag ₂ S	3-6 mm	99.999
Silver Aluminum (95/5 mol%)	Ag-Al	1-4 mm	99.99
Silver Chromium (95/5 mol%)	Ag-Cr	3-6 mm	99.99
Silver Copper (90/10 mol%)	Ag-Cu	3-6 mm	99.99
Silver Fluoride	AgF	3-6 mm	99.99
Silver Gallium Selenide	AgGaSe ₂	3-6 mm	99.999
Silver Gallium Telluride	AgGaTe ₂	3-6 mm	99.999
Silver Indium Sulfide	AgInS ₂	3-6 mm	99.999
Silver Indium Selenide	AgInSe ₂	3-6 mm	99.999
Silver Indium Telluride	AgInTe ₂	3-6 mm	99.999
Silver Titanium Selenide	AgTiSe ₂	3-6 mm	99.999
Silver Titanium Telluride	AgTiTe ₂	3-6 mm	99.999

Na
11**SODIUM Base**

CHEMICAL	FORMULA	DESCRIPTION	PURITY*
Sodium	Na	3-12 mm	99.95
Sodium Aluminum Fluoride	Na ₃ AlF ₆ / Na ₅ Al ₃ F ₁₄	1-4 mm / 3-6 mm / 8-10 mm	99.5 to 99.9
Sodium Fluoride	NaF	0.1-1 mm / 3-6 mm	99.9 to 99.95

Sr
38**STRONTIUM Base**

CHEMICAL	FORMULA	DESCRIPTION	PURITY*
Strontium	Sr	1-12 mm / 3-6 mm	99.8 to 99.95
Strontium Fluoride	SrF ₂	3-6 mm / 3-12 mm	99.9 to 99.9
Strontium Copper Oxide, SCO	SrCu ₂ O ₂	3-6 mm	99.9
Strontium Silicide	SrSi ₂	3-6 mm	99.5
Strontium Titanate	SrTiO ₃	3-6 mm	99.95

*Purity based on metallic impurities - vacuum deposition grade.

S

16

SULFUR Base

CHEMICAL	FORMULA	DESCRIPTION	PURITY*
Sulfur	S	3-6 mm	99.999

Ta

73

TANTALUM Base

CHEMICAL	FORMULA	DESCRIPTION	PURITY*
Tantalum	Ta	3-12 mm 3 mm Ø x 3 mm / 6 mm Ø x 6 mm	99.95
Tantalum Oxide	Ta ₂ O ₅	1-4 mm 8 mm Ø x 5 mm	99.95 to 99.995
Tantalum Carbide	TaC	3-12 mm	99.5
Tantalum Nitride	TaN	3 mm Ø x 6 mm	99.95

Te

52

TELLURIUM Base

CHEMICAL	FORMULA	DESCRIPTION	PURITY*
Tellurium	Te	1-6 mm / 3-12 mm	99.99 to 99.9999

Tb

65

TERBIUM Base

CHEMICAL	FORMULA	DESCRIPTION	PURITY*
Terbium	Tb	1-4 mm / 2-12 mm / 3-12 mm	99.9 to 99.95
Terbium Fluoride	TbF ₃	3-12 mm	99.9
Terbium Oxide	Tb ₄ O ₇	3-6 mm / 3-12 mm	99.9
Terbium Silicide	TbSi ₂	3-6 mm	99.9

*Purity based on metallic impurities - vacuum deposition grade.

Tm
69

THULIUM Base

CHEMICAL	FORMULA	DESCRIPTION	PURITY*
Thulium	Tm	3-6 mm / 3-12 mm	99.9 to 99.95
Thulium Fluoride	TmF ₃	3-6 mm / 3-12 mm	99.9 to 99.99
Thulium Oxide	Tm ₂ O ₃	3-12 mm	99.9
Thulium Silicide	Tm ₃ Si ₅	3-6 mm	99.9

Sn
50

TIN Base

CHEMICAL	FORMULA	DESCRIPTION	PURITY*
Tin	Sn	1-3 mm 3 mm Ø x 3 mm	99.9 to 99.9999
Tin Antimonide	SnSb	3-6 mm	99.999
Tin Arsenide	SnAs	3-6 mm	99.999
Tin Oxide	SnO ₂	0.5-1 mm / 3-12 mm	99.9 to 99.995
Tin Oxide Antimony Oxide	SnO ₂ -Sb ₂ O ₃	3-6 mm	99.9
Tin Selenide	SnSe	3-12 mm	99.999
Tin Silver (96.5/3.5 mol%)	Sn-Ag	3-6 mm	99.99
Tin Sulfide	SnS / SnS ₂	3-12 mm	99.99
Tin Telluride	SnTe	1-6 mm / 3-6 mm / 3-12 mm	99.8 to 99.999

Ti
22

TITANIUM Base

CHEMICAL	FORMULA	DESCRIPTION	PURITY*
Titanium	Ti	0.8-12.7 mm 3 mm Ø x 3 mm / 6 mm Ø x 6 mm	99.8 to 99.998
Titanium Aluminide	TiAl ₃	3-6 mm	99.5
Titanium Monoxide	TiO	1-4 mm / 3-6 mm / 3-12 mm 9 mm Ø x 6 mm	99.9
Titanium Oxide	TiO ₂	1-4 mm / 3-6 mm / 3-12 mm / 10-12 mm Ø x 4-5 mm / 18 mm Ø x 12 mm	99.99
Titanium Oxide	Ti ₂ O ₃	1-4 mm / 8-9 mm Ø x 6-7 mm	99.9 / 99.99
Titanium Oxide	Ti ₃ O ₅	1-4 mm / 0.5-2 mm / 0.3-1 mm / 8-9 mm Ø x 7-9 mm	99.99
Titanium Oxide	Ti ₅ O ₇	1-4 mm	99.99

*Purity based on metallic impurities - vacuum deposition grade.

W

74

TUNGSTEN Base

CHEMICAL	FORMULA	DESCRIPTION	PURITY*
Tungsten	W	1-6 mm / 3-6 mm / 3 mm Ø x 3 mm / 6 mm Ø x 6 mm / 12 mm Ø x 6 mm	99.95
Tungsten Carbide	WC	3-12 mm	99.5
Tungsten Oxide	WO ₃	1-4 mm / 3-12 mm	99.99
Tungsten Titanium (90/10 mol%)	W-Ti	3-6 mm / 3-12 mm	99.9 to 99.99

V

23

VANADIUM Base

CHEMICAL	FORMULA	DESCRIPTION	PURITY*
Vanadium	V	1-6 mm / 3-12 mm 6 mm Ø x 6 mm	99.9 to 99.95
Vanadium Carbide	VC	3-12 mm	99.5
Vanadium Nitride	VN	3-12 mm	99.5
Vanadium Oxide	V ₂ O ₅	3-6 mm	99.5 to 99.95

Yb

70

YTTERBIUM Base

CHEMICAL	FORMULA	DESCRIPTION	PURITY*
Ytterbium	Yb	1-4 mm / 3-6 mm / 3-12 mm	99.9 to 99.99
Ytterbium Fluoride	YbF ₃	3-12 mm / 8-10 mm	99.9 to 99.995
Ytterbium Oxide	Yb ₂ O ₃	3-12 mm	99.9 to 99.995
Ytterbium Silicide	Yb ₃ Si ₅	3-6 mm	99.9

Y

39

YTTRIUM Base

CHEMICAL	FORMULA	DESCRIPTION	PURITY*
Yttrium	Y	3-12 mm / 6-12 mm	99.9 to 99.99
Yttrium Aluminum Oxide (YAG)	Y ₃ Al ₅ O ₁₂	3-6 mm / 3-12 mm	99.99
Yttrium Carbide	YC ₂	12 mm	99.5

*Purity based on metallic impurities - vacuum deposition grade.

CHEMICAL	FORMULA	DESCRIPTION	PURITY*
Yttrium Ditanate	$Y_2Ti_2O_7$	10 mm \varnothing x 10 mm	99.9
Yttrium Fluoride	YF_3	3-6 mm / 3-12 mm 10 mm \varnothing x 10 mm	99.9 to 99.998
Yttrium Oxide	Y_2O_3	1-4 mm / 10 mm \varnothing x 10 mm	99.9 to 99.99
Yttrium Silicide	Y_3Si_5	3-6 mm	99.9

Zn
30

ZINC Base

CHEMICAL	FORMULA	DESCRIPTION	PURITY*
Zinc	Zn	1-3 mm / 3-6 mm 5 mm \varnothing x 1 mm	99.999 to 99.9999
Zinc Antimonide (98/2 mol%)	Zn-Sb	3-6 mm	99.5 / 99.999
Zinc Arsenide	$ZnAs_2$ / Zn_3As_2	3-6 mm	99.99 to 99.9999
Zinc Oxide	ZnO	1-4 mm / 3-12 mm 12 mm \varnothing x 5 mm	99.9 to 99.995
Zinc Oxide Aluminum Oxide, (AZO) (98/2 mol%)	$ZnO-Al_2O_3$	1-4 mm / 3-6 mm	99.995
Zinc Palladium	ZnPd	3-6 mm	99.99
Zinc Phosphoride	Zn_3P_2	1-3 mm / 3-6 mm	99.9 to 99.999
Zinc Selenide	ZnSe	1-3mm / 3-6 mm / 3-12 mm	99.99 to 99.9999

*Purity based on metallic impurities - vacuum deposition grade.



CHEMICAL	FORMULA	DESCRIPTION	PURITY*
Zinc Sulfide	ZnS	1-3mm / 3-6 mm / 3-12 mm	99.99 to 99.9999
Zinc Sulfide Silicon Dioxide (60/40 mol%)	ZnS-SiO ₂	3-6 mm	99.99
Zinc Manganese Telluride	ZnMnTe	3-6 mm	99.999
Zinc Telluride	ZnTe	3-12 mm	99.99 to 99.999

Zr 40 ZIRCONIUM Base

CHEMICAL	FORMULA	DESCRIPTION	PURITY*
Zirconium	Zr	3 mm Ø x 3 mm / 6 mm Ø x 6 mm 1-3 mm / 1-4 mm / 3-6 mm	99.5 to 99.995
Zirconium Aluminide	ZrAl ₃	3-6 mm	99.5
Zirconium Fluoride	ZrF ₄	1-4 mm	99.95
Zirconium Fluoride	ZrF ₄	3-6 mm	99.9
Zirconium Oxide Hafnium Oxide Tantalum Oxide	ZrO ₂ -HfO ₂ -Ta ₂ O ₅	1-4 mm	99.99
Zirconium Oxide (White)	ZrO ₂	3-12 mm 18 mm Ø x 12 mm	99.7 to 99.99
Zirconium Oxide (White)	ZrO ₂	22 mm Ø x 7 mm / 12 mm Ø x 7 mm / 13.2 mm Ø x 9.2 mm	99.9
Zirconium Oxide	ZrO ₂	22 mm Ø x 5 mm / 10 mm Ø x 10 mm	99.95
Zirconium Oxide	ZrO ₂	1-4 mm / 10 mm Ø x 6 mm	99.95 to 99.99
Zirconium Oxide Magnesium Oxide	ZrO ₂ -MgO	3-12 mm	99.7
Zirconium Oxide Tantalum Oxide (70/30 wt%)	ZrO ₂ -Ta ₂ O ₅	1-4 mm	99.99
Zirconium Oxide Titanium Oxide	ZrO ₂ -TiO ₂	1-4 mm / 10 mm Ø x 10 mm	99.9
Zirconium Oxide Yttrium Oxide, YSZ (92/8 mol%), (97/3 mol%)	ZrO ₂ -Y ₂ O ₃	1-4 mm	99.95

*Purity based on metallic impurities - vacuum deposition grade.



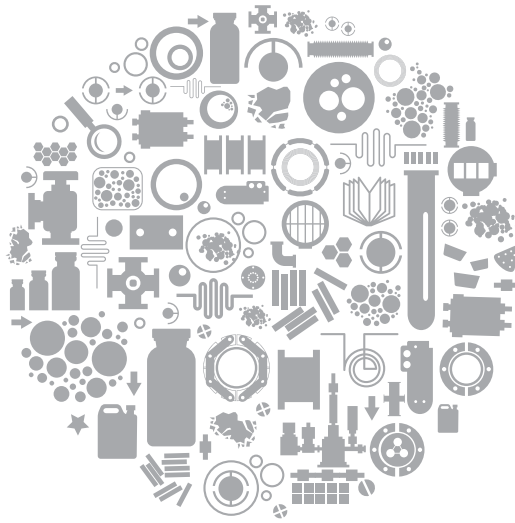

neyco

30 avenue de la Paix
92170 Vanves - France
Tel: +33(0)1 41 90 50 50
Fax: +33(0)1 41 90 50 51

www.neyco.fr



Materials C 2018-1

neyco

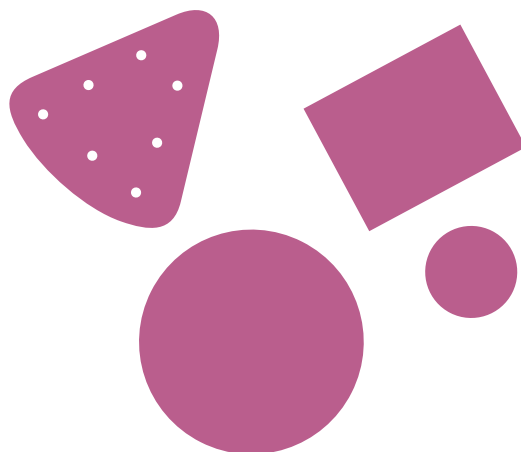

D

MATERIALS SPUTTERING TARGETS

- Manufacturing Processes..... D 03
- Sputtering Targets D 04
- Sputter Yield Guide D 17
- Backing Plates..... D 20
- Mounting of Sputtering Targets..... D 21

Most sputtering targets can be fabricated into a wide range of shapes and sizes. There are some technical limitations to the maximum size for a given single piece construction.

In such cases, a multi-segmented target can be produced with the individual segments joined together by butt or beveled joints.

OUR SPUTTERING TARGETS AT A GLANCE

- Pure metal and alloy targets (99% to 99.9999%), industrial application targets: Al, Ni/Cr, Mo, Ta, Ti, Ti/Al, W...
- Precious metal targets: Ag, Au, Ir, Pd, Pt, Rh... and alloys on request
- Hot pressed oxides and intermetallic targets without binder: Al_2O_3 , AZO, ITO, PZT, SiO_2 , ZnO...
- Circular, rectangular, Delta, ring, tube and any other shape on request
- All targets are delivered with a certificate of analysis

Neyco offers you specific composition according to your needs on request. Don't hesitate to ask us !



Manufacturing Processes

Neyco manufactures sputtering targets from a wide variety of compositions in various purity levels, allowing customers to match targets to their specific requirements and needs. We employ a number of different target manufacturing techniques to yield optimum grain size, density, hardness and composition. The specific manufacturing process depends on the properties of the target material and the end use of the target.

Manufacturing techniques used include:

- Casting
- Ceramic Sintering
- Cold and Hot Isostatic Pressing
- Extrusion
- Hot and Cold Rolling
- Inert Gas Hot-Pressing
- Plasma Spray
- Precision Machining
- Vacuum Hot-Pressing
- Vacuum Melting

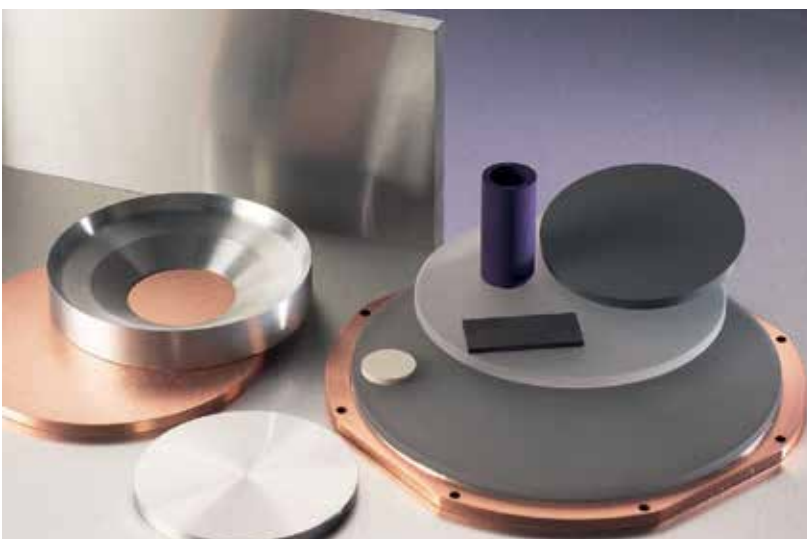

Sputtering Targets

Al 13 ALUMINUM Base

CHEMICAL*	FORMULA	PURITY**
Aluminum	Al	99.99/99.999
Aluminum Antimonide	AlSb	99.99
Aluminum Chromium (95/5)	Al-Cr	99.95
Aluminum Copper (99.5/0.5)	Al-Cu	99.995
Aluminum Copper (90/10), (92/8), (95/5), (98/2), (99/1)	Al-Cu	99.99 to 99.999
Aluminum Copper Silicon (98/1/1)	Al-Cu-Si	99.999
Aluminum Magnesium	AlMg	99.995
Aluminum Magnesium Silicon	AlMgSi	99.99
Aluminum Neodymium	AlNd	99.95
Aluminum Nickel Boron (95.5/4/0.5 at%)	Al-Ni-B	99.99
Aluminum Nickelide	Al ₃ Ni	99.9
Aluminum Nitride	AlN	99 to 99.9
Aluminum Nitride Titanium Nitride	AlN-TiN	99.5
Aluminum Oxide	Al ₂ O ₃	99.99 to 99.999
Aluminum Oxide Tungsten Oxide (95/5 at%)	Al ₂ O ₃ -WO ₃	99.99
Aluminum Oxide Yttrium Oxide (95/5 at%)	Al ₂ O ₃ -Y ₂ O ₃	99.99
Aluminum Silicon Copper	AlSiCu	99.95
Aluminum Silicon (98/2), (99/1)	Al-Si	99.99/99.999
Aluminum Silicon	AlSi	99.999

Sb 51 ANTIMONY Base

CHEMICAL*	FORMULA	PURITY**
Antimony	Sb	99.5/99.999
Antimony Sulfide	Sb ₂ S ₃	99.99
Antimony Telluride	Sb ₂ Te ₃	99.999

Ba 56 BARIUM Base

CHEMICAL*	FORMULA	PURITY**
Barium	Ba	99.9
Barium Ferrite	BaFe ₁₂ O ₁₉	99.9
Barium Fluoride	BaF ₂	99.9/99.995
Barium Lead Oxide	BaPbO ₃	99.5
Barium Manganese Oxide	BaMnO ₃	99.9
Barium Oxide	BaO	99.95
Barium Strontium Titanate, BST	BaSrTiO ₃	99.95
Barium Titanate	BaTiO ₃	99.9/99.95
Barium Zirconate	BaZrO ₃	99.99
Barium Zirconium Titanate	BaZrTiO ₃	99.9

*All alloys are in wt% when not indicated.

**All purities indicated in the tables are based on metallic impurities.

Bi

83

BISMUTH Base

CHEMICAL*	FORMULA	PURITY**
Bismuth	Bi	99.9 to 99.999
Bismuth Aluminum Oxide	BiAlO ₃	99.99
Bismuth Antimonide	BiSb	99.99
Bismuth Antimony Telluride	BiSbTe	99.999
Bismuth Cobalt Oxide	BiCoO ₃	99.95
Bismuth Ferrite	BiFeO ₃	99.99
Bismuth Gallate	BiGa ₂ O ₃	99.99
Bismuth Indium Oxide	BiInO ₃	99.9
Bismuth Iron Titanium Oxide	Bi _{1.02} Fe _{0.98} Ti _{0.02} O ₃	99.9
Bismuth Manganese Oxide	BiMnO ₃	99.95
Bismuth Neodymium Titanium Oxide, BNdT	(Bi _{3.15} Nd _{0.85})Ti ₃ O ₁₂	99.9
Bismuth Oxide	Bi ₂ O ₃	99.9 to 99.99
Bismuth Samarium Ferrite	BiSmFeO ₃	99.9
Bismuth Selenide	Bi ₂ Se ₃	99.999
Bismuth Silicon Oxide	Bi ₂ SiO ₅	99.99
Bismuth Strontium Calcium Copper Oxide, BSCCO (2212)	Bi ₂ Sr ₂ Ca ₁ Cu ₂ O ₈	99.9
Bismuth Strontium Calcium Copper Oxide, BSCCO (2223)	Bi ₂ Sr ₂ Ca ₂ Cu ₃ O ₁₀	99.9
Bismuth Telluride	Bi ₂ Te ₃	99.999
Bismuth Telluride Selenide	BiTe _{1-x} Se _x	99.999
Bismuth Titanate	Bi ₂ Ti ₄ O ₁₁	99.9
Bismuth Vanadate	BiVO ₄	99.99

B

5

BORON Base

CHEMICAL*	FORMULA	PURITY**
Boron	B	99.9 to 99.999
Boron Carbide	B ₄ C	99.5 / 99.9
Boron Nitride	BN	97.5 to 99.9

Cd

48

CADMIUM Base

CHEMICAL*	FORMULA	PURITY**
Cadmium	Cd	99.9 to 99.999
Cadmium Oxide	CdO	99.99
Cadmium Selenide	CdSe	99.99 / 99.995
Cadmium Stannate	Cd ₂ SnO ₄	99.99
Cadmium Sulfide	CdS	99.99 / 99.999
Cadmium Telluride	CdTe	99.999
Cadmium Tin	CdSn	99.99

Ca

20

CALCIUM Base

CHEMICAL*	FORMULA	PURITY**
Calcium Fluoride	CaF ₂	99.99 / 99.995
Calcium Manganate	CaMnO ₃	99.95
Calcium Oxide	CaO	99.99
Calcium Titanate	CaTiO ₃	99.99

Ce

58

CERIUM Base

CHEMICAL*	FORMULA	PURITY**
Cerium	Ce	99.9 / 99.95
Cerium Fluoride	CeF ₃	99.9
Cerium Gadolinium	CeGd	99.95
Cerium Oxide	CeO ₂	99.9

*All alloys are in wt% when not indicated.

**All purities indicated in the tables are based on metallic impurities.

Cs 55 CESIUM Base

CHEMICAL*	FORMULA	PURITY**
Cesium Iodide	CsI	99.99/99.999

Cr 24 CHROMIUM Base

CHEMICAL*	FORMULA	PURITY**
Chromium	Cr	99.8 to 99.99
Chromium Aluminide	CrAl	99.99
Chromium Boride	CrB ₂	99.5
Chromium Carbide	Cr ₃ C ₂	99.5/99.95
Chromium Diboride	CrB ₂	99.5
Chromium Nitride	Cr ₂ N	99.5
Chromium Oxide	Cr ₂ O ₃	99.8 to 99.95
Chromium Silicide	CrSi ₂	99.5/99.9
Chromium Silicide	Cr ₃ Si	99.5
Chromium Titanium (80/20), (95/5)	Cr-Ti	99.9
Chromium Nickel (60/40)	Cr-Ni	99.9
Chromium Nickel Aluminum	CrNiAl	99.9
Chromium Silicon Monoxide (60/40), (70/30)	Cr-SiO	99.5/99.9
Chromium Ruthenium	CrRu	99.95

Co 27 COBALT Base

CHEMICAL*	FORMULA	PURITY**
Cobalt	Co	99.8 to 99.99
Cobalt Boride	Co ₂ B	99.9
Cobalt Chromium Aluminum	CoCrAl	99.95
Cobalt Chromium Iron Aluminum	CoCrFeAl	99.9
Cobalt Chromium Oxide	CoCr ₂ O ₄	99.9
Cobalt Gadolinium	CoGd	99.95
Cobalt Iron	CoFe	99.95
Cobalt Iron (50/50), (60/40), (70/30), (84/16), (90/10)	Co-Fe	99.9/99.95
Cobalt Iron Boron	CoFeB	99.95
Cobalt Oxide	Co ₃ O ₄	99.95
Cobalt Oxide	CoO	99.95
Cobalt Silicide	CoSi ₂	99.5
Cobalt Silicon	CoSi	99.95

*All alloys are in wt% when not indicated.

**All purities indicated in the tables are based on metallic impurities.

Cu 29 COPPER Base

CHEMICAL*	FORMULA	PURITY**
Copper	Cu	99.99/99.995
Copper Aluminum Oxide	CuAl ₂ O ₃	99.9
Copper Aluminum Oxide	CuAlO ₂	99.99
Copper Boron (95/5 at%)	Cu-B	99.9
Copper Gallium	CuGa	99.99/99.995
Copper Germanide	CuGe	99.99
Copper Indium	CuIn	99.99
Copper Indium Gallium	CuInGa	99.99
Copper Indium Gallium Selenide	CuInGaSe ₂	99.99
Copper Iron (99/1)	Cu-Fe	99.95
Copper Magnesium	CuMg	99.99
Copper Nickel	CuNi	99.99
Copper Oxide	CuO	99.7/99.9
Copper Oxide	Cu ₂ O	99.9
Copper Selenide	CuSe	99.99
Copper Selenide	Cu ₂ Se	99.5
Copper Sulfide	Cu ₂ S	99.95
Copper Sulfide	CuS	99.999
Copper Telluride	Cu ₂ Te	99.99
Copper Tin (90/10)	Cu-Sn	99.99
Copper Titanium Oxide	CuTiO ₃	99.99

Dy 66 DYSPROSIUM Base

CHEMICAL*	FORMULA	PURITY**
Dysprosium	Dy	99.95

Er 68 ERBIUM Base

CHEMICAL*	FORMULA	PURITY**
Erbium	Er	99.95
Erbium Fluoride	ErF ₃	99.99
Erbium Oxide	Er ₂ O ₃	99.95/99.99

*All alloys are in wt% when not indicated. .

Eu 63 EUROPIUM Base

CHEMICAL*	FORMULA	PURITY**
Europium	Eu	99.9
Europium Oxide	Eu ₂ O ₃	99.95

Gd 64 GADOLINIUM Base

CHEMICAL*	FORMULA	PURITY**
Gadolinium	Gd	99.9/99.95
Gadolinium Oxide	Gd ₂ O ₃	99.9

Ga 31 GALLIUM Base

CHEMICAL*	FORMULA	PURITY**
Gallium Antimonide	GaSb	99.999
Gallium Arsenide	GaAs	99.999
Gallium Indium Zinc Oxide	Ga ₂ O ₃ -In ₂ O ₃ -ZnO	99.99
Gallium Iron Magnesium Oxide	GaFeMgO ₃	99.9
Gallium Oxide	Ga ₂ O ₃	99.995/ 99.999
Gallium Phosphide	GaP	99.999
Gallium Selenide	Ga ₂ Se ₃	99.99

Ge 32 GERMANIUM Base

CHEMICAL*	FORMULA	PURITY*
Germanium	Ge	99.999
Germanium Antimonide	GeSb	99.999
Germanium Antimony Telluride, GST	Ge ₂ Sb ₃ Te ₅	99.999
Germanium Oxide	GeO ₂	99.99
Germanium Selenide	GeSe	99.999
Germanium Telluride	GeTe	99.999

**All purities indicated in the tables are based on metallic impurities.

Au
79

GOLD Base

CHEMICAL*	FORMULA	PURITY**
Gold	Au	99.95/99.999
Gold Boride	AuB	99.99
Gold Germanium (88/12)	Au-Ge	99.999
Gold Palladium (60/40)	Au-Pd	99.99
Gold Tin (70/30)	Au-Sn	99.99
Gold Zinc (92/8)	Au-Zn	99.99

 See Section E - Precious Metals in this catalogue about Presentation and Precious Metal Recycling.

C
6

GRAPHITE Base

CHEMICAL*	FORMULA	PURITY**
Graphite	C	99.5/99.999
Carbon Nickel (95/5)	C-Ni	99.95

Hf
72

HAFNIUM Base

CHEMICAL*	FORMULA	PURITY**
Hafnium	Hf	99.9 to 99.99
Hafnium Boride	HfB ₂	99.5
Hafnium Carbide	HfC	99.5/99.95
Hafnium Indium Zinc Oxide (0.3/1/1 mol%), (1/1/1 mol%)	HfO ₂ -In ₂ O ₃ -ZnO	99.99
Hafnium Nitride	HfN	99.5
Hafnium Oxide	HfO ₂	99.95
Hafnium Oxide Yttrium Oxide (90/10), (85/15)	HfO ₂ -Y ₂ O ₃	99
Hafnium Oxide Yttrium Oxide (92/8 mol%)	HfO ₂ -Y ₂ O ₃	99.95
Hafnium Silicide	HfSi ₂	99.5/99.8

Ho
67

HOLMIUM Base

CHEMICAL*	FORMULA	PURITY**
Holmium	Ho	99.95
Holmium Manganese Oxide	HoMnO ₃	99.95

In
49

INDIUM Base

CHEMICAL*	FORMULA	PURITY**
Indium	In	99.99/99.999
Indium Antimonide	InSb	99.99/99.999
Indium Arsenide	InAs	99.999
Indium Gallium Zinc Oxide	InGaZnO	99.99
Indium Oxide	In ₂ O ₃	99.99/99.999
Indium Oxide Gallium Oxide, IGO (90/10)	In ₂ O ₃ -Ga ₂ O ₃	99.99
Indium Oxide Zinc Oxide, IZO (90/10)	In ₂ O ₃ -ZnO	99.99
Indium Selenide	In ₂ Se ₃	99.9/99.99
Indium Sulfide	In ₂ S ₃	99.99/99.999
Indium Telluride	InTe	99.999
Indium Tin (90/10)	In-Sn	99.995
Indium Tin Oxide Iron	In ₂ O ₃ -SnO ₂ -Fe	99.99
Indium Tin Oxide, ITO (90/10), (85/15), (80/20)	In ₂ O ₃ -SnO ₂	99.99/99.999
Indium Tin Oxide (91/9 mol%)	In ₂ O ₃ -SnO ₂	99.99/99.999
Indium Tin Zinc Oxide, ITZO (90/3/7)	In ₂ O ₃ -SnO ₂ -ZnO	99.99
Indium Zinc (90/10)	In-Zn	99.99

*All alloys are in wt% when not indicated.

**All purities indicated in the tables are based on metallic impurities.

Ir

77

IRIDIUM Base

CHEMICAL*	FORMULA	PURITY**
Iridium	Ir	99.8/99.95
Iridium Manganese (20/80), (75/25), (80/20)	Ir-Mn	99.95

 See Section E - Precious Metals in this catalogue about Presentation and Precious Metal Recycling.

Fe

26

IRON Base

CHEMICAL*	FORMULA	PURITY**
Iron	Fe	99.6 to 99.99
Iron Boride	FeB	99.5
Iron Carbide	Fe ₃ C	99.9
Iron Copper (98/2 at%)	Fe-Cu	99.995
Iron Copper Niobium Silicon Boron	FeCuNbSiB	99.9
Iron Germanium	FeGe	99.95
Iron Magnesium	FeMg	99.95
Iron Manganese (50/50)	Fe-Mn	99.95
Iron Oxide	Fe ₂ O ₃	99.9
Iron Oxide	Fe ₃ O ₄	99/99.95
Iron Oxide	FeO	99.9
Iron Oxide Cobalt Oxide	Fe ₂ O ₃ -Co ₃ O ₄	99.9
Iron Silicide	FeSi	99.95
Iron Silicide	FeSi ₂	99.9/99.99
Iron Silicon Boron	FeSiB	99.95
Iron Terbium (67/33 at%)	Fe-Tb	99.9
Iron Terbium Cobalt	FeTbCo	99.9

La

57

LANTHANUM Base

CHEMICAL*	FORMULA	PURITY**
Lanthanum	La	99.95
Lanthanum Aluminum Oxide	LaAlO ₃	99.9
Lanthanum Boride	LaB ₆	99.5
Lanthanum Calcium Manganate, LCM	La _{1-x} Ca _x MnO ₃	99.9
Lanthanum Fluoride	LaF ₃	99.9 to 99.998
Lanthanum Nickel Oxide	LaNiO ₃	99.9
Lanthanum Strontium	LaSr	99.95
Lanthanum Strontium Manganate, LSM	La _{1-x} Sr _x MnO ₃	99.9
Lanthanum Strontium Cobaltite	La _{0.9} Sr _{0.1} CoO ₃	99.9
Lanthanum Yttrium	LaY	99.95

Pb

82

LEAD Base

CHEMICAL*	FORMULA	PURITY**
Lead	Pb	99.99
Lead Fluoride	PbF ₂	99.9
Lead Lanthanum ZirconateTitanate, PLZT	PbLa(ZrTi)O ₃	99.9
Lead Oxide	PbO	99.9
Lead Selenide	PbSe	99.999
Lead Telluride	PbTe	99.99
Lead Titanate	PbTiO ₃	99.9
Lead Titanate Lead	PbTiO ₃ -Pb	99.9
Lead Zirconate Titanate, PZT	Pb(ZrTi)O ₃	99.95

*All alloys are in wt% when not indicated.

**All purities indicated in the tables are based on metallic impurities.

Li

3

LITHIUM Base

CHEMICAL*	FORMULA	PURITY**
Lithium Cobalt Oxide	LiCoO ₂	99.9
Lithium Fluoride	LiF	99.9/99.99
Lithium Iron Phosphate	LiFePO ₄	99.9
Lithium Manganate	LiMn ₂ O ₄	99.5
Lithium Niobate	LiNbO ₃	99.9
Lithium Phosphate	Li ₃ PO ₄	99.99

Mg

12

MAGNESIUM Base

CHEMICAL*	FORMULA	PURITY**
Magnesium	Mg	99.9 to 99.999
Magnesium Aluminum Oxide	MgAl ₂ O ₄	99.99
Magnesium Fluoride	MgF ₂	99.5/99.99
Magnesium Germanide	Mg ₂ Ge	99.99
Magnesium Oxide	MgO	99.95
Magnesium Silicide	Mg ₂ Si	99.9
Magnesium Titanate	MgTiO ₃	99.99

Mn

25

MANGANESE Base

CHEMICAL*	FORMULA	PURITY**
Manganese	Mn	99.95/99.99
Manganese Oxide	MnO	99.9/99.95
Manganese Oxide	MnO ₂	99.95
Manganese Titanium (50/50)	Mn-Ti	99.95

Mo

42

MOLYBDENUM Base

CHEMICAL*	FORMULA	PURITY**
Molybdenum	Mo	99.95
Molybdenum Carbide	Mo ₂ C	99.5/99.95
Molybdenum Oxide	MoO ₃	99.95/99.99
Molybdenum Oxide Copper	MoO ₃ -Cu	99.9
Molybdenum Selenide	MoSe ₂	99.99
Molybdenum Silicide	MoSi ₂	99.5 to 99.995
Molybdenum Sulfide	MoS ₂	99/99.9
Molybdenum Telluride	MoTe ₂	99.99

Nd

60

NEODYMIUM Base

CHEMICAL*	FORMULA	PURITY**
Neodymium	Nd	99.95
Neodymium Ferrite	NdFeO ₃	99.99
Neodymium Magnet, NIB	Nd ₂ Fe ₁₄ B	99.95
Neodymium Oxide	Nd ₂ O ₃	99.95

*All alloys are in wt% when not indicated.

**All purities indicated in the tables are based on metallic impurities.

Ni

28

NICKEL Base

CHEMICAL*	FORMULA	PURITY**
Nickel	Ni	99.6 to 99.995
Nickel Aluminum (50/50 at%), (50/50)	Ni-Al	99.95/99.99
Nickel Aluminum Manganese Silicon, Alumel (95/2/2/1)	Ni-Al-Mn-Si	99.95
Nickel Boride	Ni ₂ B	99.5
Nickel Chromium	NiCr	99.95
Nickel Chromium (90/10), (80/20), (40/60)	Ni-Cr	99.9/99.95
Nickel Chromium Iron, Inconel 690	NiCrFe	99.95
Nickel Chromium Silicon (47.5/47.5/5)	Ni-Cr-Si	99.95
Nickel Iron (81/19), (80/20), (80/20 at%)	Ni-Fe	99.95
Nickel Nitride	NiN	99.5
Nickel Oxide	NiO	99 to 99.995
Nickel Platinum (95/5)	Ni-Pt	99.95
Nickel Silicide	NiSi ₂	99.5
Nickel Titanium (50/50)	Ni-Ti	99.95
Nickel Tungsten (50/50 at%), (95/5 at%)	Ni-W	99.9/99.95
Nickel Vanadium (93/7)	Ni-V	99.95

Nb

41

NIOBIUM Base

CHEMICAL*	FORMULA	PURITY**
Niobium	Nb	99.9+ / 99.95
Niobium Aluminide	Nb ₃ Al	99.95
Niobium Carbide	NbC	99.5
Niobium Germanide	Nb ₃ Ge	99.95
Niobium Nitride	NbN	99.5
Niobium Oxide	Nb ₂ O ₅	99.5 to 99.995
Niobium Silicide	NbSi ₂	99.5

Pd

46

PALLADIUM Base

CHEMICAL*	FORMULA	PURITY**
Palladium	Pd	99.95 / 99.99
Palladium Nickel (90/10)	Pd-Ni	99.95

➔ See Section E - Precious Metals in this catalogue about Presentation and Precious Metal Recycling.

Pt

78

PLATINUM Base

CHEMICAL*	FORMULA	PURITY**
Platinum	Pt	99.95 / 99.99
Platinum Palladium (50/50)	Pt-Pd	99.99

➔ See Section E - Precious Metals in this catalogue about Presentation and Precious Metal Recycling.

*All alloys are in wt% when not indicated.

**All purities indicated in the tables are based on metallic impurities.

Pr 59 PRASEODYMIUM Base

CHEMICAL*	FORMULA	PURITY**
Praseodymium	Pr	99.95
Praseodymium Calcium Manganese Oxide, PCMO	Pr _{0.7} Ca _{0.3} MnO ₃	99.9
Praseodymium Oxide	Pr ₆ O ₁₁	99.9

Re 75 RHENIUM Base

CHEMICAL*	FORMULA	PURITY**
Rhenium	Re	99.95/99.99

Rh 45 RHODIUM Base

CHEMICAL*	FORMULA	PURITY**
Rhodium	Rh	99.8/99.95

 See Section E - Precious Metals in this catalogue about Presentation and Precious Metal Recycling.

Ru 44 RUTHENIUM Base

CHEMICAL*	FORMULA	PURITY**
Ruthenium	Ru	99.95

 See Section E - Precious Metals in this catalogue about Presentation and Precious Metal Recycling.

Sm 62 SAMARIUM Base

CHEMICAL*	FORMULA	PURITY**
Samarium	Sm	99.9/99.95
Samarium Aluminide	SmAl ₂	99.99
Samarium Cobalt	SmCo ₅	99.9
Samarium Oxide	Sm ₂ O ₃	99.95/99.99
Samarium Zirconium (50/50), (40/60)	Sm-Zr	99.9

Sc 21 SCANDIUM Base

CHEMICAL*	FORMULA	PURITY**
Scandium	Sc	99.99/99.995
Scandium Oxide	Sc ₂ O ₃	99.995

Se 34 SELENIUM Base

CHEMICAL*	FORMULA	PURITY**
Selenium	Se	99.999
Selenium Germanium (70/30 at%)	Se-Ge	99.999

*All alloys are in wt% when not indicated.

**All purities indicated in the tables are based on metallic impurities.

Si

14

SILICON Base

CHEMICAL*	FORMULA	PURITY**
Silicon	Si	99.999
Silicon Aluminum (92/8), (94/6), (95/5), (96/4), (98/2)	Si-Al	99.99 to 99.999
Silicon Carbide	SiC	99.5
Silicon Chromium	SiCr	99.99
Silicon Dioxide	SiO ₂	99.99 to 99.999
Silicon Germanium	SiGe	99.999
Silicon Germanium	SiGe	99.999
Silicon Monoxide	SiO	99.9 to 99.99
Silicon Nitride	Si ₃ N ₄	99.5/99.9

Ag

47

SILVER Base

CHEMICAL*	FORMULA	PURITY**
Silver	Ag	99.99 / 99.999
Silver Germanium (96/4)	Ag-Ge	99.995
Silver Germanium Tin	AgGeSn	99.995

 See Section E - Precious Metals in this catalogue about Presentation and Precious Metal Recycling.

Na

11

SODIUM Base

CHEMICAL	FORMULA	PURITY*
Sodium Fluoride	NaF	99.9 to 99.99

Sr

38

STRONTIUM Base

CHEMICAL*	FORMULA	PURITY**
Strontium Copper Oxide, SCO	SrCu ₂ O ₂	99.9
Strontium Fluoride	SrF ₂	99.9
Strontium Ruthenate	SrRuO ₃	99.95
Strontium Titanate	SrTiO ₃	99.9
Strontium Titanium Niobium Oxide	SrTiNbO ₃	99.95
Strontium Zirconate	SrZrO ₃	99

Ta

73

TANTALUM Base

CHEMICAL*	FORMULA	PURITY**
Tantalum	Ta	99.95
Tantalum Aluminum	TaAl	99.9
Tantalum Carbide	TaC	99.5
Tantalum Nitride	TaN	99.5
Tantalum Oxide	Ta ₂ O ₅	99.99 to 99.997
Tantalum Selenide	TaSe ₂	99.5 / 99.8
Tantalum Silicide	TaSi ₂	99.5 / 99.99
Tantalum Silicide	Ta ₃ Si ₃	99.5
Tantalum Sulfide	TaS ₂	99.999
Tantalum Telluride	TaTe ₂	99.99

*All alloys are in wt% when not indicated.

**All purities indicated in the tables are based on metallic impurities.

Te

52

TELLURIUM Base

CHEMICAL*	FORMULA	PURITY**
Tellurium	Te	99.5 to 99.999
Tellurium Oxide	TeO ₂	99.99

Tb

65

TERBIUM Base

CHEMICAL*	FORMULA	PURITY**
Terbium	Tb	99.95
Terbium Manganate	TbMnO ₃	99.95

Sn

50

TIN Base

CHEMICAL*	FORMULA	PURITY**
Tin	Sn	99.997/99.999
Tin Antimonide	SnSb	99.99
Tin Copper (63/35 at%)	Sn-Cu	99.99
Tin Monoxide	SnO	99.99
Tin Oxide	SnO ₂	99.9/99.99
Tin Oxide Zinc	SnO ₂ -Zn	99.99
Tin Oxide Antimony Oxide	SnO ₂ -Sb ₂ O ₃	99.99
Tin Selenide	SnSe	99.99
Tin Sulfide	SnS	99.999
Tin Sulfide	SnS ₂	99.999
Tin Zinc	SnZn	99.99

Ti

22

TITANIUM Base

CHEMICAL*	FORMULA	PURITY**
Titanium	Ti	99.8 to 99.995
Titanium Aluminum (30/70), (50/50 at%), (65/35 at%)	Ti-Al	99.9 to 99.99
Titanium Aluminide	Ti ₃ Al	99.9
Titanium Boride	TiB ₂	99.5/99.8
Titanium Carbide	TiC	99.5
Titanium Cobalt (97/3)	Ti-Co	99.95
Titanium Monoxide	TiO	99.9/99.99
Titanium Neodymium (97/3)	Ti-Nd	99.95
Titanium Nickel (50/50)	Ti-Ni	99.95
Titanium Nitride	TiN	99.5/99.9
Titanium Nitride Titanium (90/10)	TiN-Ti	99.5
Titanium Oxide	Ti ₂ O ₃	99.9/99.95
Titanium Oxide	TiO ₂	99.9 to 99.998
Titanium Silicide	TiSi ₂	99.5/99.95
Titanium Silicide	Ti ₅ Si ₃	99.5

*All alloys are in wt% when not indicated.

**All purities indicated in the tables are based on metallic impurities.

W

74

TUNGSTEN Base

CHEMICAL*	FORMULA	PURITY**
Tungsten	W	99.95
Tungsten Boride	W ₂ B	99.5
Tungsten Carbide	WC	99.5
Tungsten Disulfide	WS ₂	99.9
Tungsten Molybdenum (90/10)	W-Mo	99.95
Tungsten Nickel (90/10)	W-Ni	99.95
Tungsten Oxide	WO ₃	99.99
Tungsten Selenide	WSe ₂	99.8
Tungsten Silicide	WSi ₂	99.5/99.95
Tungsten Sulfide	WS ₂	99.8
Tungsten Telluride	WTe ₂	99.9/99.995
Tungsten Titanium (90/10), (80/20)	W-Ti	99.9 to 99.995
Tungsten Rhenium	WRe	99.95

V

23

VANADIUM Base

CHEMICAL*	FORMULA	PURITY**
Vanadium	V	99.7/99.9
Vanadium Boride	VB ₂	99.5
Vanadium Carbide	VC	99.5
Vanadium Nitride	VN	99.5/99.9
Vanadium Oxide	V ₂ O ₅	99.5/99.9
Vanadium Silicide	VSi ₂	99.5

Yb

70

YTTERBIUM Base

CHEMICAL*	FORMULA	PURITY**
Ytterbium	Yb	99.95
Ytterbium Fluoride	YbF ₃	99.995
Ytterbium Oxide	Yb ₂ O ₃	99.99

Y

39

YTTRIUM Base

CHEMICAL*	FORMULA	PURITY**
Yttrium	Y	99.9 to 99.99
Yttrium Barium Cuprate, YBCO	YBa ₂ Cu ₃ O ₇	99.9
Yttrium Fluoride	YF ₃	99.9
Yttrium Iron	Y ₃ Fe ₅	99.9
Yttrium Iron	Y ₂ Fe ₁₇	99.99
Yttrium Iron Garnet, YIG	YFe ₂ O ₄	99.9
Yttrium Manganate	YMnO ₃	99.9
Yttrium Oxide	Y ₂ O ₃	99.95/99.99
Yttrium Silicide	YSi ₂	99.9

*All alloys are in wt% when not indicated.

**All purities indicated in the tables are based on metallic impurities.

Zn

30

ZINC Base

CHEMICAL*	FORMULA	PURITY**
Zinc	Zn	99 to 99.999
Zinc Aluminum (98/2), (99/1)	Zn-Al	99.999
Zinc Antimony	Zn ₄ Sb ₃	99.99
Zinc Copper (65/35 at%)	Zn-Cu	99.99
Zinc Oxide	ZnO	99.99/99.999
Zinc Oxide Aluminum, AZO (97/3), (98/2), (99/1)	ZnO-Al	99.99/99.999
Zinc Oxide Aluminum Oxide, AZO (98/2)	ZnO-Al ₂ O ₃	99.99/99.999
Zinc Oxide Aluminum Oxide, AZO	ZnO-Al ₂ O ₃	99.995
Zinc Oxide Gallium	ZnO-Ga	99.99
Zinc Oxide Gallium Oxide (97/3)	ZnO-Ga ₂ O ₃	99.99
Zinc Oxide Manganese Oxide	ZnO-MnO	99.99
Zinc Oxide Molybdenum Oxide (97/3 at%)	ZnO-MoO ₃	99.99
Zinc Oxide Phosphorus Oxide	ZnO-P ₂ O ₅	99.99
Zinc Oxide Tin	ZnO-Sn	99.99
Zinc Selenide	ZnSe	99.99/99.995
Zinc Sulfide	ZnS	99.99
Zinc Sulfide Silicon Dioxide (80/20)	ZnS-SiO ₂	99.99
Zinc Telluride	ZnTe	99.99
Zinc Tin (50/50)	Zn-Sn	99.99
Zinc Tin Oxide	ZnSnO ₃	99.95/99.99
Zinc Tin Oxide, ZTO	Zn ₂ SnO ₄	99.95

Zr

40

ZIRCONIUM Base

CHEMICAL*	FORMULA	PURITY**
Zirconium	Zr	99.5 to 99.95
Zirconium Boride	ZrB ₂	99.5
Zirconium Carbide	ZrC	99.5
Zirconium Nitride	ZrN	99.5/99.8
Zirconium Oxide	ZrO ₂	99.95 to 99.995
Zirconium Oxide Calcium Oxide (95/5 mol%)	ZrO ₂ -CaO	99
Zirconium Oxide Yttrium Oxide, YSZ (92/8 mol%)/ (95/5 mol%)/ (85-90/10-15 mol%)	ZrO ₂ -Y ₂ O ₃	99.95
Zirconium Oxide Yttrium Oxide, YSZ (84/16)	ZrO ₂ -Y ₂ O ₃	99.99
Zirconium Silicide	ZrSi ₂	99.5
Zirconium Vanadium Titanium	ZrVTi	99.9
Zirconium Yttrium	ZrY	99.95

*All alloys are in wt% when not indicated.

**All purities indicated in the tables are based on metallic impurities

Sputter Yield Guide

The following table of common target materials is useful in making comparisons between deposition processes. The first column lists the different materials.

The second column represents the etch rate data of a standard film deposition.

The sputter rate data in the third column are representative of the film deposition rate at maximum power density (i.e. about 39 W/cm², with direct cooling), a DC source and a 100 mm source-to-substrate distance. Rate will decrease linearly with power levels and depend upon the source-to-substrate distance.

A useful rule of thumb is that the film deposition rate:

1. Decreases by ~10%/cm beyond the 100 mm substrate distance.
2. Increases by ~14%/cm closer than the 100 mm substrate distance.

The fourth column represents the number of target atoms sputtered per argon ion striking the target with a kinetic energy of 500 eV (this energy is typical of an argon plasma) and at 0° incidence angle.

Magnetron design factors such as magnetic field strength – and process parameters such as gas composition and pressure – will affect these data. However, these typical data remain useful for comparison purposes.

TARGET MATERIAL	ETCH RATE (Å/min)	SPUTTER RATE (Å/sec)	YIELD 500 eV	POWER DENSITY (W/cm ²)	
				RECOMMENDED DC	RECOMMENDED RF
Ag	1800	380	2.8	25	10
Al	610	170	1	25	10
AlCu (98/2 wt%)	-	170	-		
Al ₂ O ₃	83	40	0.05	N/A	7.5
AlSi (99/1 wt%)	-	160	-		
As	-	-	4.40		
Au	1080	320	1.70	25	10
Ba	-	-	1.25		
Be	130	100	0.58		
B ₄ C	-	20	-		
BN	-	20	-		
Bi	8800	-	2.67		
C	110	20	0.20		
Ca	-	-	0.89		

TARGET MATERIAL	ETCH RATE (Å/min)	SPUTTER RATE (Å/sec)	YIELD 500 eV	POWER DENSITY (W/cm ²)	
				RECOMMENDED DC	RECOMMENDED RF
Cd	-	-	6.39		
CdS	2200	-	1.2		
Ce	-	-	0.83		
Co	450	190	1.25		
Cr	530	180	1.13	25	10
Cs	-	-	1.82		
Cu	880	320	1.75	25	10
Dy	1100	-	1.49		
Er	1000	-	1.36		
Eu	-	-	1.77		
Fe	350	180	1.16	20	7.5
Ga	-	-	1.57		
GaAs (100)	650	-	0.38		
GaAs (110)	1600	-	0.95		
GaP	1590	-	1.04		
GaSb	1870	-	0.88		
Gd	1100	-	0.92		
Ge	920	160	0.97	20	7.5
Hf	660	110	0.75	20	7.5
Hg	-	-	11.61		
Ho	-	-	1.42		
In	-	800	2.14		
In ₂ O ₃	-	20	-		
InSb	1520	-	0.6		
Ir	590	135	1.06		
ITO	-	20	-	7.5	7.5
K	-	-	1.17		
La	-	-	0.73		
Li	-	-	0.46		
LiNbO ₂	390	-	0.2		
Lu	-	-	0.95		
Mg	225	200	2.03		
MgO	-	20	-		
Mn	870	180	1.82		
Mo	410	120	0.86	20	7.5
Mo ₂ C	280	-	0.2		
MoS ₂	-	40	-		
MoSi ₂	-	110	-		
Na	-	-	1.70		
Nb	470	80	0.63	15	5
Nd	-	-	1.16		
Ni	530	190	1.28	20	7.5
NiFe (80/20 wt%)	500	-	1.2		
Os	500	120	0.84		
P	-	-	2.83		
Pb	2600	-	2.48		
PbTe	3770	-	1.48		

TARGET MATERIAL	ETCH RATE (Å/min)	SPUTTER RATE (Å/sec)	YIELD 500 eV	POWER DENSITY (W/cm ²)	
				RECOMMENDED DC	RECOMMENDED RF
Pd	1100	270	2.09		
Pm	-	-	1.60		
Pr	-	-	1.03		
Pt	620	205	1.27	25	10
Rb	4000	-	1.80		
Re	520	120	0.83		
Rh	720	190	1.30		
Ru	610	180	1.04	25	10
S	-	-	3.71		
Sc	-	-	0.56		
Sb	3238	-	2.83		
Se	-	-	5.16		
Si	370	80	0.54	N/A	7.5
SiC	350	50	0.45		
SiO ₂	330	70	0.23		
Si ₃ N ₄	-	800	-		
Sm	1100	-	2.13		
Sn	1200	800	1.57	25	10
SnO	-	20	-		
Sr	-	-	1.37		
Ta	420	85	0.66		
TaN	-	40	-		
Ta ₂ O ₅	600	40	0.18		
TaC	150	-	0.17		
Tb	-	-	1.00		
Tc	-	-	1.01		
Te	-	-	4.67		
Th	810	85	0.66		
Ti	330	80	0.58	25	10
TiN	-	40	-		
TiO ₂	-	40	-		
Tl	-	-	2.88		
U	730	155	0.94		
V	310	85	0.66		
W	340	80	0.66	20	5
WTi (90/10 wt%)	-	80	-		
WC	-	50	-		
Y	950	85	0.70		
Yb	-	-	2.45		
YBCO	-	10	-		
Zn	-	340	4.61		
ZnO	-	40	-		
ZnS	-	10	-		
Zr	570	-	0.63	20	7.5

This document is being made available to assist users. Every effort has been made to ensure accuracy, completeness and clarity. Unfortunately, in a work of this scope, errors are inevitable. Use this information as a general guide.

Do not hesitate to contact us if you see errors or if you have supplementary information.

Backing Plates

Backing plate is one of the most important components of the PVD sputtering process. Oxygen free, high conductivity (OFHC) Copper is the commonly used material. It exhibits the best electrical and thermal characteristics.

Aluminum, Molybdenum and Stainless Steel can also be used for backing plate fabrication when Copper is not appropriate. For instance, the desired sputtering target material may have a non-compatible coefficient of expansion compared to Copper's which can cause the bonded target assembly to fail irrecoverably. In such case, the use of an alternative backing plate metal is essential.

Our backing plates at a glance:

- **Used material: OFHC, Stainless Steel, Al, Mo...**
- **Manufactured to customer's specifications, or customer's drawing,**
- **Cleaning and packaging according UHV standards.**

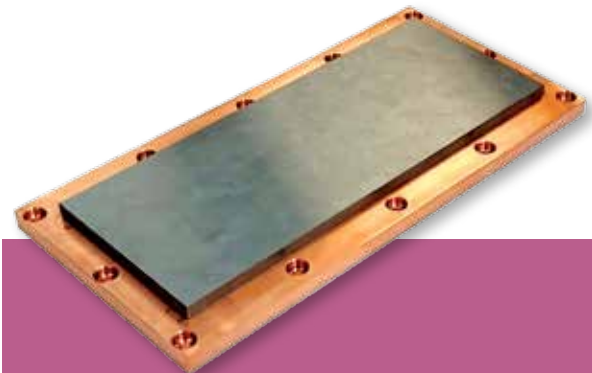

Copper backing plate with target

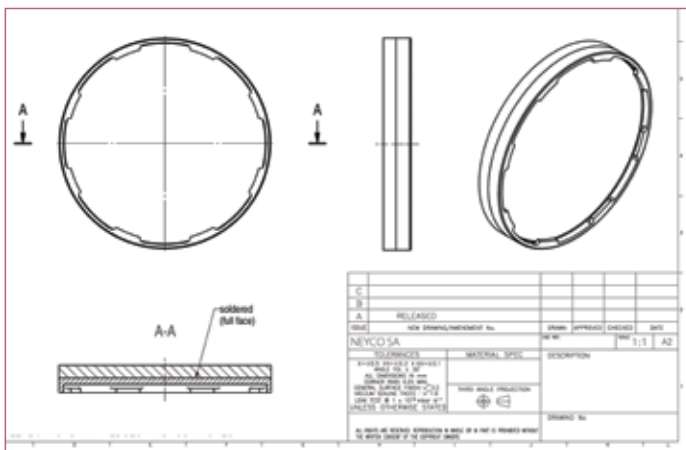

Mounting of Sputtering Targets

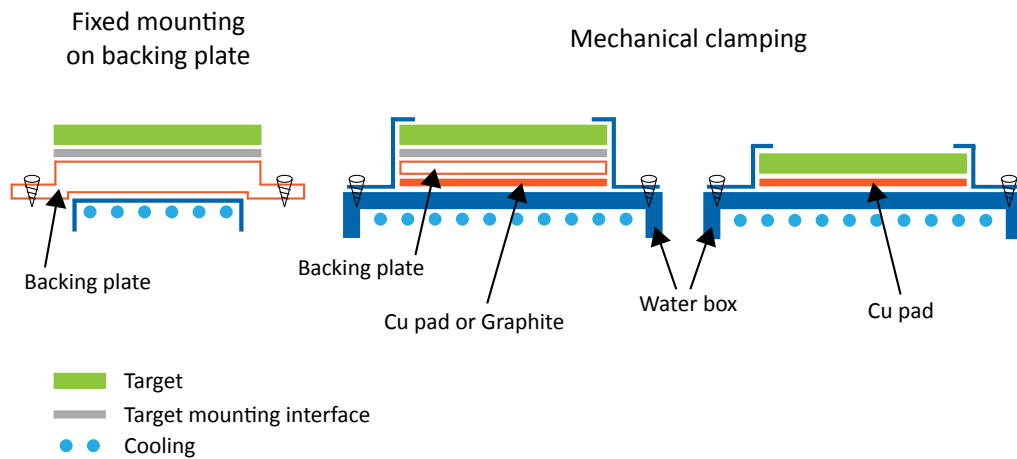

MAIN MOUNTING CHARACTERISTICS

	ADHESIVE MOUNTING					MECHANICAL MOUNTING	
	Ag	In	InSnPb	Elastomeric	Elastomeric + Cu	Graphite Foil	Cu Pad
DC	••	•	•••	-	•••	••	•••
RF	•••	•••	••	•	•••	••	•••
High power DC >5 W/cm ²	•	•	•••	-	•	••	•••
High power RF >3 W/cm ²	••	••	••	•	••	••	•••
Easy mounting	•	•	-	•••	••	•••	•••
Temperature compatibility	•	•	••	••	•••	•••	•••
Mechanical adjustment	••	••	-	-	-	-	•••
Low cost	••	-	-	•••	•••	•••	•••

- not applicable • possible •• good ••• excellent

TARGET MOUNTING IN NEYCO'S LABORATORY

Neyco offers a complete target bonding service on new or existing backing plates:

- Debonding or debrazing of your target
- Backing plate cleaning
- Target bonding: Cu/elastomeric bonding (200°C) or silver based mounting (150°C)
- Cleaning and packaging of the assembly with UHV quality



	ADVANTAGES	DISADVANTAGES
Cu based bonding	<ul style="list-style-type: none"> • Low price • Very good thermal and electrical conductivities • Excellent adhesion between many metals • Suitable for low melting point target materials • Suitable especially for fragile targets 	<ul style="list-style-type: none"> • No mechanical adaptation
Ag based bonding	<ul style="list-style-type: none"> • All types of targets, including very fragile • Good thermal and electrical conductivities • Mechanical adjustment up to 0.4 mm 	<ul style="list-style-type: none"> • The cost of Ag metal • Degrades over 150°C

COPPER PADS FOR SPUTTERING

NEYCO has developed sputtering pads, as a replacement of Indium, Graphite foils or other bondings, for clamped targets.

ADVANTAGES	DISADVANTAGES
<ul style="list-style-type: none"> • Excellent thermal and electrical conductivities • High DC and RF power • Low cost • Mechanical adjustment up to 0.5 mm 	<ul style="list-style-type: none"> • Only for clamped targets

CHARACTERISTICS

- 100% metallic
- Initial thickness 2 mm
- Purity 99.95+%
- Vacuum packed for a direct mounting in secondary vacuum
- 200 mm wide x length on request (up to 1000 mm)
- HV compatible

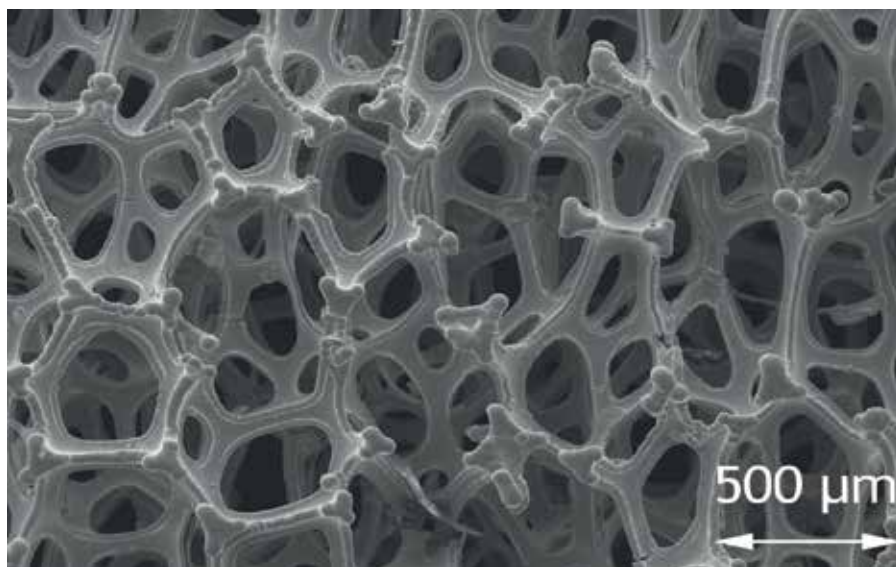

Copper foam pad

GRAPHITE PADS FOR SPUTTERING

NEYCO offers you Graphite pads for sputtering.

The size from ~500 mm wide x length on request. Thickness of 0.2 mm.

ADVANTAGES	DISADVANTAGES
<ul style="list-style-type: none"> • Good thermal and electrical conductivities • Enabling high DC and RF power • Temperature > 250°C • Low cost 	<ul style="list-style-type: none"> • Only for clamped targets • No mechanical adjustment

SILVER-FILLED EPOXY BONDING CEMENT

Silver-filled epoxy cement is a silver-colored thick paste containing the optimum ratio of silver powder to epoxy resin for maximum thermal and electrical conductivity and mechanical strength. The catalyst is a clear to yellow liquid. Both the epoxy cement and the catalyst should be stored in a refrigerator. This will give a shelf life of 6 months.

TYPICAL PROPERTIES OF EPOXY

Volume resistivity	Less than 0.001 Ω.cm
Pot life (after catalyst addition)	30 min at 25°C
Use temperature	-50°C to 115°C
Packaging	114 g



neyco

30 avenue de la Paix
92170 Vanves - France
Tel: +33(0)1 41 90 50 50
Fax: +33(0)1 41 90 50 51

www.neyco.fr



Materials D 2018-1

neyco



MATERIALS PRECIOUS METALS

-
- Precious Metals Presentation..... E 02
 - Vacuum Deposition Materials..... E 04
 - Sputtering Targets E 06
 - Precious Metals Recycling E 08

Precious Metals Presentation

Precious metal thin films play a role in a variety of industrial fields. We provide high-purity sputtering targets and vapour deposition materials in different shapes and sizes to suit every application.

We can supply the following precious metals:

Au 79 GOLD

As the most malleable metal, gold can be processed into fine wire or thin foil. With an extremely high infrared ray reflectivity of 98.4%, thin films of gold are used in space shuttles to protect the crew from the sun's infrared rays.

Melting point	1064.18°C
Boiling point	2800°C
Density	19.32 g/cm ³
Electrical resistance	2.2.10 ⁻⁶ Ω.cm
Thermal conductivity	319 W.m ⁻¹ .K ⁻¹
Vickers hardness in annealed state	22
Thermal expansion coefficient	14.2.10 ⁻⁶ /°C (20-100°C)
Tensile strength	108 MPa
Elongation	42%



Gold pellets

Ir 77 IRIDIUM

The increased hardness and anti-corrosion properties when alloyed with platinum and palladium have been applied to fountain pen nibs and balls for ball pens.

Melting point	2446°C
Boiling point	4527°C
Density	22.56 g/cm ³ (20°C)
Thermal conductivity	147 W.m ⁻¹ .K ⁻¹
Vickers hardness in annealed state	220
Thermal expansion coefficient	6.4.10 ⁻⁶ /°C (20-100°C)
Tensile strength	1088 MPa

Pd
46

PALLADIUM

Palladium can absorb 350-850 times its own volume of hydrogen (at room temperature). With good permeation properties, palladium exhibits unique capabilities in high-purity hydrogen manufacturing equipment.

Melting point	1555°C
Boiling point	3167°C
Density	12.16 g/cm ³ (20°C)
Thermal conductivity	72 W.m ⁻¹ .K ⁻¹
Vickers hardness in annealed state	41
Thermal expansion coefficient	11.8.10 ⁻⁶ /°C (20-100°C)
Tensile strength	170 MPa
Elongation	40%

Pt
78

PLATINUM

Platinum performs a variety of roles from vehicle exhaust gas purification catalyst to the basis of cancer-fighting agents. It is one of the precious metals with tremendous undiscovered powers.

Melting point	1768°C
Boiling point	3827°C
Density	21.37 g/cm ³
Thermal conductivity	72 W.m ⁻¹ .K ⁻¹
Vickers hardness in annealed state	41
Thermal expansion coefficient	8.8.10 ⁻⁶ /°C (20-100°C)
Tensile strength	123 MPa
Elongation	40%

Rh
45

RHODIUM

Chemically stable, rhodium will dissolve gradually in aqua regia when in a powder form, but will not dissolve in acid or aqua regia when in a solid form. Rhodium plating plays a large role in searchlight reflectors and elsewhere performs a decorative function.

Melting point	1963°C
Boiling point	3727°C
Density	12.44 g/cm ³ (20°C)
Thermal conductivity	150 W.m ⁻¹ .K ⁻¹
Vickers hardness in annealed state	101
Thermal expansion coefficient	8.2.10 ⁻⁶ /°C (20-100°C)
Tensile strength	695 MPa
Elongation	5%

Ru
44

RUTHENIUM

Hydrogen is formed through the breakdown of water by the sun's rays in a non-polluting hydrogen energy system that stores hydrogen as fuel. Hopes are rising that ruthenium will act as the essential catalyst to realize this future energy source.

Melting point	2250°C
Boiling point	3900°C
Density	12.06 g/cm ³ (20°C)
Thermal conductivity	105 W.m ⁻¹ .K ⁻¹
Thermal expansion coefficient	9.1.10 ⁻⁶ /°C (20-100°C)

Ag
47

SILVER

Silver is used in large quantities in the form of silver nitrate as a photographic sensitive material. This metal also has the most superior reflectivity of visible light rays of any metal. For this reason, silver is used in mirrors requiring high light reflection.

Melting point	961.78°C
Boiling point	2210°C
Density	10.50 g/cm ³
Electrical resistance	1.62.10 ⁻⁶ Ω.cm
Thermal conductivity	428 W.m ⁻¹ .K ⁻¹
Vickers hardness in annealed state	24
Thermal expansion coefficient	18.9.10 ⁻⁶ /°C (20-100°C)
Tensile strength	147 MPa
Elongation	51%

Vacuum Deposition Materials

We supply materials for the physical vapor deposition as pure elements or alloys upon customer request.

FEATURES

- Sputtering target materials without pinholes, oxides or gases.
- High-purity precious metal vapor deposition materials can be processed into granules, blocks, rods, wires and other forms.

TYPES

	STANDARD ITEMS	HIGH PURITY ITEMS	TYPICAL ALLOYS
Gold series	4N	5N+	AuAg, AuCo, AuGe, AuNi, AuPd, AuSb, AuSi, AuSn, AuZn...
Platinum series	3N5	5N+	PtRh, PtPd, PtCo, PtNi, PtCu...
Iridium series	3N	4N+	IrMn
Rhodium series	3N	4N+	-
Palladium series	3N5	4N+	AuPd, PdNi, PtPd
Ruthenium series	3N	4N+	-
Silver series	4N	5N+	AgAu, AgCu, AgGe, AgGeSn, AgNi, AgSi...



Silver pellets



Platinum pellets

E

APPLICATIONS

Thin film for die-bonding, LED (electrodes), quartz crystals (patterning electrodes), CD-R, DVD, gate electrodes for electronic devices, electrodes for electronic devices and oxide dielectric elements, etc.

DELIVERY FORMS

- Pellets (diameter 3 mm x 6 mm long kept in inventory for Au, Pd and Pt)
- Tube
- Rod
- Target
- Wire [evaporation wires and bonding wires (from 18 μ diameter)]
- Foil
- Ribbon
- Cone
- Others on request

Please ask for your dimensions.

All sputtering targets and evaporation materials dedicated to vacuum thin films are delivered along with a specific certificate of analysis.

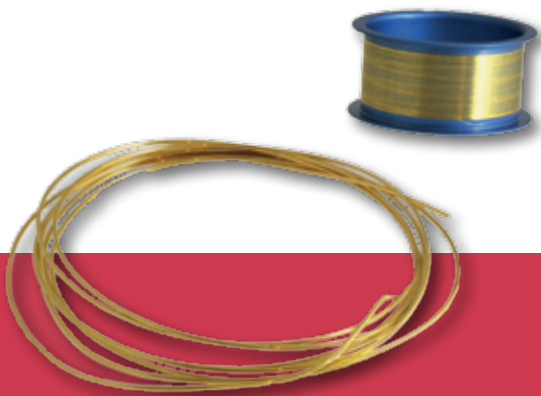

Gold wire and bonding wire

 See Section K- Wire & Foils - Bonding Wires in this catalogue for Gold bonding wires.

Sputtering Targets

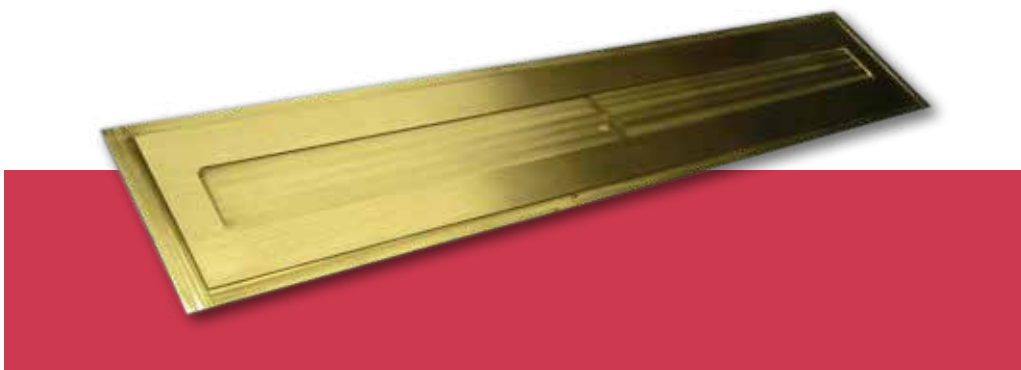

We provide high-purity sputtering targets in different sizes to suit every application:

- flat targets, all diameters and dimensions:



- enhanced targets according your magnetron:



Au
79

GOLD Base

CHEMICAL	FORMULA	PURITY*
Gold	Au	99.99/99.999
Gold Germanium (88/12 wt%)	Au-Ge	99.999
Gold Palladium (60/40 wt%)	Au-Pd	99.99
Gold Tin (70/30 wt%)	Au-Sn	99.99
Gold Zinc (92/8 wt%)	Au-Zn	99.99

Ir
77

IRIDIUM Base

CHEMICAL	FORMULA	PURITY*
Iridium	Ir	99.8/99.95
Iridium Manganese (20/80 wt%), (75/25 wt%), (80/20 wt%)	Ir-Mn	99.95

Pd
46

PALLADIUM Base

CHEMICAL	FORMULA	PURITY*
Palladium	Pd	99.95/99.99
Palladium Nickel (90/10 wt%)	Pd-Ni	99.95

Pt
78

PLATINUM Base

CHEMICAL	FORMULA	PURITY*
Platinum	Pt	99.95/99.99
Platinum Palladium (50/50 wt%)	Pt-Pd	99.99

Rh
45

RHODIUM Base

CHEMICAL	FORMULA	PURITY*
Rhodium	Rh	99.8/99.95

Ru
44

RUTHENIUM Base

CHEMICAL	FORMULA	PURITY*
Ruthenium	Ru	99.95

Ag
47

SILVER Base

CHEMICAL	FORMULA	PURITY*
Silver	Ag	99.99/99.999
Silver Germanium (96/4 wt%)	Ag-Ge	99.995
Silver Germanium Tin	AgGeSn	99.995

Other alloys and purities are available on request.

 See Section D - Sputtering Targets in this catalogue for additional services such as Backing Plates and Bonding of Sputtering Targets.

*Purity based on metallic impurities.

Precious Metals Recycling

Precious metals are found in many shapes and forms in products that surround us. We cover all aspects, from the recovery and refining of scraps to re-manufacturing into products.

We accept for recycling all scraps containing:

- Gold, Au
- Platinum, Pt
- Palladium, Pd
- Silver, Ag
- Iridium, Ir
- Ruthenium, Ru
- Rhodium, Rh

FEATURES

- Physical return and delivery as precious metal products.
- Proper equipments for any form of scraps.
- Management of scraps as a valuable based on international environmental standard.
- Crushing scraps accepted.
- Recycling and precision cleaning of vapor deposition multiple layers is also available.

We will quickly determine the value of the pure metals and transfer it to you on your weight account.



Gold scraps



Platinum used target



neyco

30 avenue de la Paix
92170 Vanves - France
Tel: +33(0)1 41 90 50 50
Fax: +33(0)1 41 90 50 51

www.neyco.fr



Materials E 2018-1

neyco



MATERIALS

REFRACTORY

MATERIALS

- Refractory Metals..... F 02
- Refractory Ceramics..... F 05
- Graphite & PG Parts F 08
- Heating Elements..... F 09

Refractory Metals

Refractory metals qualities (Molybdenum, Niobium, Tantalum, Tungsten, Tungsten alloys) at a glance:

- Very high melting point
- Very low vapor pressure
- Low thermal expansion
- Extremely good corrosion resistance
(against molten metals and glass)

CHEMICAL & PHYSICAL PROPERTIES

Mo 42 MOLYBDENUM

Melting point	2610°C
Boiling point	4825°C
Density	10.28 g.cm ⁻³ (20°C)
Thermal conductivity	138 W.m ⁻¹ .K ⁻¹
Molar heat capacity	24.06 J.mol ⁻¹ .K ⁻¹
1 st ionization energy	684.3 kJ.mol ⁻¹
Electrical resistivity	53.4 nΩ.m (at 20°C)
Thermal expansion	4.8 μm.m ⁻¹ .K ⁻¹ (at 25°C)
Vickers hardness	1530 MPa
Mohs hardness	5.5
Young's modulus	329 GPa
Tensile strength	560-1150 MPa
Elongation	< 20%

Nb 41 NIOBIUM

Melting point	2468°C
Boiling point	4927°C
Density	8.57 g.cm ⁻³ (20°C)
Thermal conductivity	53.7 W.m ⁻¹ .K ⁻¹
Molar heat capacity	24.60 J.mol ⁻¹ .K ⁻¹
1 st ionization energy	652.1 kJ.mol ⁻¹
Electrical resistivity	152 nΩ.m (at 0°C)
Thermal expansion	7.3 μm.m ⁻¹ .K ⁻¹ (at 25°C)
Vickers hardness	1320 MPa
Mohs hardness	6
Young's modulus	105 GPa
Tensile strength	125-195 MPa
Elongation	50%

Ta
73

TANTALUM

Melting point	2996°C
Boiling point	5458°C
Density	16.6 g.cm ⁻³ (20°C)
Thermal conductivity	57.5 W.m ⁻¹ .K ⁻¹
Molar heat capacity	25.36 J.mol ⁻¹ .K ⁻¹
1 st ionization energy	761 kJ.mol ⁻¹
Electrical resistivity	131 nΩ.m (at 20°C)
Thermal expansion	6.3 μm.m ⁻¹ .K ⁻¹ (at 25°C)
Vickers hardness	873 MPa
Mohs hardness	6.5
Young's modulus	186 GPa
Tensile strength	285 MPa
Elongation	> 30%

W
74

TUNGSTEN

Melting point	3410°C
Boiling point	5555°C
Density	19.35 g.cm ⁻³ (20°C)
Thermal conductivity	173 W.m ⁻¹ .K ⁻¹
Molar heat capacity	24.27 J.mol ⁻¹ .K ⁻¹
1 st ionization energy	777 kJ.mol ⁻¹
Electrical resistivity	52.8 nΩ.m (at 20°C)
Thermal expansion	4.5 μm.m ⁻¹ .K ⁻¹ (at 25°C)
Vickers hardness	3430 MPa
Mohs hardness	7.5
Young's modulus	411 GPa
Tensile strength	1510 MPa
Elongation	< 2%

F

MATERIALS

Neyco provides Molybdenum, Niobium, Tantalum, Tungsten and main alloys:

- WC, WZr, WCe, WFe, WRe, WCu, WAg, WNiFe,
- Ta₂O₅, TaCu, TaW, TaNb,
- MoW, MoRe, MoTa, MoNb, TZM, MHC.

TYPE OF PRODUCTS

Powder, wire, tube, target, rod, foil, plate, sheet, crucible, liner and machined parts on request.

MANUFACTURING ON REQUEST

Neyco manufactures according to your drawings or specifications all parts you need in refractory metals:

- Standard or special Mo molyblocks
- Sample holders
- Multi-wafer platens washers
- Various Mo, Ni or Ta machined parts
- Mo, Ta, W crucible liners
- Mo and Ta screws and nuts

➔ See Section H in this catalogue about **crucible liners**.

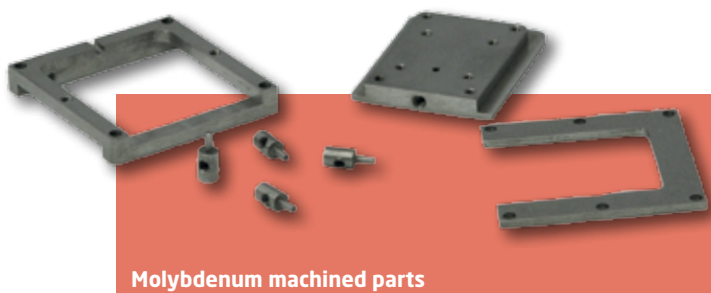

Molybdenum machined parts

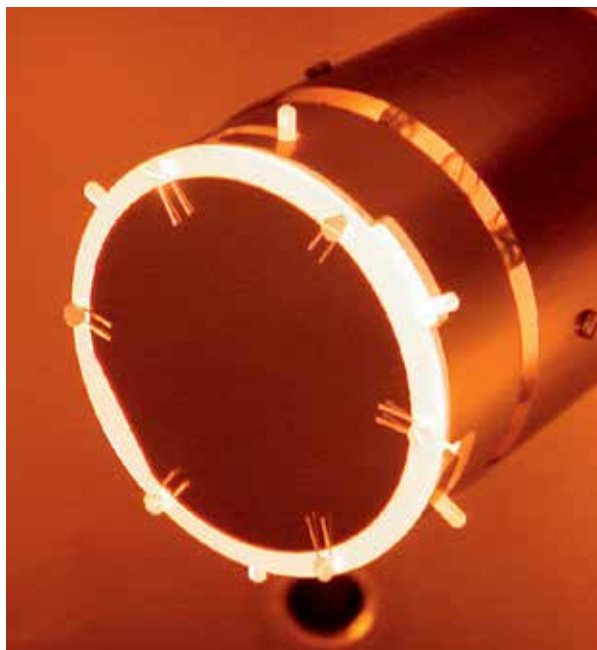

Heated molyblock with Silicon wafer

SCREWS

Molybdenum and Tantalum screws are produced for high temperature and vacuum environments.

We provide in the same materials threaded rods, nuts and washers.



SIZE	LENGTH	TYPE	
M2 to M20	On request	Slotted heads	
		Hexagon heads	
		Hexagon socket heads (Allen)	
		Set screws	
		Nuts	
		Washers	

Refractory Ceramics

By definition, ceramics are non-metallic materials, inorganic, obtained by the action of high temperatures.

During firing a ceramic raw material undergoes an irreversible transformation and acquires new properties. These properties are well known : durability, wear and heat resistance.

Neyco provides a wide range of technical ceramics that will fit to all your specifications. We are able to produce a lot of ceramics parts on drawings or as per our standards dimensions (E-beam liners). Depending on your specifications, your usage constraints, work environment and the desired characteristics, we provide you with the most appropriate material for your application.

MAIN PROPERTIES

- High hardness
- High temperature resistance
- Abrasion resistance
- Precision machining
- Suitable for polishing
- Low porosity
- Chemically inert
- High corrosion resistance



Alumina parts

TYPES OF PRODUCTS

- Rectangular plates
- Discs
- Tubes & rods
- Crucible liners
- Boats
- Screws, nuts & bolts
- Substrates
- All parts according specific drawings

 See Section H in this catalogue about *crucible and liners*

OXIDES

STANDARD SPECIFICATIONS

	ALUMINA	ZIRCONIA OXIDE		QUARTZ
	Al ₂ O ₃ (99.7%)	ZrO ₂ /MgO	ZrO ₂ /Y ₂ O ₃	SiO ₂
Colour	White	Yellow	White	Clear
MECHANICAL PROPERTIES				
Hardness (Mohs)	9	6.5	6.5	7
Young Modulus (GPa)	300 - 400	200	220	70
Max use temperature (°C) in air	1750	1200	1000	1200
Melting Point (°C)	2050	1200	1000	-
Density (g/cm ³)	3.9	5.5 - 5.9	6 - 6.7	2.21
Flexural strength, 3 points (MPa) at 20°C	250	360	540	80
Compressive strength (MPa) at 20°C	1800	3500	6000	650 - 1100
ELECTRICAL PROPERTIES				
Electrical resistivity (Ω.cm) at 20°C	10 ¹²	> 10 ¹⁰	> 10 ⁹	10 ¹⁸
Dielectric strength (kV/mm)	10 - 20	2 - 10	9	25 - 40
THERMAL PROPERTIES				
Thermal conductivity (W/m ⁻¹ .K ⁻¹) at 20°C	29	1.9	3	1.4
Linear expansion (x10 ⁻⁶ /K) 20°C to 1000°C	8.6	9	11	0.58

CARBIDES & NITRIDES

STANDARD SPECIFICATIONS

	CARBIDES		NITRIDES		
	Boron carbide	Silicon carbide	Boron nitride	Silicon nitride	Aluminum nitride
	B ₄ C	SiC	BN	Si ₃ N ₄	AlN
Colour	Grey, black	Black	White	Grey, black	Grey, white
MECHANICAL PROPERTIES					
Hardness (Mohs)	9.5	9 - 10	2	9 - 8	5 - 7
Young Modulus (GPa)	450	420	20 - 100	315	318
Max use temperature (°C) in air	600 - 800	1500	1200	1500	1200
Melting Point (°C)	2460	2500	2600	1900	2200
Density (g/cm ³)	2.5	3.1 - 3.2	1.9 - 2.3	2.5 - 3.2	3.3
Flexural strength, 3 points (MPa) at 20°C		610	65 - 94	200	300
Compressive strength (MPa) at 20°C	1400 - 3400	1725 - 2500	143 - 186	1400	2000
ELECTRICAL PROPERTIES					
Electrical resistivity (Ω.cm) at 20°C	10 ³	10 ² - 10 ⁶	10 ¹⁴	10 ¹² - 10 ¹⁵	> 10 ¹⁴
Dielectric strength (kV/mm)	-	17	88	15	16 - 20
THERMAL PROPERTIES					
Thermal conductivity (W/m ⁻¹ .K ⁻¹) at 20°C	30 - 90	63 - 155	30 - 34	18	180
Linear expansion (x10 ⁻⁶ /K) 20°C to 1000°C	5.6	4 - 5	1 - 3	3 - 4	4.5 - 5.5

OTHER CERAMICS

STANDARD SPECIFICATIONS

	MULLITE	SILICON	MACOR®
	Al ₂ O ₃ + SiO ₂	Si	Al ₂ O ₃ + SiC
Colour	White	Black, blue	White
MECHANICAL PROPERTIES			
Hardness (Mohs)	6 - 8	7	250 (Knopp, 100 g)
Young Modulus (GPa)	100	130	66.9
Max use temperature (°C) in air	1600	4800	1000
Melting Point (°C)	-	1414	-
Density (g/cm ³)	2.7	2.33	2.52
Flexural strength, 3 points (MPa) at 20°C	120	210	94
Compressive strength (MPa) at 20°C	550	-	345
ELECTRICAL PROPERTIES			
Electrical resistivity (Ω.cm) at 20°C	10 ¹³	-	10 ¹⁶
Dielectric strength (kV/mm)	10	-	40
THERMAL PROPERTIES			
Thermal conductivity (W/m ³ .K ⁻¹) at 20°C	2 - 3.5	148	1.46
Linear expansion (x10 ⁻⁶ /K) 20°C to 1000°C	5.3 - 5.7	4.68	9.3 - 12.6



BN-TiB₂ boat source



BN-TiB₂ crucible



Ceramics machined parts

Graphite & PG Parts

Graphite is a mineral of extremes. It is extremely soft, cleaves with very light pressure, and has a very low specific gravity. In contrast, it is extremely resistant to heat and nearly inert in contact with almost any other material. These extreme properties give it a wide range of uses in metallurgy and manufacturing.

TYPES OF PRODUCTS

- Wire
- Powders
- Tube & rod
- Foil/Sheet/Plate
- Target
- Crucible
- Heater
- Composite parts
- All parts according specific drawings

STANDARD SPECIFICATIONS

	GRAPHITE
Colour	Black
MECHANICAL PROPERTIES	
Hardness (Mohs)	0.1 - 1.5
Young Modulus (GPa)	4.8
Max use temperature (°C) in air	3650
Melting Point (°C)	-
Density (g/cm ³)	1.6 - 1.75
Flexural strength, 3 points (MPa) at 20°C	50
Compressive strength (MPa) at 20°C	96
ELECTRICAL PROPERTIES	
Electrical resistivity (Ω.cm) at 20°C	7.10 ⁻³
Dielectric strength (kV/mm)	-
THERMAL PROPERTIES	
Thermal conductivity (W/m ¹ .K ⁻¹) at 20°C	24
Linear expansion (x10 ⁻⁶ /K) 20°C to 1000°C	8.4

POSSIBLE COATING:

- Pyrolytic
- SiC
- Si₃N₄



Vitreous Carbon crucible

Heating Elements

TUNGSTEN FILAMENTS

Neyco provides single wire and multi-strand filaments for thermal applications, such as:

- Vacuum metallization
- Vacuum lamps
- Electron emission (E-beam)
- Ion neutralization (ion-beam)
- Black Tungsten used as heating resistance (atmospheric pressure)

EXAMPLES

- Tungsten filaments with 9 strands: 0.76x3x3x1650 mm, purity = 99.95%
- Tungsten filaments with 2 or 3 strands
- Tungsten wires \varnothing 15 to 100 μ m

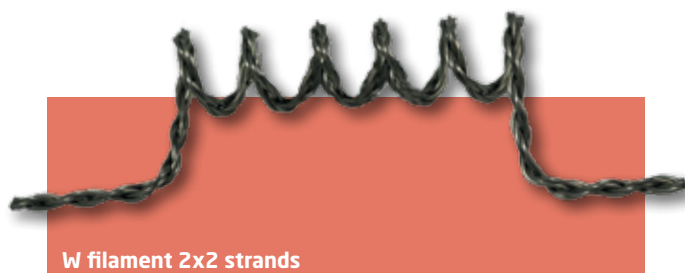

PBN/PG HEATING ELEMENTS

PBN/PG resistance heating elements combine the unique electrical, chemical, and thermal properties of PBN, a dielectric material, and Pyrolytic Graphite (PG), an electrical conductor, to produce a truly advanced heating system.

These non-brittle refractory materials owe their exceptional purity to the high temperature, chemical vapor deposition (CVD) production method. The high thermal conductivity and anisotropy of both materials result in excellent thermal uniformity.

PERFORMANCE ADVANTAGES

PBN/PG “printed circuit” heaters utilize PBN as an insulating substrate and Pyrolytic Graphite as the resistive element. In non-oxidizing environments, this combination of unique materials delivers performance advantages not available in conventional thermal systems.

- Operating temperatures: 1500°C and higher
- Superior performance in ultra-high vacuum
- Chemically inert to most corrosive gases, liquids
- Unaffected by most molten metals
- Long life, dimensionally and electrically stable
- High resistance for low cost power supplies
- Mechanically durable, thermally shock resistant
- Unaffected by vibration
- Tailored thermal gradients for specific requirements
- Ultra-fast response, low thermal mass
- Power densities: 35 W/cm² and higher
- Dielectric, fully dense, ceramic surface
- Often suitable for slightly oxidizing atmospheres

APPLICATIONS

- PVD
- Ion-implant
- MOCVD
- CVD
- PLD
- PE-CVD

DESIGN VERSATILITY

We manufacture heaters as flat plates, with surface electrical connections inside the heated area or located outside the heated area on tabs. Heaters can also be made as 3-D elements on chemical vapor deposited (CVD) PBN crucibles and tubes.

PBN/PG Heaters have been made as small as 5 mm diameter, and as large as 300 mm.

Location of the contact tabs provides design flexibility for enhanced thermal uniformity. Resistance patterns can be circular or diagonal, and can have varying web width to tailor local flux. Multiple, independent zones can be incorporated for flexible thermal management.

PRE-ENGINEERED HEATER SOLUTIONS

Neyco's Pre-engineered Ceramic Heaters are demonstrated solutions with field-tested designs that offer outstanding thermal stability and performance in applications like epi wafer processing and high temperature process development. They offer the electrical, chemical and thermal properties of combining Pyrolytic Boron Nitride (PBN) and Pyrolytic Graphite (PG) in custom engineered solutions without the time and expense involved in refining and testing a new design.

These pre-engineered designs were once custom solutions. They have since been routinely manufactured to solve common challenges in demanding heating applications, allowing us to pass along a discounted price compared to custom-made heaters. We can also customize these ceramic heaters for your unique application or equipment.



Disc Heater



Disc Heater With Tabs

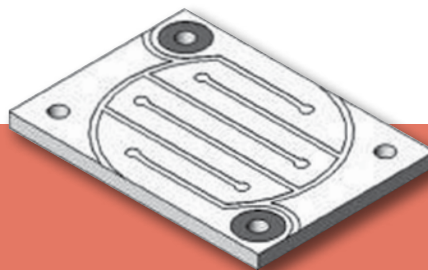

Rectangular Heater

ORDERING INFORMATION

- Disc Heaters:

P/N	HEATED DIAMETER inch (mm)	RESISTANCE AT ROOM T° (Ω)	V	A	W
PCPBNC10	1.00 (25.4)	10-16	40	8	300
PCPBNC15	1.50 (38.1)	10-16	70	10	700
PCPBNC20	2.00 (50.8)	15-25	110	15	1300
PCPBNC25	2.50 (63.5)	22-35	180	15	2000
PCPBNC30	3.00 (76.2)	22-35	208	20	3000

- Disc Heaters With Tabs:

P/N	HEATED DIAMETER inch (mm)	CONTACT SPACING inch (mm)	RESISTANCE AT ROOM T° (Ω)
PCPBNP05	0.50 (12.7)	0.70 (17.8)	5-7
PCPBNP07	0.75 (19.0)	1.35 (34.2)	9-15
PCPBNP10	1.00 (25.4)	1.50 (38.1)	9-15
PCPBNP17	1.75 (44.5)	2.50 (63.5)	17-30
PCPBNP20	2.00 (50.8)	2.50 (63.5)	15-25

- Rectangular Heaters:

P/N	HEATED DIAMETER inch (mm)	CONTACT SPACING inch (mm)	RESISTANCE AT ROOM T° (Ω)
PCPBNR10	0.98 (25.0)	1.11 (28.2)	7-10
PCPBNR20	1.97 (50.0)	1.92 (48.8)	11-15
PCPBNR30	2.95 (75.0)	2.97 (75.4)	16-22



neyco

30 avenue de la Paix
92170 Vanves - France
Tel: +33(0)1 41 90 50 50
Fax: +33(0)1 41 90 50 51

www.neyco.fr



Materials F 2018-1

neyco



MATERIALS

FUEL CELLS

- Electrolyte Powders G 03
- Cathode Powders..... G 06
- Anode Powders G 08
- Inks G 09
- Cells and Substrates G 11
- Seal Materials G 13

Neyco and fuelcellmaterials.com are the premier source for solid oxide fuel cell materials, components, test fixtures and fabrication aides. Our technology, quality and customer support have made us a leader in the fuel cell industry. Backed by our expertise, research and industry knowledge we specialize in providing the highest quality solid oxide fuel cell and fuel processing products to our clients.



Electrolyte Powders

NANOSCALE ELECTROLYTE POWDERS

Nano grade electrolyte powders offer truly nanocrystalline materials with 5 to 10 nanometer particles. Nano grade powders offer tremendous amounts of active surface area per volume of materials, helping extend triple-phase boundaries and lower processing temperatures. We have the processing knowledge to tailor these materials for specific customer materials.

- Using processing techniques that deliver a high purity reproducible electrolyte powder.
- Designed for electrochemical applications.
- Designed as a sintering aid, catalyst support, or a component for mixed conducting anodes and cathodes to enhance catalytic activities.



P/N	PRODUCT NAME	FORMULATION	SURFACE AREA	CRYSTALLITE SIZE	QUANTITIES
111101	GDC-10 Nano Grade	$Gd_{0.10}Ce_{0.90}O_{1.95}$	> 100 m ² /g	5-10 nm*	150 g 500 g 1 kg 5 kg
111102	GDC-20 Nano Grade	$Gd_{0.20}Ce_{0.80}O_{1.95}$	> 100 m ² /g	5-10 nm*	
111202	SDC-20 Nano Grade	$Sm_{0.20}Ce_{0.80}O_{1.95}$	> 100 m ² /g	5-10 nm*	
111301	YSZ8 Nano Grade	$(Y_2O_3)_{0.08}(ZrO_2)_{0.92}$	> 100 m ² /g	5-10 nm*	

*Crystallite size is an approximation based on surface area calculations.

PREMIUM ELECTROLYTE POWDERS

Premium grade electrolyte powders are designed to provide high performance materials with wide processing flexibility. Premium Powders provide lab researchers with the confidence that their research has a foundation in proven, industrially scaled and traceable powders, while providing developers and manufacturers with a scalable high quality powders to aid in commercialization.

- Industry-standard material formulations to provide high end performance and a baseline for materials development and optimization studies.
- Tailored for enhanced sinterability, and lower processing temperatures to provide you the widest possible processing options.
- Batch-to-batch reproducibility and traceability.
- Industry leading characterization and reporting to speed your research and development cycles.



P/N	PRODUCT NAME	FORMULATION	SURFACE AREA	PSD (d50)	QUANTITIES
114101	GDC-10 Premium Grade	$Gd_{0.10}Ce_{0.90}O_{1.95}$	10.0 - 14.0 m ² /g	0.10 - 0.50 μm	500 g 1 kg 5 kg
114201	SDC-20 Premium Grade	$Sm_{0.20}Ce_{0.80}O_{1.95}$	10.0 - 14.0 m ² /g	0.10 - 0.50 μm	

CERAMIC GRADE CERIA POWDERS

We offer Gadolinium and Samarium doped Ceria powders in two grades. The Tape Cast grade is tailored for processes that require high slurry solids loading, such as tape or slip casting. The Mid grade is made to provide excellent sinterability at lower processing temperatures. These powders are also suitable for pellet pressing and other non-aqueous manufacturing processes.

- We have the ability to make material in larger quantities than what we currently offer.
- Custom formulations and/or physical specification changes are available.



P/N	PRODUCT NAME	FORMULATION	SURFACE AREA	PSD (d50)	QUANTITIES
112101	GDC-10 TC Grade	$Gd_{0.10}Ce_{0.90}O_{1.95}$	5 - 8 m ² /g	0.3 - 0.5 μm	150 g 500 g 1 kg 5 kg
112102	GDC-20 TC Grade	$Gd_{0.20}Ce_{0.80}O_{1.95}$	5 - 8 m ² /g	0.3 - 0.5 μm	
112202	SDC-20 TC Grade	$Sm_{0.20}Ce_{0.80}O_{1.95}$	5 - 8 m ² /g	0.3 - 0.5 μm	
113101	GDC-10 M Grade	$Gd_{0.10}Ce_{0.90}O_{1.95}$	30 - 40 m ² /g	0.3 - 0.5 μm	
113102	GDC-20 M Grade	$Gd_{0.20}Ce_{0.80}O_{1.95}$	30 - 40 m ² /g	0.3 - 0.5 μm	
113202	SDC-20 M Grade	$Sm_{0.20}Ce_{0.80}O_{1.95}$	30 - 40 m ² /g	0.3 - 0.5 μm	

MICRON-SUBMICRON ELECTROLYTE POWDERS

We offer a broad selection of micron to submicron electrolyte powders, including Yttrium-stabilized Zirconia (YSZ) and LSGM. YSZ is a purely ionic conductive electrolyte over a wider range of oxygen partial pressures, which finds wide applicability in SOFCs, oxygen generation systems and sensors.

- YSZ TC is our most popular grade for tape casting electrolyte material for SOFCs due to its ideal surface area and particle size distribution.
- Coarser YSZ powders are tailored for the production of high porosity electrodes with stable microstructure.
- LSGM offers high conducting properties at intermediate operating temperatures while providing stability.
- Custom formulations and/or physical specification changes are available.



P/N	PRODUCT NAME	FORMULATION	SURFACE AREA	PSD (d50)	QUANTITIES
312005	YSZ8 TC Grade	$(Y_2O_3)_{0.08}(ZrO_2)_{0.92}$	6 - 9 m ² /g	0.5 - 0.7 μm	150 g 500 g 1 kg
312006	ScCeSZ TC Grade	$(Sc_2O_3)_{0.1}(CeO_2)_{0.01}(ZrO_2)_{0.89}$	10 - 12 m ² /g	0.5 - 0.7 μm	
312007	Sc10SZ TC Grade	$(ZrO_2)_{0.90}(Sc_2O_3)_{0.10}$	8 - 11 m ² /g	0.5 - 0.7 μm	
312008	YSZ8-U35 Standard Grade	$(Y_2O_3)_{0.08}(ZrO_2)_{0.92}$	1 - 3 m ² /g	3.0 - 5.0 μm	
312009	YSZ8-U1 Fine Grade	$(Y_2O_3)_{0.08}(ZrO_2)_{0.92}$	9 - 14 m ² /g	0.3 - 0.5 μm	
312021	YSZ8 Spray Dried	$(Y_2O_3)_{0.08}(ZrO_2)_{0.92}$	13 - 19 m ² /g	-	
312022	YSZ8-U5 Mid Grade	$(Y_2O_3)_{0.08}(ZrO_2)_{0.92}$	3 - 7 m ² /g	0.9 - 1.2 μm	
121501	LSGM TC Grade	$La_{0.80}Sr_{0.20}Ga_{0.80}Mg_{0.20}O_{3-x}$	4 - 8 m ² /g	0.3 - 0.6 μm	
312013	Sc6Al1SZ TC Grade	$(Sc_2O_3)_{0.06}(Al_2O_3)_{0.01}(ZrO_2)_{0.93}$	8 - 10 m ² /g	0.5 - 0.7 μm	
312014	Sc10Al1SZ TC Grade	$(Sc_2O_3)_{0.10}(Al_2O_3)_{0.01}(ZrO_2)_{0.89}$	8 - 12 m ² /g	0.5 - 0.7 μm	

Cathode Powders

CATHODE POWDERS

We offer Sr-doped Lanthanum Manganite (LSM) in both standard and custom formulations. We also offer a line of Perovskite electrode materials based on Strontium and Cobalt doped Lanthanum Ferrite (LSCF), which offer improved low-temperature performance for SOFCs. Composite cathodes are used to extend the three-phase boundary region of the electrode/electrolyte interface and enhance oxygen reduction on the cathode. This improved activity reduces overall electrode and cell resistance.

- We have the ability to make material in larger quantities upon request.
- Tailored formulations and/or physical specification changes are available.



P/N	PRODUCT NAME	FORMULATION	SURFACE AREA	PSD (d50)	QUANTITIES
121101	LSM20-P	$(La_{0.80}Sr_{0.20})_{0.95}MnO_{3-x}$	4 - 8 m ² /g	0.3 - 0.6 μm	150 g 500 g 1 kg 5 kg
121205	LSCF-P	$(La_{0.60}Sr_{0.40})_{0.95}Co_{0.20}Fe_{0.80}O_{3-x}$	4 - 8 m ² /g	0.7 - 1.1 μm	
121601	LSC-P	$(La_{0.80}Sr_{0.20})_{0.95}CoO_{3-x}$	13 - 18 m ² /g	0.4 - 1.0 μm	
121701	LNC-P	$La_{0.95}Ni_{0.60}Co_{0.40}O_{3-x}$	4 - 8 m ² /g	0.7 - 1.1 μm	
122101	LSMGDC-P	50 wt% $(La_{0.80}Sr_{0.20})_{0.95}MnO_{3-x}$ 50 wt% $(Ce_{0.9}Gd_{0.1})O_{1.95}$	3 - 7 m ² /g	-	
122102	LSMYSZ-P	50 wt% $(La_{0.8}Sr_{0.2})_{0.95}MnO_{3-x}$ 50 wt% $(Y_{2}O_{3})_{3/0.08}(ZrO_{2})_{2/0.92}$	5 - 9 m ² /g	-	
122201	LSCFGDC-P	50 wt% $(La_{0.60}Sr_{0.40})_{0.95}(Co_{0.20}Fe_{0.80})O_{3-x}$ 50 wt% $(Ce_{0.9}Gd_{0.1})O_{1.95}$	3 - 7 m ² /g	-	

PREMIUM CATHODE POWDERS

Premium grade cathode powders are designed to provide high performance materials with wide processing flexibility. Premium Powders provide lab researchers with the confidence that their research has a foundation in proven, industrially scaled and traceable powders, while providing developers and manufacturers with scalable high quality powders to aid in commercialization.

- Industry-standard material formulations to provide high end performance and a baseline for materials development and optimization studies.
- Tailored for enhanced sinterability, and lower processing temperatures to provide you with the widest possible processing options.
- Batch-to-batch reproducibility and traceability.
- Industry leading characterization and reporting to speed your research and development cycles.



P/N	PRODUCT NAME	FORMULATION	SURFACE AREA	PSD (d50)	QUANTITIES
121103	LSM20 Premium	$(\text{La}_{0.80}\text{Sr}_{0.20})_{0.95}\text{MnO}_{3-x}$	10.0 - 14.0 m ² /g	0.10 - 0.50 μm	500 g
121203	LSCF Premium	$(\text{La}_{0.60}\text{Sr}_{0.40})_{0.95}\text{Co}_{0.20}\text{Fe}_{0.80}\text{O}_{3-x}$	10.0 - 14.0 m ² /g	0.10 - 0.50 μm	1 kg 5 kg

Anode Powders

NICKEL BASED ANODE POWDERS

Our anode materials range from the conventional compositions of NiO/Yttrium-stabilized Zirconia compositions to NiO composites with Gadolinium or Samarium doped Ceria. These anode formulations are optimized to create highly catalytic active anode layers. Other powders have been tailored to provide highly conductive current collection layers that provide stable gas diffusion during operation.

- Applications range from tape casting, extrusion, or roll compaction.
- Anode powders can quickly be processed into inks for screen printing of the anode electrode.
- Optimized particle sizes to control the pore structure of the fired material creating structures that are strong with high performance.
- The use of pre-formulated anode powder mixtures saves processing time and assures batch-to-batch reproducibility.



P/N	PRODUCT NAME	FORMULATION	SURFACE AREA	PSD (d50)	QUANTITIES
131101	NiGDC-P	60% NiO 40% GDC-10 by wt	4 - 8 m ² /g	-	150 g 500 g 1 kg 5 kg
131201	NiSDC-P	60% NiO 40% SDC-20 by wt	4 - 8 m ² /g	-	
131301	NiYSZ-P	66% NiO 34% YSZ-8 by wt	4 - 8 m ² /g	-	
132301	NiYSZ TC Grade	60% NiO 40% YSZ-8 by wt	1 - 4 m ² /g	-	
312010	NiO Fine Grade	NiO	2 - 5 m ² /g	0.5 - 1.5 μm	
312011	NiO Standard Grade	NiO	< 1 m ² /g	12 - 22 μm	

Inks

We offer contact inks for both the anode and cathode electrodes of SOFCs. To achieve quality results it is very important to have good contact between the electrode surface and the current collector. Applying a thin layer of ink (LSM or LSCF for the cathode and Nickel for the anode) over your electrode will help to ensure high quality reproducible results.

- We have the ability to make material in larger quantities upon request.
- Custom formulations and/or physical specification changes are available.



CATHODE INKS

P/N	PRODUCT NAME	FORMULATION	SOLIDS CONTENT	VISCOSITY (at 10/s)	QUANTITIES
232101	LSM20-I	$(\text{La}_{0.80}\text{Sr}_{0.20})\text{MnO}_{3-x}$	62 - 72%	15 - 40 Pa.s	100 g 500 g 1 kg 5 kg
232103	LSMYSZ-I	50 wt% $(\text{La}_{0.80}\text{Sr}_{0.20})\text{MnO}_{3-x}$ 50 wt% $(\text{Y}_{2/3}\text{O}_{3/0.08})(\text{ZrO}_2)_{0.92}$	60 - 70%	15 - 40 Pa.s	
232201	LSCF-I	$(\text{La}_{0.60}\text{Sr}_{0.40})(\text{Co}_{0.20}\text{Fe}_{0.80})\text{O}_{3-x}$	62 - 72%	15 - 40 Pa.s	
232202	LSCFGDC-I	50 wt% $(\text{La}_{0.60}\text{Sr}_{0.40})(\text{Co}_{0.20}\text{Fe}_{0.80})\text{O}_{3-x}$ 50 wt% $(\text{Ce}_{0.9}\text{Gd}_{0.1})\text{O}_{1.95}$	65 - 75%	15 - 40 Pa.s	
311006	VEH Ink Vehicle	Terpineol based	-	-	

This terpineol based ink vehicle is excellent for creating ceramic inks and is used in our own fabrication processes. You can also adjust the viscosity of your current inks by gradually adding this ink vehicle until you get the right consistency for your application.

ANODE INKS

Our Nickel ink is an excellent contact paste for SOFC testing, and is especially good for enhancing the electrical contact on the anode side of a cell during fuel cell testing. The Nickel ink can also be used as a reference electrode.



P/N	PRODUCT NAME	FORMULATION	SOLIDS CONTENT	QUANTITIES
231001	Nickel Ink Ni-I	-	75-80% Ni by weight	50 g
321004	Nickel YSZ Ink NIYSZ-I	66% NiO 34% YSZ8 by weight	73-77% by weight	100 g 500 g 1 kg 5 kg

PRECIOUS METAL INKS

We offer three different precious metal inks to assist in attaching current collector meshes to both anode and electrolyte supported cells. All precious metal inks should be used sparingly to ensure gas flow to the electrodes.

- Silver ink is best used for low temperature applications.
- Both gold and platinum work well at higher temperature testing.
- Nickel paste is an effective anode current collector.



P/N	PRODUCT NAME	SOLIDS CONTENT	QUANTITIES
233001	Gold Ink AU-I	Minimum 70% Au by weight	10 g
233002	Platinum Ink PT-I	Minimum 70% Pt by weight	10 g
321201	Silver Ink AG-I	Minimum 70% Ag by weight	10 g

Cells and Substrates

ELECTROLYTE SUPPORTED CELLS AND SINGLE-SIDED CELLS

The NextCell™ uses the patent-pending Hionic™ electrolyte support which is more than four times stronger than the most popular fully stabilized YSZ-8 material, with conductivity surpassing that of YSZ-8. Improved flexibility makes the cells less brittle and therefore more forgiving during operations such as testing and stack assembly.

- Electrolyte supported cells have high structural integrity and fuel utilization while offering simple sealing.
- Custom sizes and shapes are available upon request.
- Single sided cells work very well as an aid for researching electrode compositions.
- The NextCell™ uses a 150 µm (+/- 15 µm) Hionic™ electrolyte with 50 µm multi-layer electrodes.



P/N	PRODUCT NAME	SIZE	TYPE	QUANTITIES
212101	SECC-2.0	20 mm Ø	Cathode Only	Min. 5 pcs
212102	SECC-2.5	25 mm Ø	Cathode Only	
212201	SECA-2.0	20 mm Ø	Anode Only	
212202	SECA-2.5	25 mm Ø	Anode Only	
213201	NEXTCELL-10	100 x 100 mm ²	Full Cell	
213202	NEXTCELL-5	50 x 50 mm ²	Full Cell	
213205	NEXTCELL-2.0	20 mm Ø	Full Cell	
213206	NEXTCELL-2.5	25 mm Ø	Full Cell	
213209	NEXTCELL-7	28 cm ²	Full Cell	

ANODE SUPPORTED CELLS AND BI-LAYERS

Anode supported cells with the Ni-YSZ/YSZ/LSM structure are the most common starting point for intermediate temperature SOFC research and development. Thin electrolytes enhance ionic transport, especially below 800°C. Ni-YSZ anodes and LSM-based cathodes offer excellent catalytic performance and electronic transport.

- Optimal balance of membrane and ionic function using ~10 micrometer thick electrolyte.
- Small and large quantities available to meet R&D budgets.
- Cells and anode-electrolyte bilayers are offered for benchmarking, gas-contaminant performance and cathode material research.

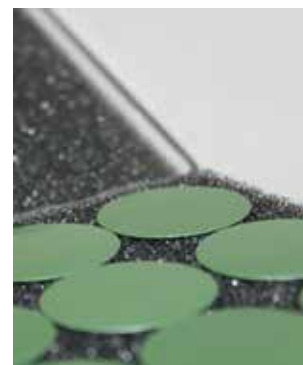

P/N	PRODUCT NAME	SIZE	TYPE	QUANTITIES
213307	ASC-5	50 x 50 mm ²	Anode supported planar cell	Min. 5 pces
313005	AEB-2.0	20 mm Ø	Anode electrolyte button bi-layer	
313006	AEB-2.5	25 mm Ø	Anode electrolyte button bi-layer	
313007	AEB-5	50 x 50 mm ²	Anode electrolyte planar bi-layer	

ELECTROLYTE SUBSTRATE BUTTONS

Using proprietary fabrication methods and materials, we have developed a high strength and high performance electrolyte support. The Hionic™ substrate is more than four times stronger than conventional fully stabilized YSZ-8 electrolyte supports. This high strength allow for thin substrates to be significantly more robust during handling, mounting and processing.

- High conductivity combined with the thinness of the support minimizes the overall resistance of the Hionic™ platform, thus improving the ability to measure the properties of electrodes and cells.
- Perfect starting point for the researcher who wants to test a variety of anode and cathode materials in SOFC development.
- YSZ-8 (8 mole % Ytria) are a low cost option when low performance is acceptable.



P/N	PRODUCT NAME	SIZE	TYPE	QUANTITIES
211201	HIONIC-2.0	20 mm Ø	Substrate	Min. 5 pces
211202	HIONIC-2.5	25 mm Ø	Substrate	
211101	YSZ-2.0	20 mm Ø	Substrate	
211102	YSZ-2.5	25 mm Ø	Substrate	
211103	YSZ-3.2	32 mm Ø	Substrate	
211212	HIONIC-5	50 x 50 mm ²	Substrate	
211211	HIONIC-10	100 x 100 mm ²	Substrate	

Seal Materials

COMPRESSION SEAL SHEETS AND HIGH TEMPERATURE SEAL PASTE

We offer two different types of seals, two versions of compression seals and one sealant paste. Compression seals are great for use with planar cells both anode and electrolyte supported. The high temperature sealing paste works with both planar and tubular designs.

- Compression seals are made from both Alumina and Mica.
- Alumina Slurry can be used as an additive to the Alumina felt to increase sealing properties.
- Custom sizes or shapes are available upon request.



P/N	PRODUCT NAME	SIZE	THICKNESS	DESCRIPTION	QUANTITIES
321109	ALSL	-	-	Alumina Slurry	50 ml
321101	AFS-100	100 x 100 mm ²	1.0 mm	Alumina Felt	5 sheets
321102	AFS-170	170 x 170 mm ²	1.0 mm	Alumina Felt	5 sheets
321111	MPS-100-25	100 x 100 mm ²	0.25 mm	Flexible Mica Paper	10 sheets
321112	MPS-100-50	100 x 100 mm ²	0.50 mm	Flexible Mica Paper	10 sheets
321113	MPS-170-25	170 x 170 mm ²	0.25 mm	Flexible Mica Paper	10 sheets
321114	MPS-170-50	170 x 170 mm ²	0.50 mm	Flexible Mica Paper	10 sheets
321121	CAP-552	-	-	High Temperature SOFC Sealing Paste	475 ml

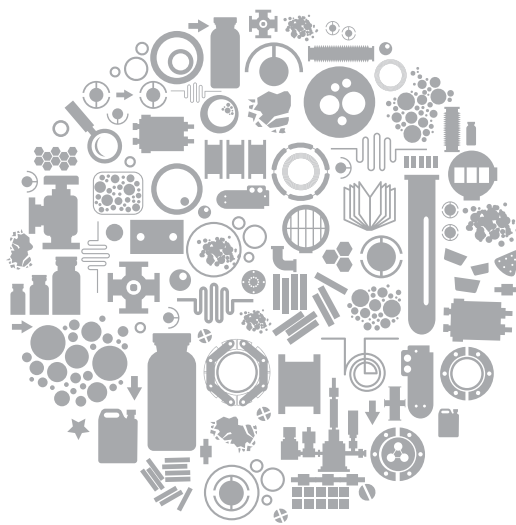

neyco

30 avenue de la Paix
92170 Vanves - France
Tel: +33(0)1 41 90 50 50
Fax: +33(0)1 41 90 50 51

www.neyco.fr



Materials G 2018-1

neyco



MATERIALS

CRUCIBLES, LINERS & Cones

- Liners..... H 03
- Evaporation Cones..... H 05
- Crucible Liners Selection Table..... H 06

H

Crucible liners protect the water-cooled copper hearth in electron beam units and eliminate the risk of contamination when one material replaces another in a given pocket. They also minimize heat transfer between the evaporated material and the water-cooled crucible. They reduce time of clean up and material changes and help increase deposition rates.

Liners can be manufactured from Graphite, Molybdenum, Tantalum and most other metals as well as from Al_2O_3 , BN and other non-metals. The choice of the liners depends on the material to be evaporated.



Liners

LINERS

DIMENSIONS

DESIGNATION	DIMENSIONS in mm		ANGLE
	UPPER DIAMETER	HEIGHT	
4 cc crucible	22.48	14.61	15°
7 cc crucible	29.64	14.30	15°
15 cc crucible	37.59	17.02	15°
25 cc crucible (4 pockets)	46.99	17.27	15°
40 cc crucible	50.80	26.97	15°
40 cc crucible	51.56	25.91	15°

Other dimensions on request.

ORDER PART NUMBERS

To determine correct model Number

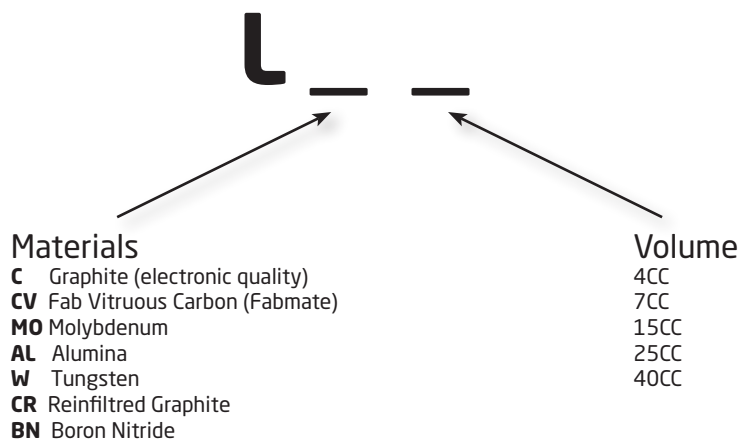

* for 25 cc liners, indicate the number of pockets 4 or 6 as follow:

L4_25CC
L5_25CC

Exemples: Liner 7 cc Fabmate: LCV7CCFAB

Liner 4 cc Molybdenum: LMO4CC

Liner 25 cc 4 pockets Graphite: L4C25CC

Others sizes (13 cc, 18 cc, 30 cc, 156 cc...) and materials (Intermetallic, Copper, Tantalum...) on request.

All NEYCO Graphite crucibles and liners are *Electronic Quality* - ashes < 5 ppm -

OTHER E-BEAM LINERS

Neyco supplies crucible liners for Leybold, Edwards, Satis, Thermionics, Varian, CHA Industries, MDC electron beam guns. All sizes and materials on request.

Evaporation Cones

Neyco supplies pre-melted evaporation cones for all electron beam guns:

- Metals, alloys, (Ni, Ni/Cr, Al, Cr, Si...)
- From 99 to 99.999%
- Supplied with certificate of analysis

Neyco supplies also reducers cone in metals (Cu, Mo, W...) to reduce the volume of the pocket and/or to be compatible with existing liners.

All sizes and materials on request.

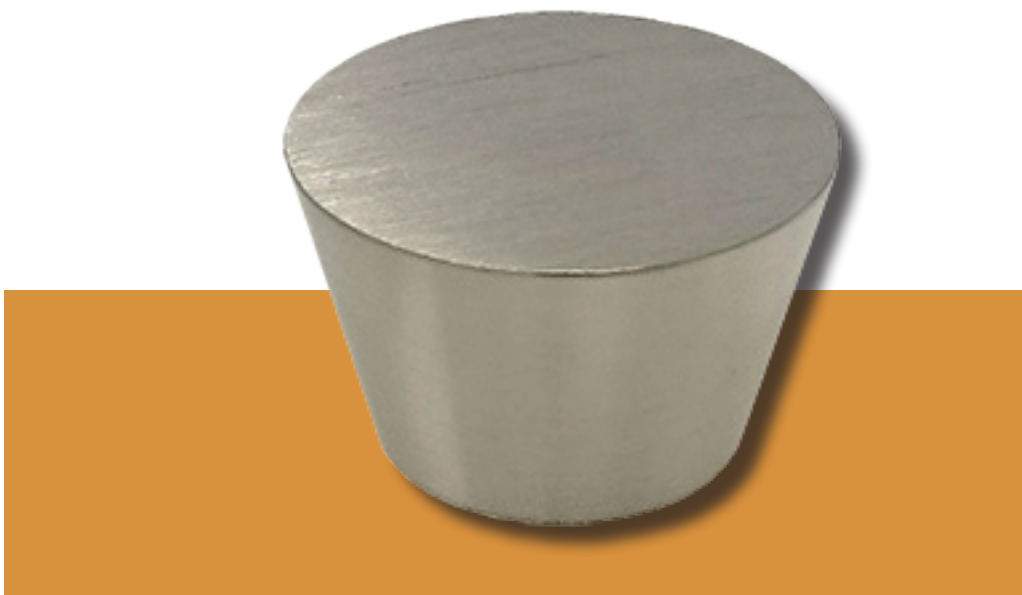

Crucible Liners Selection Table

EVAPORATION MATERIAL	LINERS							
	C	VC	Al ₂ O ₃	BN	Mo	Ta	Int	W
Aluminum Al	•						•	
Aluminum Fluoride AlF ₃	•							
Aluminum 2% Silicon Al/Si	•						•	
Antimony Sb	•		•	•				
Antimony Oxide Sb ₂ O ₃			•	•				
Antimony Sulfide Sb ₂ S ₃			•					
Arsenic As	•	•	•					
Arsenic Sulfide As ₂ S ₃					•			
Barium Oxide BaO			•					
Beryllium Be	•	•						
Bismuth Bi		•	•					
Bismuth Selenide BiSe ₃	•							
Bismuth Telluride BiTe ₃	•							
Cadmium Cd			•					
Cadmium Selenide CdSe			•					
Cadmium Sulfide CdS	•		•					
Calcium Ca			•					
Cerium Ce		•	•					
Cerium Oxide CeO ₂	•							
Chromium Cr	•	•						
Cobalt Co			•					
Copper Cu	•		•		•	•		
Copper Oxide Cu ₂ O			•					
Cryolite Na ₃ AlF ₆	•	•						
Europium Eu			•					
Europium Oxide EuO ₃								•
Gadolinium Gd			•					
Gallium Ga	•	•	•					
Gallium Arsenide GaAs	•							

EVAPORATION MATERIAL	LINERS							
	C	VC	Al ₂ O ₃	BN	Mo	Ta	Int	W
Germanium Ge	•		•					
Germanium Oxide GeO ₂		•	•					
Gold Au	•	•	•	•				
Indium In	•		•		•			
Indium Oxide In ₂ O ₃			•					
Iridium Ir								•
Iron Fe		•	•					
Lanthanum La			•					
Lead Pb	•		•					
Lithium Li			•					
Lithium Fluoride LiF			•					
Lutetium Lu			•					
Magnesium Mg		•	•					
Magnesium Fluoride MgF ₂			•					
Magnesium Oxide MgO	•		•					
Manganese Mn			•					
Molybdenum Mo	•							
Molybdenum Oxide MoO ₃			•		•			
Neodymium Nd			•					
Neodymium Fluoride NdF ₃			•					
Neodymium Oxide Nd ₂ O ₃								•
Nichrome IV Ni/Cr	•	•	•					
Nickel Ni		•	•					
Nickel Oxide NiO			•					
Palladium Pd	•		•					
Palladium Oxide PdO			•					
Permalloy Ni/Fe		•	•					
Platinum Pt	•							•
Praseodymium Oxide Pr ₂ O ₃								•
Rhodium Rh		•						•
Samarium Sm			•					
Samarium Oxide Sm ₂ O ₃								•
Scandium Sc			•					
Selenium Se	•	•	•					
Silicon Si		•				•		
Silicon Dioxide SiO ₂	•		•					
Silicon Monoxide SiO	•					•		
Silver Ag	•	•	•		•			
Strontium Sr		•						
Tantalum Ta	•							
Tantalum Oxide Ta ₂ O ₅		•						
Tellurium Te	•	•	•					
Terbium Tb			•					
Thallium Tl			•					
Thorium Fluoride ThF ₄		•						
Thulium Tm			•					
Tin Sn	•		•					

EVAPORATION MATERIAL	LINERS							
	C	VC	Al ₂ O ₃	BN	Mo	Ta	Int	W
Tin Oxide SnO ₂			•					
Titanium Ti	•							
Titanium Oxide TiO	•	•						
Yttrium Y			•					
Yttrium Oxide Y ₂ O ₃	•							
Zinc Zn			•					

C = Graphite, **VC** = Vitreous Carbon, **BN** = Boron Nitride, **Int** = Intermetallic (BN + TiB₂).
 All given data are indicative and may need to be adapted to your process.

 See Section C - Pellets in this catalogue about evaporation materials.

 See Section M - Vacuum Deposition Equipment in this catalogue about E-Guns and E-Guns parts.

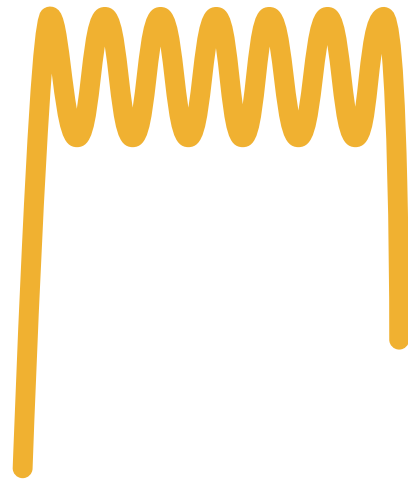

MATERIALS

EVAPORATION

SOURCES

- Evaporation Source Selection Guide | 02
- Tungsten Filaments for Vacuum Metalizing..... | 04
- Tungsten Rod Source | 07
- Point Source Loop Filaments..... | 08
- Heater Filaments | 10
- Baskets | 11
- Alumina Coated Baskets | 14
- Crucibles | 15
- Heat Shielded Crucible Heaters | 17
- Boat Sources | 20
- Folded Boats | 32
- Alumina Coated Evaporation Sources..... | 34
- Special Tantalum Boats..... | 40
- Folded Baffled Box Sources | 44
- Baffled Box Sources for SiO, ZnS | 46
- Microelectronic Sources Tungsten -
Tantalum - Molybdenum | 52
- Chrome Plated Tungsten Rods | 57

Evaporation Source Selection Guide

This source selection guide is provided to help you determine which evaporation source type might fit your needs.

How to use the Guide:

1. Determine how much current your power supply is capable of safely producing.
2. Establish the vapor temperature of the material(s) you plan on evaporating.
3. Estimate the coating thickness you will be attempting. With the information shown in the following table, you can select which part types will best meet your needs.

As always, Neyco offers open technical support if you need further assistance in selecting the right evaporation source to make your thin film coating process a success.



EVAPORATION SOURCE TYPE	PROCESS CONDITIONS									
	LOW POWER <100 A	MEDIUM POWER 100-250 A	HIGH POWER >250 A	LOW TEMP MATERIALS <1000°C	HIGH TEMP MATERIALS >1000°C	CORROSIVE MATERIALS	LOW VOLUME MATERIALS	MEDIUM VOLUME COATING <1000 Å	HIGH VOLUME COATING 1000 Å - 5000 Å	REDUCE PARTICULATES FROM SPITTING
Tungsten Filament	•			•	•		•			
Tungsten Point Source	•			•	•		•			
Tungsten Basket	•			•	•		•			
Alumina Coated Basket	•			•	•	•	•	•		
Tungsten Basket Heater	•			•			•	•		
Shielded Crucible Heater			•	•	•	•	•	•	•	
Evaporation Boat		•	•	•	•	•	•	•		
Folded Boat		•	•	•	•	•	•	•	•	
Alumina Coated Boat		•	•	•	•	•	•	•		
Baffled Box Sources			•	•	•		•	•	•	•
Shielded Baffled Box Sources			•	•	•		•	•	•	•
Micro-Electronic Sources	•			•	•		•			
Chrome Plated Tungsten Rods	•				•		•	•		•

Tungsten Filaments for Vacuum Metalizing

Tungsten metalizing filaments have long been the standard for thin film depositions for a wide variety of materials. We offer an extensive selection of tungsten filaments to fit most applications as well as custom fabrication to meet your specific process needs. The benefits of using tungsten metalizing filaments for your evaporation process include low cost, long life, high rates with low power, repeatability and ease of use.

P/N	VOLTS	AMPS	WATTS	TEMP.
F1-.040W	3.07	36	111	1800°C
F1-3X.025W	3.00	42	126	1800°C
F1-3X.030W	2.94	54	159	1800°C

P/N	VOLTS	AMPS	WATTS	TEMP.
F2-3X.025W	3.43	49	168	1800°C
F2-3X.030W	3.08	63	194	1800°C
F2-4X.030W	2.70	77	208	1800°C

P/N	VOLTS	AMPS	WATTS	TEMP.
F3-.040W	3.91	39	152	1800°C
F3-2X.040W	4.00	68	272	1800°C
F3-3X.025W	4.61	48	221	1800°C
F3-3X.030W	4.15	60	249	1800°C
F3-4X.030W	4.00	77	308	1800°C

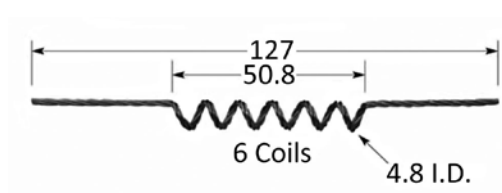
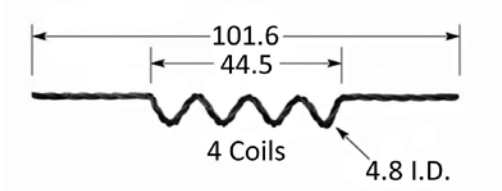
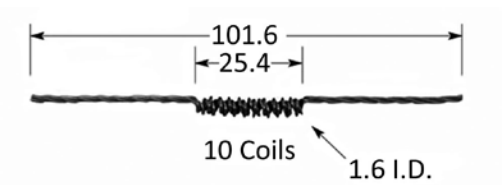

All dimensions are in mm.

P/N	VOLTS	AMPS	WATTS	TEMP.
F4-.040W	3.70	38	141	1800°C
F4-2X.040W	3.97	66	262	1800°C
F4-3X.025W	5.29	48	254	1800°C
F4-3X.030W	4.28	62	265	1800°C
F4-4X.030W	3.63	73	265	1800°C

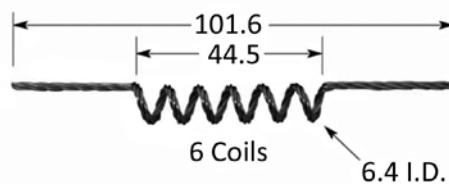

P/N	VOLTS	AMPS	WATTS	TEMP.
F5-.040W	6.90	37	255	1800°C
F5-2X.040W	6.82	64	436	1800°C
F5-3X.025W	8.05	45	362	1800°C
F5-3X.030W	6.58	57	375	1800°C
F5-3X.040W	5.60	83	465	1800°C
F5-4X.030W	6.10	69	421	1800°C

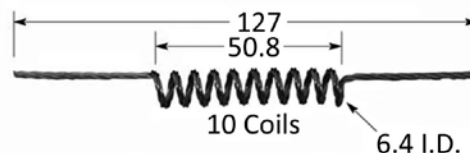

P/N	VOLTS	AMPS	WATTS	TEMP.
F6-2X.040W	7.20	64	461	1800°C
F6-3X.025W	8.72	44	384	1800°C
F6-3X.030W	8.25	58	478	1800°C
F6-3X.040W	6.42	84	539	1800°C
F6-4X.030W	7.29	71	518	1800°C

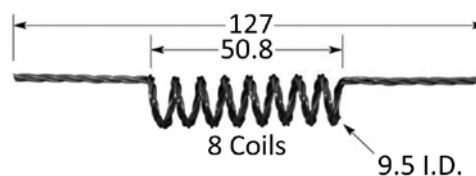

P/N	VOLTS	AMPS	WATTS	TEMP.
F7-2X.040W	10.97	55	603	1800°C
F7-3X.030W	11.65	52	606	1800°C
F7-3X.040W	9.40	78	733	1800°C
F7-4X.030W	10.31	65	670	1800°C

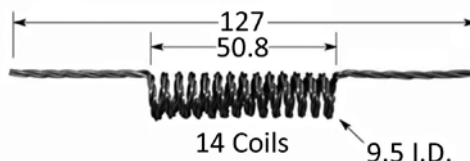

P/N	VOLTS	AMPS	WATTS	TEMP.
F8-2X.040W	5.00	66	330	1800°C
F8-3X.030W	5.39	62	334	1800°C
F8-3X.040W	4.61	87	401	1800°C
F8-4X.030W	5.09	74	377	1800°C

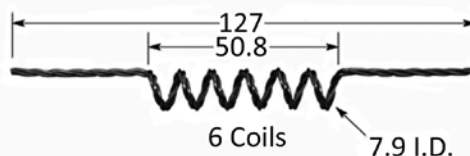

P/N	VOLTS	AMPS	WATTS	TEMP.
F9-2X.040W	6.66	65	433	1800°C
F9-3X.030W	6.50	57	370	1800°C
F9-3X.040W	5.43	86	467	1800°C
F9-4X.030W	6.07	71	431	1800°C

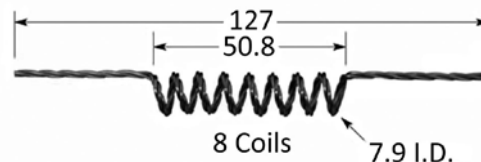

P/N	VOLTS	AMPS	WATTS	TEMP.
F10-2X.040W	10.62	61	648	1800°C
F10-3X.030W	10.90	55	600	1800°C
F10-3X.040W	9.02	83	749	1800°C
F10-4X.030W	10.00	68	680	1800°C

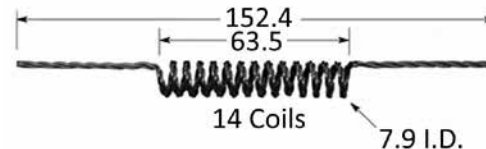

All dimensions are in mm.

P/N	VOLTS	AMPS	WATTS	TEMP.
F11-2X.040W	6.74	65	438	1800°C
F11-3X.030W	7.07	58	410	1800°C
F11-3X.040W	5.70	87	496	1800°C
F11-4X.030W	6.40	70	448	1800°C

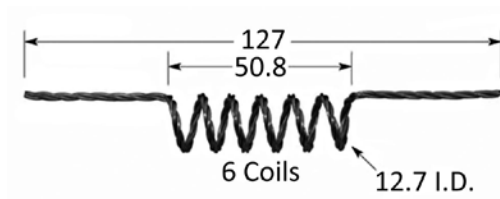

P/N	VOLTS	AMPS	WATTS	TEMP.
F12-3X.025W	4.44	46	204	1800°C
F12-3X.030W	3.82	57	218	1800°C

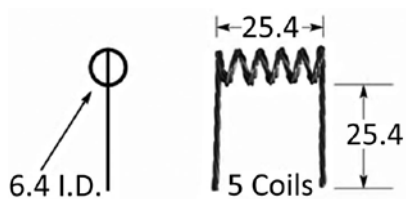

P/N	VOLTS	AMPS	WATTS	TEMP.
F13-3X.025W	11.00	44	484	1800°C
F13-3X.030W	9.06	57	516	1800°C
F13-4X.030W	8.59	71	610	1800°C

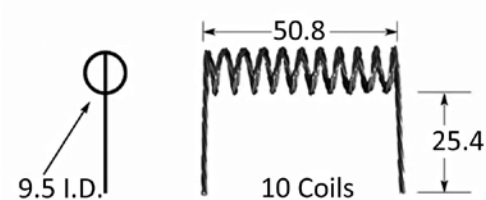

P/N	VOLTS	AMPS	WATTS	TEMP.
F14-3X.030W	9.44	56	529	1800°C
F14-3X.040W	8.20	88	722	1800°C
F14-4X.030W	8.80	68	598	1800°C

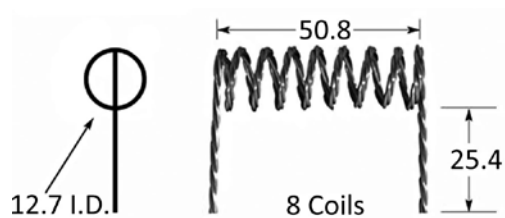

P/N	VOLTS	AMPS	WATTS	TEMP.
F15-3X.030W	11.53	57	657	1800°C
F15-3X.040W	9.66	85	821	1800°C
F15-4X.030W	10.63	70	744	1800°C

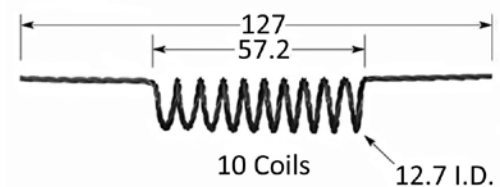

W: Tungsten.

All dimensions are in mm.

Tungsten Rod Source

P/N	VOLTS	AMPS	WATTS	TEMP.
F16A	1.12	148	166	1500°C
F16B	1.19	149	177	1500°C
F16C	1.30	172	224	1500°C
F16D	3.62	223	807	1500°C

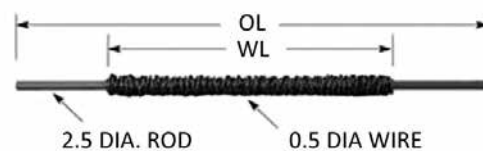

P/N	OL	WL	WRAP LAYERS
F16A	4	2	8
F16B	5	3	8
F16C	5	3	12
F16D	8	6	12

All dimensions are in mm.

Point Source Loop Filaments

P/N	VOLTS	AMPS	WATTS	TEMP.
P1-.060W	2.08	73	152	1800°C
P1-3X.025W	2.95	50	148	1800°C
P1-3X.030W	2.36	65	153	1800°C
P1-4X.030W	2.76	80	221	1800°C

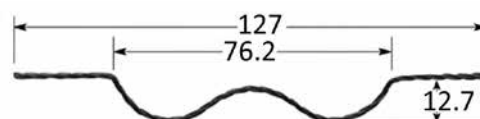

P/N	VOLTS	AMPS	WATTS	TEMP.
P2-.060W	1.84	75	138	1800°C
P2-3X.025W	2.83	48	136	1800°C
P2-3X.030W	3.56	78	278	1800°C
P2-4X.030W	2.04	82	167	1800°C

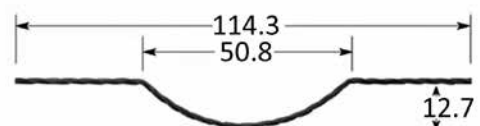

P/N	VOLTS	AMPS	WATTS	TEMP.
P3-.060W	1.39	79	110	1800°C
P3-3X.025W	2.26	50	113	1800°C
P3-3X.030W	1.94	64	124	1800°C
P3-4X.030W	1.59	84	134	1800°C

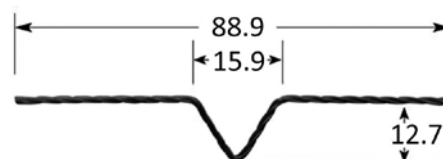

P/N	VOLTS	AMPS	WATTS	TEMP.
P4-.060W	2.04	74	151	1800°C
P4-3X.025W	3.20	51	163	1800°C
P4-3X.030W	2.04	64	131	1800°C
P4-4X.030W	2.69	80	215	1800°C

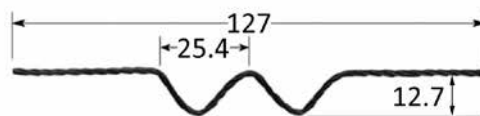

All dimensions are in mm.

P/N	VOLTS	AMPS	WATTS	TEMP.
P5-.040W	3.44	40	138	1800°C
P5-.060W	3.09	71	219	1800°C
P5-3X.025W	3.80	51	194	1800°C
P5-3X.030W	3.50	66	231	1800°C
P5-4X.030W	3.13	79	247	1800°C

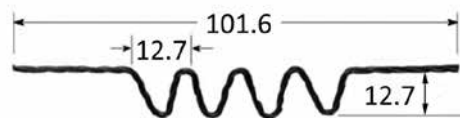

P/N	VOLTS	AMPS	WATTS	TEMP.
P6-.040W	1.94	42	81	1800°C
P6-.060W	1.46	75	109	1800°C
P6-3X.025W	2.08	51	106	1800°C

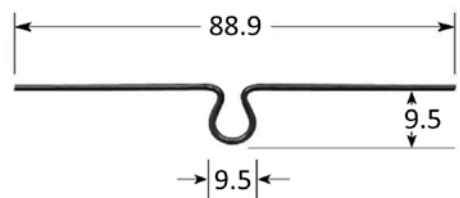

P/N	VOLTS	AMPS	WATTS	TEMP.
P7-3X.030W	2.78	69	192	1800°C
P7-4X.030W	2.42	87	211	1800°C

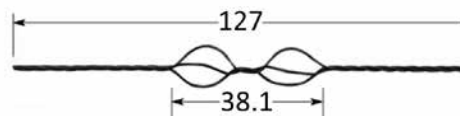

P/N	VOLTS	AMPS	WATTS	TEMP.
P8-3X.025W	9.48	54	512	1800°C
P8-3X.030W	8.28	72	596	1800°C

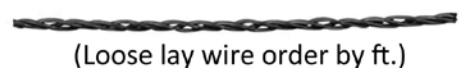

W: Tungsten.

All dimensions are in mm.

Heater Filaments

P/N	VOLTS	AMPS	WATTS	TEMP.
H1-.040W	7.90	31	245	1800°C
H1-.060W	6.10	71	433	1800°C

P/N	VOLTS	AMPS	WATTS	TEMP.
H2-.040W	4.18	36	150	1800°C
H2-.060W	2.83	69	195	1800°C

P/N	VOLTS	AMPS	WATTS	TEMP.
H3-.040W	7.39	34	251	1800°C
H3-.060W	5.22	63	329	1800°C

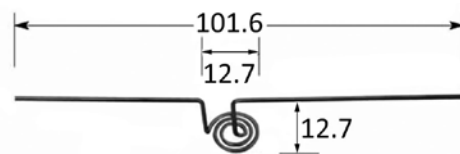
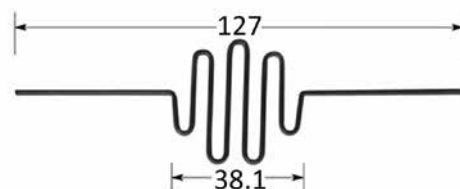

Note: .060W has one less turn

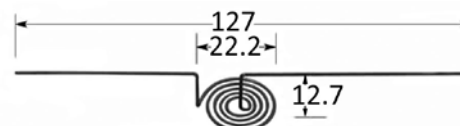

Note: .060W has two less turns

W: Tungsten.

All dimensions are in mm.

Baskets

Tungsten Evaporation Baskets offer an effective method of reaching high temperatures with low current. The benefits of using tungsten baskets as an evaporation source for your deposition process include low cost, ease of use, multi-directional coatings and low power requirements. Custom fabrication, to meet your specific process needs, is available upon request.

P/N	VOLTS	AMPS	WATTS	TEMP.
B1-.040W	3.47	34	118	1800°C
B1-3X.025W	4.22	43	181	1800°C
B1-3X.030W	3.69	53	196	1800°C

P/N	VOLTS	AMPS	WATTS	TEMP.
B2-.040W	3.04	36	109	1800°C
B2-3X.025W	3.50	44	154	1800°C
B2-3X.030W	3.00	54	162	1800°C

P/N	VOLTS	AMPS	WATTS	TEMP.
B3-.040W	5.40	33	178	1800°C
B3-3X.025W	3.51	42	147	1800°C

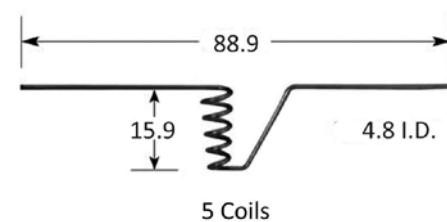
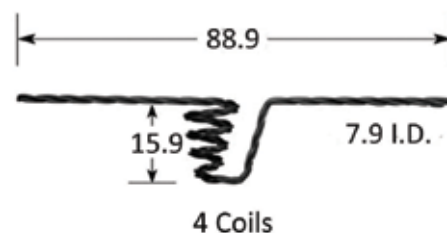
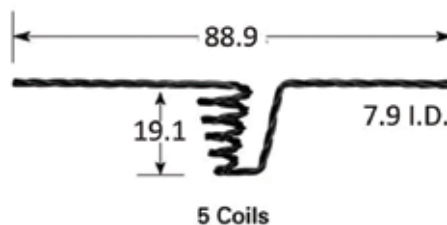

All dimensions are in mm.

P/N	VOLTS	AMPS	WATTS	TEMP.
B4-.060W	4.02	59	237	1800°C
B4-3X.030W	5.24	52	272	1800°C

P/N	VOLTS	AMPS	WATTS	TEMP.
B5-.040W	5.50	33	182	1800°C
B5-3X.025W	5.83	37	216	1800°C

P/N	VOLTS	AMPS	WATTS	TEMP.
B6-.040W	6.62	32	212	1800°C
B6-3X.025W	7.04	39	275	1800°C

P/N	VOLTS	AMPS	WATTS	TEMP.
B7-.040W	6.22	32	199	1800°C
B7-3X.025W	6.84	38	260	1800°C

P/N	VOLTS	AMPS	WATTS	TEMP.
B12A-.040W	5.00	37	185	1800°C
B12A-3X.025W	5.31	44	234	1800°C
B12A-3X.030W	4.80	55	264	1800°C

P/N	VOLTS	AMPS	WATTS	TEMP.
B12B-.040W	3.96	33	131	1800°C
B12B-.060W	2.54	99	251	1800°C
B12B-3X.025W	4.56	41	187	1800°C
B12B-3X.030W	3.17	57	181	1800°C

P/N	VOLTS	AMPS	WATTS	TEMP.
B13-.040W	3.22	37	119	1800°C
B13-3X.025W	4.04	45	182	1800°C
B13-3X.030W	3.36	57	192	1800°C

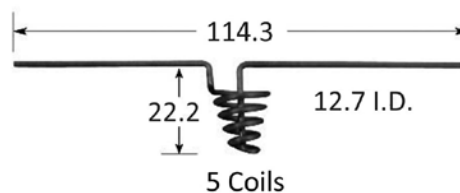

5 Coils

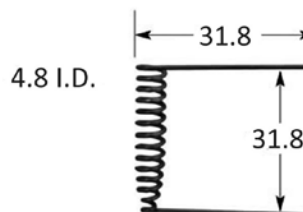

13 Coils

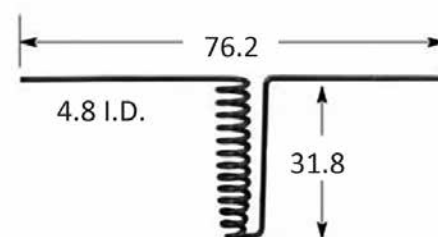

13 Coils

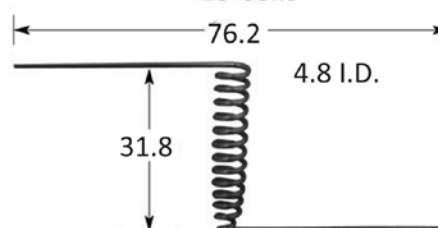

13 Coils

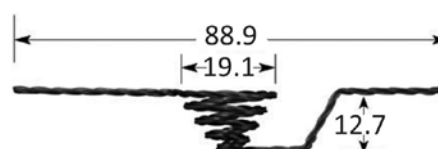

4 Coils



5 Coils

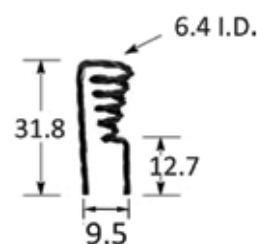

5 Coils

All dimensions are in mm.

P/N	VOLTS	AMPS	WATTS	TEMP.
B14-060W	4.83	54	261	1800°C
B14-3X.030W	6.25	50	312	1800°C
B14-4X.030W	5.82	62	361	1800°C

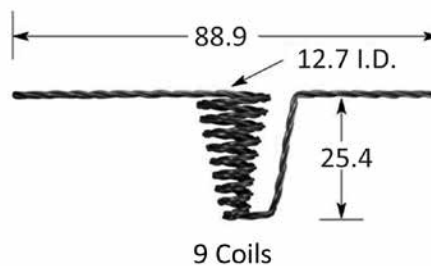

P/N	VOLTS	AMPS	WATTES	TEMP.
B8A-3X.025W	6.28	47	295	1800°C
B8A-3X.030W	6.06	55	333	1800°C
Use with C1 crucible				

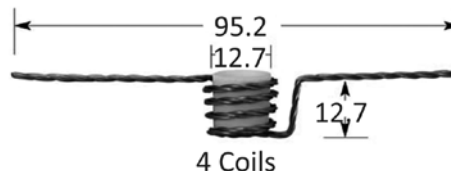

P/N	VOLTS	AMPS	WATTES	TEMP.
B8B-3X.025W	5.80	43	249	1800°C
B8B-3X.030W	5.15	57	294	1800°C
Use with C9 crucible				

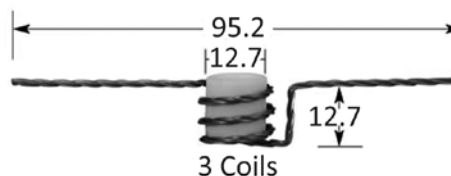

P/N	VOLTS	AMPS	WATTES	TEMP.
B9-3X.030W	8.42	57	480	1800°C
B9-3X.040W	7.18	85	610	1800°C
B9-4X.030W	7.76	70	543	1800°C
Use with C2 crucible				

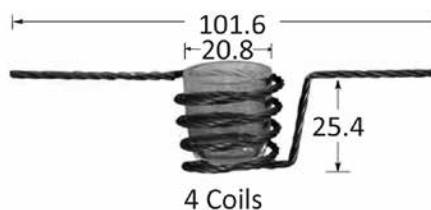

P/N	VOLTS	AMPS	WATTES	TEMP.
B10-3X.040W	8.73	85	742	1800°C
B10-4X.030W	9.76	71	693	1800°C
Use with C5 crucible				

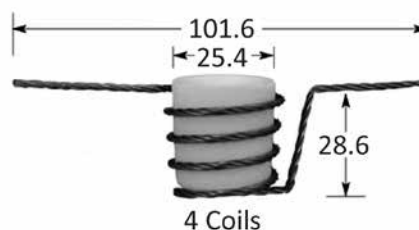

P/N	VOLTS	AMPS	WATTES	TEMP.
B11-3X.040W	19.70	84	1655	1800°C
Use with C6 crucible				

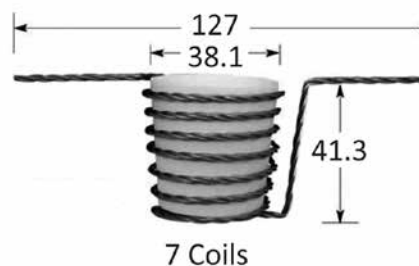

All dimensions are in mm.

Alumina Coated Baskets

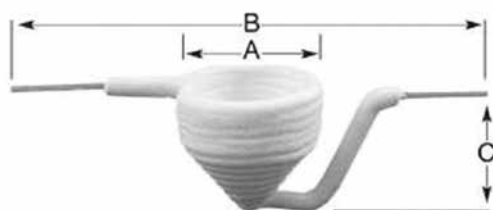

P/N	VOLTS	AMPS	WATTS	TEMP.	Ø WIRE	Ø, A	DEPTH	B	C
RDM-WBAO-1	5.7	11	63	1475°C	0.51	3.81	5.7	101.6	9.5
RDM-WBAO-2	6.2	40	248	1475°C	1.02	9.53	8.9	101.6	12.7
RDM-WBAO-3	6.9	39	272	1475°C	1.02	10.67	10.8	101.6	14.6
RDM-WBAO-4	13	33	429	1475°C	1.02	20.07	18.4	101.6	22.2
RDM-WBAO-5	7	50	450	1475°C	1.27	12.7	19.7	101.6	23.5
RDM-WBAO-6	15.8	49	768	1475°C	1.52	22.9	24.8	101.6	28.6

P/N	VOLTS	AMPS	WATTS	TEMP.
ME17-030W-AO	4.44	18	80	1200°C



W: Tungsten, **AO:** Alumina Oxide.

All dimensions are in mm.

Crucibles

We offer a wide variety of crucible sizes and materials for your evaporation needs. The crucibles shown in this section are designed to fit into our basket and crucible heaters. Custom sizes are available upon request. We also offer liners for electron beam systems.

P/N	FEATURES
C1-A0	Tapered Wall thickness = 1 mm Use with B8A basket Use with CH-1, CH-10, CH-11 and ME-19 Heaters
C1-BN	
C1-BNC	
C1-Q	

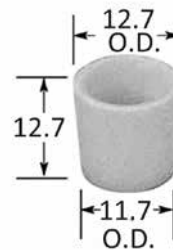

P/N	FEATURES
C2-Q	Tapered Wall thickness = 1.27 mm Use with B-9 Basket



P/N	FEATURES
C3-Q	Wall thickness = 1.78 mm

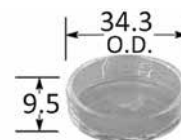

P/N	FEATURES
C4-C	Wall thickness = 2.29 mm
C4-M0	
C4-TA	



All dimensions are in mm.

P/N	FEATURES
C5-AO C5-BN C5-BNC C5-Q	Tapered Wall thickness = 1.52 mm Use with CH-5, CH-12 and CH-13 Heaters Use with B-10 Basket

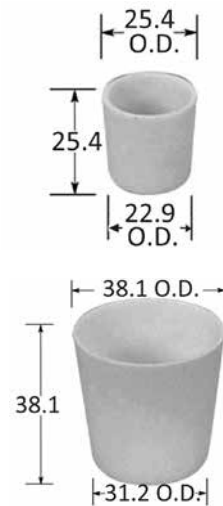

P/N	FEATURES
C6-AO C6-Q	Tapered Wall thickness = 1.78 mm Use with CH-6, CH-14 Heaters Use with B-11 Basket

P/N	FEATURES
C7-BN C7-C C7-MO C7-Q C7-TA	6.35 mm ID Susceptor type Use with CH-7 Heater



P/N	FEATURES
C8-BN C8-C C8-MO C8-Q C8-TA	9.53 mm ID Susceptor type Use with CH-8 Heater



P/N	FEATURES
C9-AO C9-BN C9-BNC C9-C C9-MO C9-Q C9-TA	Straight wall Wall thickness = 1 mm Use with CH-1, CH-10, CH-11, ME-19 Heaters and B8B, ME18B Baskets

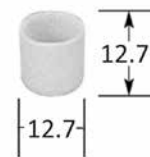

P/N	FEATURES
C10-BN C10-C C10-MO C10-Q C10-TA	3.97 mm ID Susceptor type Use with CH-9, ME-20 Heaters



AO: Alumina Oxide, **Q:** Quartz, **BN:** Boron Nitride,
BNC: BN+TiB₂, **TA:** Tantalum, **MO:** Molybdenum, **C:** Carbon.

All dimensions are in mm.

Heat Shielded Crucible Heaters

Shielded Crucible Heaters provide uniform heating to the installed crucible and allow very high rates as well as high temperatures, up to 1800°C, to be achieved. Due to the rigid construction, heater and crucible life is extended. The thermal shields protect your components by reducing the radiant heat that your system is exposed to. Custom sizes are available on request.

Material: Ta, Tantalum

P/N	VOLTS	AMPS	WATTS	TEMP.
CH-1	1.34	273	366	1600°C
Use with C1 and C9 crucibles				

P/N	VOLTS	AMPS	WATTS	TEMP.
CH-5	1.79	346	619	1600°C
Use with C5 crucible				

P/N	VOLTS	AMPS	WATTS	TEMP.
CH-6	1.9	395	751	1600°C
Use with C6 crucible				

P/N	VOLTS	AMPS	WATTS	TEMP.
CH-7	1.47	187	275	1600°C
Use with C7 crucible				

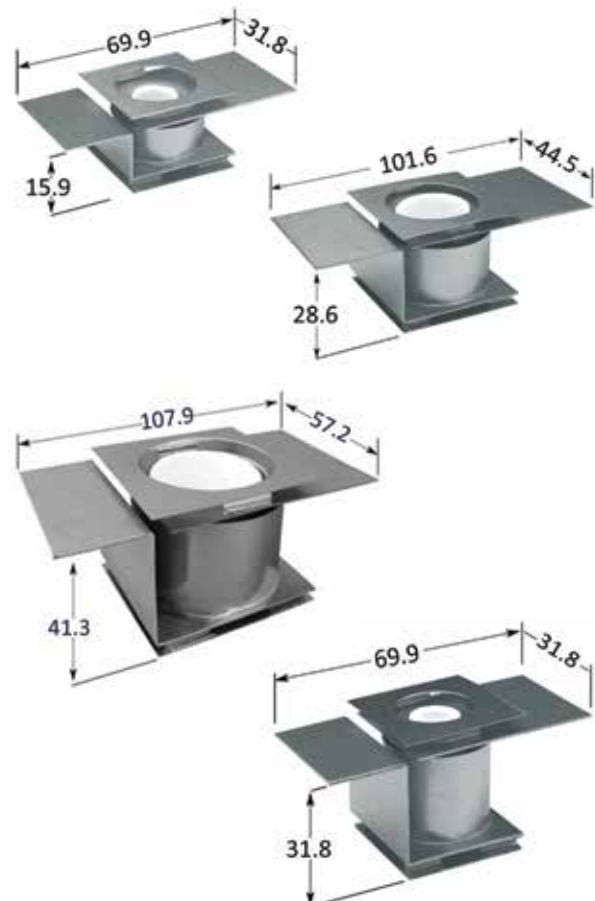

All dimensions are in mm.

P/N	VOLTS	AMPS	WATTS	TEMP.
CH-8	1.73	199	344	1600°C
Use with C8 crucible				



P/N	VOLTS	AMPS	WATTS	TEMP.
CH-9	1.93	191	369	1600°C
Use with C10 crucible				



P/N	VOLTS	AMPS	WATTS	TEMP.
CH-10	1.70	191	325	1600°C
Use with C1 and C9 crucibles (horizontal leads)				

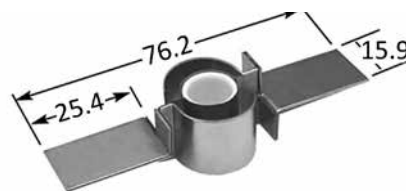

P/N	VOLTS	AMPS	WATTS	TEMP.
CH-11	1.70	191	325	1600°C
Use with C1 and C9 crucibles (vertical leads)				

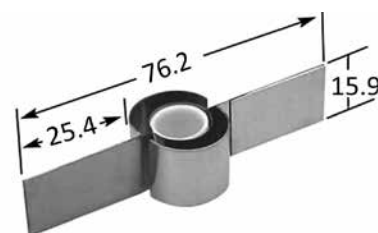

P/N	VOLTS	AMPS	WATTS	TEMP.
CH-12	2.19	339	742	1600°C
Use with C5 crucible (horizontal leads)				



P/N	VOLTS	AMPS	WATTS	TEMP.
CH-13	2.19	339	742	1600°C
Use with C5 crucible (vertical leads)				

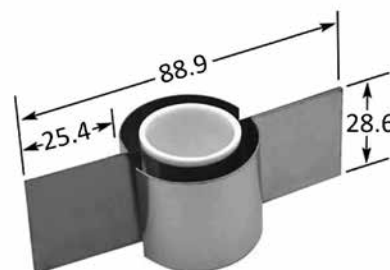

P/N	VOLTS	AMPS	WATTS	TEMP.
CH-14	3.82	525	2006	1600°C
Use with C6 crucible (horizontal leads)				

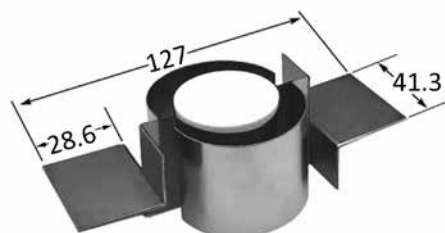

All dimensions are in mm.

P/N	VOLTS	AMPS	WATTS	TEMP.
ME-19	1.26	257	324	1600°C
Use with C1 and C9 crucibles				

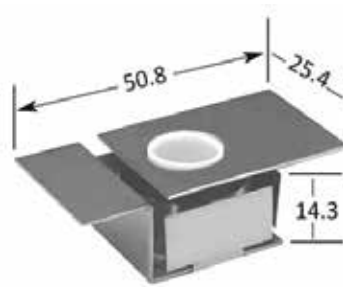

P/N	VOLTS	AMPS	WATTS	TEMP.
ME-20	1.16	169	196	1600°C
Use with C10 crucible				

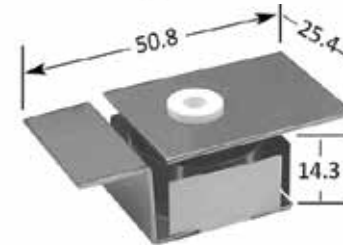

All dimensions are in mm.

Boat Sources

Evaporation Boats are capable of depositing a wide variety materials. We offer an extensive selection of standard tungsten boats, tantalum boats and molybdenum boats as well as custom fabrication to meet your specific evaporation source needs. All of our evaporation boats are available in a variety of high purity materials and thicknesses.

P/N	VOLTS	AMPS	WATTS	TEMP.
S1-.005Mo	1.29	63	81	1400°C
S1-.005Ta	2.72	64	174	1600°C
S1-.005W	2.25	101	227	1800°C
S1-.010Mo	0.96	96	92	1400°C
S1-.010Ta	1.91	96	183	1600°C
S1-.010W	1.79	144	258	1800°C
S1-.015W	1.50	184	276	1800°C

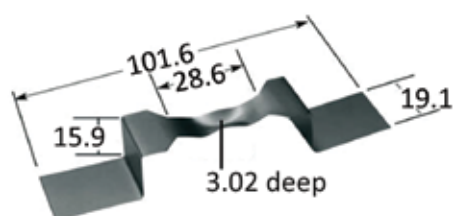

P/N	VOLTS	AMPS	WATTS	TEMP.
S2A-.005Mo	1.72	86	148	1400°C
S2A-.005Ta	3.37	100	337	1600°C
S2A-.005W	3.85	140	539	1800°C
S2A-.010Mo	1.13	130	147	1400°C
S2A-.010Ta	2.27	133	302	1600°C
S2A-.010W	2.57	185	475	1800°C
S2A-.015W	2.20	242	532	1800°C

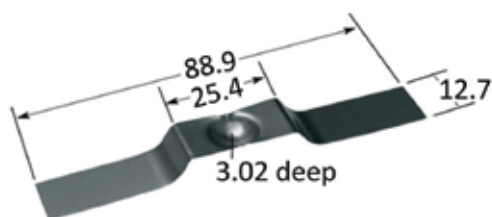

All dimensions are in mm.

P/N	VOLTS	AMPS	WATTS	TEMP.
S2B-.005Mo	1.15	119	137	1400°C
S2B-.005Ta	3.42	97	332	1600°C
S2B-.005W	3.87	140	542	1800°C
S2B-.010Mo	1.10	131	144	1400°C
S2B-.010Ta	2.33	130	303	1600°C
S2B-.010W	2.58	187	482	1800°C
S2B-.015W	2.06	245	505	1800°C



P/N	VOLTS	AMPS	WATTS	TEMP.
S3-.005Mo	0.98	64	63	1400°C
S3-.005Ta	2.04	64	131	1600°C
S3-.005W	1.95	100	195	1800°C
S3-.010Mo	77.00	103	79	1400°C
S3-.010Ta	1.44	92	132	1600°C
S3-.010W	1.47	158	232	1800°C
S3-.015W	1.96	130	255	1800°C

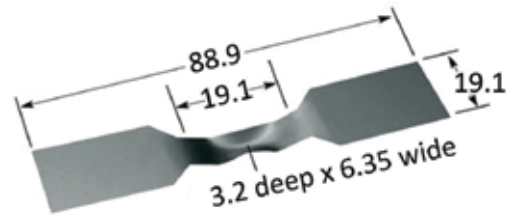

P/N	VOLTS	AMPS	WATTS	TEMP.
S4-.005Mo	1.31	63	83	1400°C
S4-.005Ta	2.62	64	168	1600°C
S4-.005W	2.76	96	265	1800°C
S4-.010Mo	0.97	93	90	1400°C
S4-.010Ta	1.83	93	170	1600°C
S4-.010W	2.03	138	280	1800°C
S4-.015W	1.51	191	288	1800°C

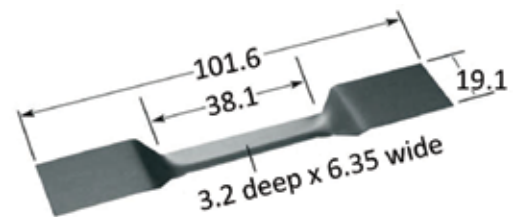

P/N	VOLTS	AMPS	WATTS	TEMP.
S5-.005Mo	1.59	133	211	1400°C
S5-.005Ta	3.29	149	490	1600°C
S5-.005W	3.18	199	633	1800°C
S5-.010Mo	1.02	208	212	1400°C
S5-.010Ta	2.09	220	460	1600°C

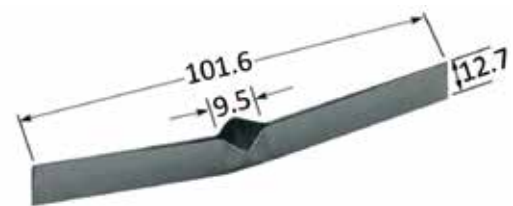

P/N	VOLTS	AMPS	WATTS	TEMP.	FEATURES
S6-.005Mo	1.46	123	180	1400°C	S6 Pan Boat
S6-.005Ta	2.77	133	368	1600°C	
S6-.005W	3.04	199	605	1800°C	
S6-.010Mo	0.99	181	179	1400°C	
S6-.010Ta	2.00	186	372	1600°C	
S6-.010W	2.14	263	563	1800°C	

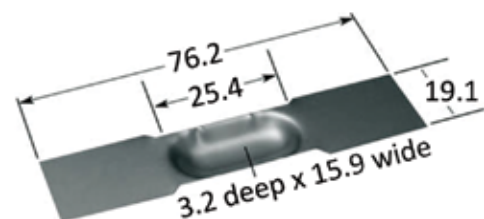

All dimensions are in mm.

P/N	VOLTS	AMPS	WATTS	TEMP.	FEATURES
S7-.005Mo	1.21	108	131	1400°C	S7 Dimple Boat
S7-.005Ta	2.48	138	342	1600°C	
S7-.005W	2.49	181	451	1800°C	
S7-.010Mo	0.96	180	173	1400°C	
S7-.010Ta	1.80	155	279	1600°C	
S7-.010W	1.92	258	495	1800°C	

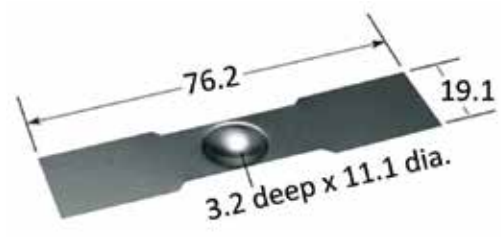

P/N	VOLTS	AMPS	WATTS	TEMP.	FEATURES
S8A-.005Mo	1.95	78	152	1400°C	S8 Isolated Hot Zone Boat (Dimple type)
S8A-.005Ta	4.44	92	408	1600°C	
S8A-.005W	4.96	136	675	1800°C	
S8A-.010Mo	1.33	112	149	1400°C	
S8A-.010Ta	2.92	129	377	1600°C	
S8A-.010W	3.11	185	575	1800°C	
S8A-.015W	2.37	234	555	1800°C	

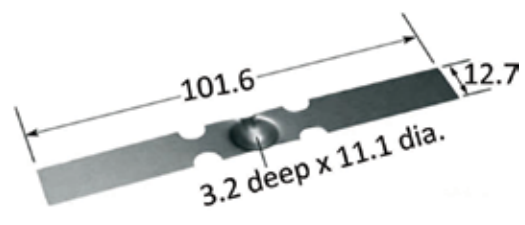

P/N	VOLTS	AMPS	WATTS	TEMP.	FEATURES
S8B-.005Mo	1.92	123	236	1400°C	S8 Isolated Hot Zone Boat (Dimple type)
S8B-.005Ta	4.44	139	617	1600°C	
S8B-.005W	3.71	204	757	1800°C	
S8B-.010Mo	1.40	170	238	1400°C	
S8B-.010Ta	2.86	190	543	1600°C	
S8B-.010W	2.85	292	832	1800°C	
S8B-.015W	2.24	374	838	1800°C	

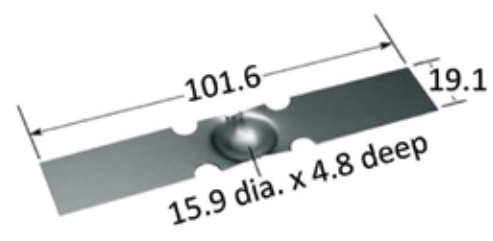

P/N	VOLTS	AMPS	WATTS	TEMP.	FEATURES
S8C-.010Mo	1.27	241	306	1400°C	S8 Isolated Hot Zone Boat (Dimple type)
S8C-.010Ta	2.97	276	820	1600°C	
S8C-.010W	2.99	387	1157	1800°C	
S8C-.015Mo	1.07	300	321	1400°C	
S8C-.015Ta	2.37	337	799	1600°C	

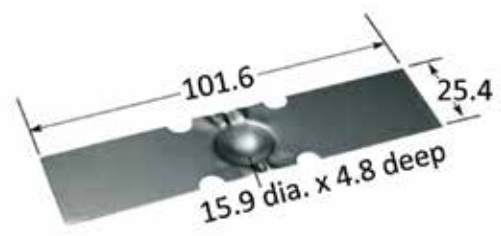

P/N	VOLTS	AMPS	WATTS	TEMP.	FEATURES
S8D-.010Mo	1.27	241	306	1400°C	S8 Isolated Hot Zone Boat (Dimple type)
S8D-.010Ta	2.97	262	778	1600°C	
S8D-.010W	2.94	378	1111	1800°C	
S8D-.015Mo	1.11	300	333	1400°C	
S8D-.015Ta	2.37	325	770	1600°C	

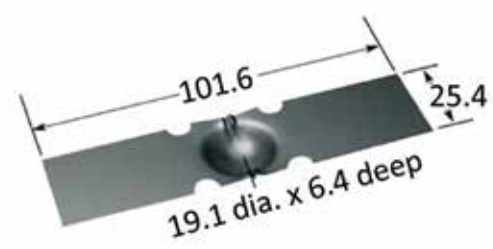

P/N	VOLTS	AMPS	WATTS	TEMP.	FEATURES
S9A-.005Mo	1.70	87	148	1400°C	S9 Dimple Boat
S9A-.005Ta	3.80	93	353	1600°C	
S9A-.005W	3.95	185	731	1800°C	
S9A-.010Mo	1.25	121	151	1400°C	
S9A-.010Ta	2.69	135	363	1600°C	
S9A-.010W	2.84	194	551	1800°C	
S9A-.015W	2.29	253	579	1800°C	

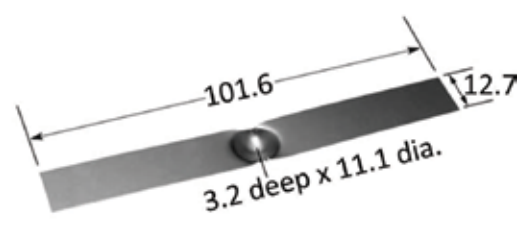

All dimensions are in mm.

P/N	VOLTS	AMPS	WATTS	TEMP.	FEATURES
S9B-.005Mo	2.01	132	265	1400°C	S9 Dimple Boat
S9B-.005Ta	4.43	146	647	1600°C	
S9B-.005W	3.50	280	980	1800°C	
S9B-.010Mo	1.30	186	242	1400°C	
S9B-.010Ta	2.98	207	617	1600°C	
S9B-.010W	3.10	325	1008	1800°C	
S9B-.015W	2.76	386	1065	1800°C	

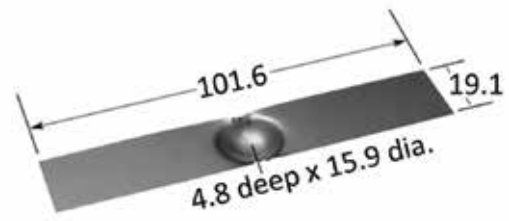

P/N	VOLTS	AMPS	WATTS	TEMP.
S9C-.010Mo	1.36	257	350	1400°C
S9C-.010Ta	3.27	281	919	1600°C
S9C-.010W	3.08	407	1254	1800°C
S9C-.015Mo	1.09	315	343	1400°C
S9C-.015Ta	2.31	333	769	1600°C

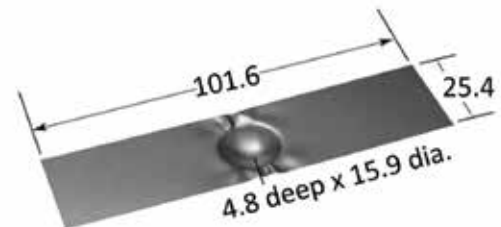

P/N	VOLTS	AMPS	WATTS	TEMP.
S9D-.010Mo	1.34	260	348	1400°C
S9D-.010Ta	2.89	262	757	1600°C
S9D-.010W	3.06	411	1258	1800°C
S9D-.015Mo	1.12	318	356	1400°C
S9D-.015Ta	2.35	333	783	1600°C
S9D-.025Ta	1.86	431	802	1600°C

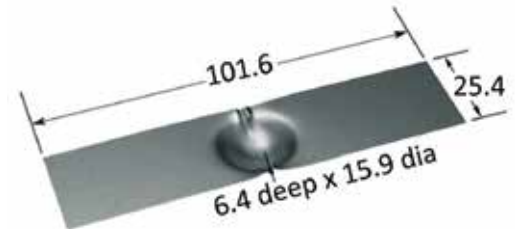

P/N	VOLTS	AMPS	WATTS	TEMP.
S9E-.010Mo	1.36	316	430	1400°C
S9E-.010Ta	2.97	340	1010	1600°C
S9E-.010W	3.21	525	1685	1800°C
S9E-.015Mo	1.12	417	467	1400°C
S9E-.015Ta	2.00	366	732	1600°C
S9E-.025Ta	1.93	539	1040	1600°C

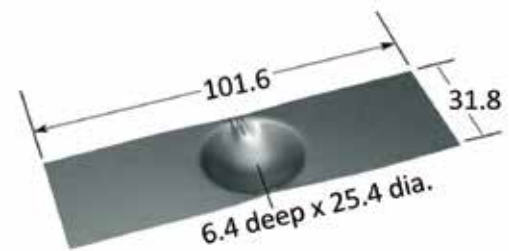

P/N	VOLTS	AMPS	WATTS	TEMP.
S9F-.010Mo	1.61	559	900	1400°C
S9F-.010Ta	3.12	601	1875	1600°C
S9F-.010W	3.31	811	2684	1800°C
S9F-.015Mo	1.44	682	982	1400°C
S9F-.015Ta	2.70	721	1947	1600°C
S9F-.025Ta	2.50	948	2370	1600°C

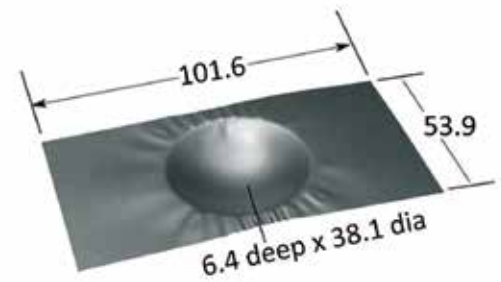

P/N	VOLTS	AMPS	WATTS	TEMP.
S10-.005Mo	2.03	170	345	1400°C
S10-.005Ta	4.26	193	822	1600°C
S10-.005W	4.4	267	1175	1800°C
S10-.010Mo	1.34	247	331	1400°C
S10-.010Ta	4.24	194	823	1600°C
S10-.010W	3.35	381	1276	1800°C

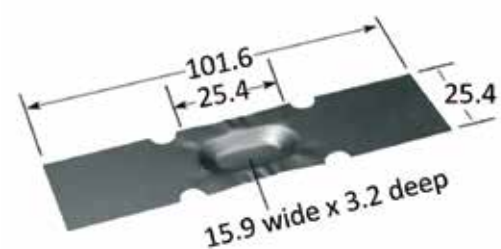

All dimensions are in mm.

P/N	VOLTS	AMPS	WATTS	TEMP.
S11-.005Mo	1.95	165	322	1400°C
S11-.005Ta	4.10	180	738	1600°C
S11-.005W	3.94	261	1028	1800°C
S11-.010Mo	1.29	236	304	1400°C
S11-.010Ta	2.86	262	749	1600°C
S11-.010W	3.03	372	1127	1800°C

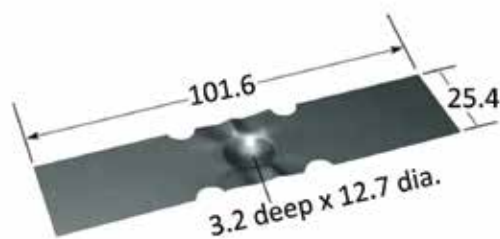

P/N	VOLTS	AMPS	WATTS	TEMP.
S12A-.005Mo	1.46	181	264	1400°C
S12A-.005Ta	2.97	197	585	1600°C
S12A-.010Mo	1.11	267	296	1400°C
S12A-.010Ta	2.22	273	606	1600°C



P/N	VOLTS	AMPS	WATTS	TEMP.
S12B-.005Mo	0.96	196	188	1400°C
S12B-.005Ta	1.82	203	369	1600°C
S12B-.010Mo	0.78	320	250	1400°C
S12B-.010Ta	1.48	298	441	1600°C



P/N	VOLTS	AMPS	WATTS	TEMP.
S13-.005Mo	1.32	106	140	1400°C
S13-.005Ta	2.87	110	316	1600°C
S13-.005W	3.04	149	543	1800°C
S13-.010Mo	0.97	156	151	1400°C
S13-.010Ta	1.92	158	303	1600°C



P/N	VOLTS	AMPS	WATTS	TEMP.
S14-.005Mo	1.71	170	291	1400°C
S14-.005Ta	3.92	179	702	1600°C
S14-.005W	4.21	283	1191	1800°C
S14-.010Mo	1.19	240	286	1400°C
S14-.010Ta	2.53	259	655	1600°C
S14-.010W	2.52	402	1013	1800°C
S14-.015W	2.40	459	1102	1800°C



P/N	VOLTS	AMPS	WATTS	TEMP.
S15-.005Mo	1.76	86	151	1400°C
S15-.005Ta	3.80	90	342	1600°C
S15-.005W	4.08	144	588	1800°C
S15-.010Mo	1.23	129	159	1400°C
S15-.010Ta	2.86	133	380	1600°C
S15-.010W	3.04	200	608	1800°C
S15-.015W	2.23	249	555	1800°C



All dimensions are in mm.

P/N	VOLTS	AMPS	WATTS	TEMP.
S16-.005Mo	0.87	73	64	1400°C
S16-.005Ta	1.49	65	97	1600°C
S16-.005W	1.58	110	174	1800°C
S16-.010Mo	0.72	131	94	1400°C
S16-.010Ta	1.17	115	135	1600°C
S16-.010W	1.10	143	159	1800°C

P/N	VOLTS	AMPS	WATTS	TEMP.
S17A-.005Ta	2.15	158	340	1600°C
S17A-.010Ta	1.40	183	256	1600°C

P/N	VOLTS	AMPS	WATTS	TEMP.
S17B-.005Ta	1.93	125	241	1600°C
S17B-.010Ta	1.43	187	267	1600°C

P/N	VOLTS	AMPS	WATTS	TEMP.
S18-BN	0	0	0	N/A
S18-C	11.35	317	3598	2000°C
S18-Mo	0.78	983	767	1400°C
S18-Ta	0	0	0	N/A
Cavity 50.8 mm long 9.5 mm wide				

P/N	VOLTS	AMPS	WATTS	TEMP.
S19A-Ta	1.71	130	222	1600°C

Electrical welding for sublimation only.
Not leak proof.

P/N	VOLTS	AMPS	WATTS	TEMP.
S19B-Ta	1.83	134	245	1600°C

Electrical welding for sublimation only.
Not leak proof.

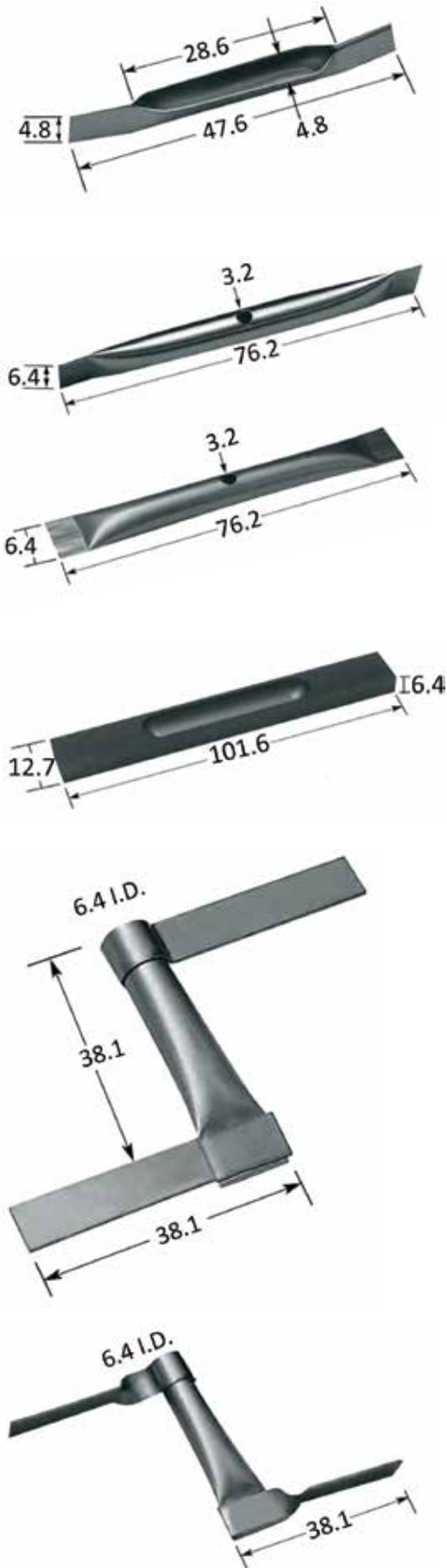

All dimensions are in mm.

P/N	VOLTS	AMPS	WATTS	TEMP.
S19C-Ta	2.64	132	348	1600°C

Electrical welding for sublimation only.
Not leak proof.



P/N	VOLTS	AMPS	WATTS	TEMP.
S20A-.005Mo	1.84	81	149	1400°C
S20A-.005Ta	3.40	94	320	1600°C
S20A-.005W	3.95	140	553	1800°C
S20A-.010Mo	1.27	129	164	1400°C
S20A-.010Ta	2.61	129	337	1600°C
S20A-.010W	2.90	196	568	1800°C
S20A-.015W	2.10	250	525	1800°C



P/N	VOLTS	AMPS	WATTS	TEMP.
S21-.005Mo	2.11	123	260	1400°C
S21-.005Ta	4.50	138	621	1600°C
S21-.005W	3.26	144	469	1800°C
S21-.010Mo	1.47	184	270	1400°C
S21-.010Ta	2.87	198	568	1600°C
S21-.010W	3.28	300	984	1800°C

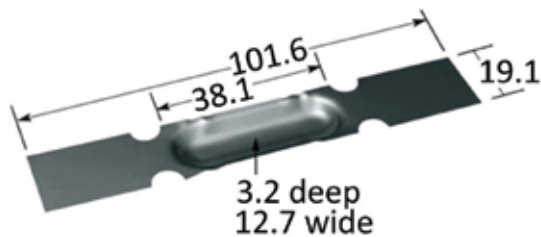

P/N	VOLTS	AMPS	WATTS	TEMP.
S22-.005Mo	1.54	122	188	1400°C
S22-.005Ta	2.94	150	441	1600°C
S22-.005W	3.32	198	657	1800°C
S22-.010Mo	1.09	190	207	1400°C
S22-.010Ta	2.28	209	477	1600°C
S22-.010W	2.55	283	722	1800°C



P/N	VOLTS	AMPS	WATTS	TEMP.
S23-.010Mo	0.88	301	265	1400°C
S23-.010Ta	1.68	295	496	1600°C
S23-.010W	1.50	375	562	1800°C

2 pcs top and bottom



P/N	VOLTS	AMPS	WATTS	TEMP.
S24-.005Mo	1.24	202	250	1400°C
S24-.005Ta	2.28	190	433	1600°C
S24-.005W	2.21	256	566	1800°C
S24-.010Mo	0.83	297	247	1400°C
S24-.010Ta	1.77	329	582	1600°C
S24-.010W	1.70	386	656	1800°C

2 pcs top and bottom



All dimensions are in mm.

P/N	VOLTS	AMPS	WATTS	TEMP.
S25-.010Mo	1.14	300	342	1400°C
S25-.010Ta	2.16	272	588	1600°C
S25-.010W	2.30	375	862	1800°C
2 pcs top and bottom				



P/N	VOLTS	AMPS	WATTS	TEMP.
S26-.010Mo	1.10	278	306	1400°C
S26-.010Ta	2.40	293	703	1600°C
S26-.010W	2.14	383	820	1800°C
2 pcs top and bottom				



P/N	VOLTS	AMPS	WATTS	TEMP.
S27-.005Mo	0.94	94	88	1600°C
S27-.005Ta	2.09	99	207	1600°C
S27-.005W	2.22	134	297	1800°C
S27-.010Mo	0.75	148	111	1600°C
S27-.010Ta	1.48	137	203	1600°C
S27-.010W	1.57	185	290	1800°C



P/N	VOLTS	AMPS	WATTS	TEMP.	FEATURES
S28-.005Mo	1.92	86	165	1400°C	Dimple Boat
S28-.005Ta	3.74	92	344	1600°C	
S28-.005W	3.81	131	499	1800°C	
S28-.010Mo	1.27	127	161	1400°C	
S28-.010Ta	2.69	132	355	1600°C	
S28-.010W	2.93	187	548	1800°C	

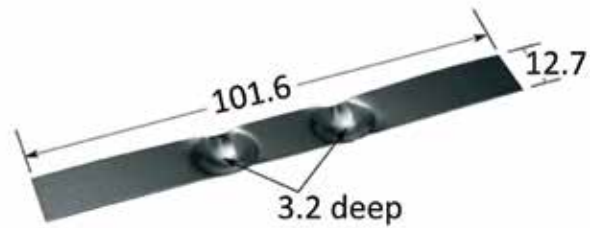

P/N	VOLTS	AMPS	WATTS	TEMP.
S29-.005Mo	2.10	198	416	1400°C
S29-.005Ta	4.50	221	994	1600°C
S29-.005W	4.29	316	1356	1800°C
S29-.010Mo	1.43	281	402	1400°C
S29-.010Ta	3.36	322	1082	1600°C
S29-.010W	3.30	451	1488	1800°C
S29-.015Ta	2.56	406	1039	1600°C

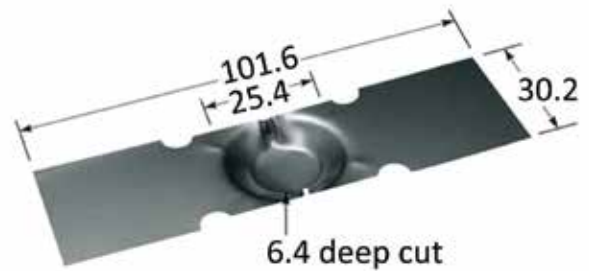

P/N	VOLTS	AMPS	WATTS	TEMP.
S30A-.005Ta	2.60	400	1040	1800°C
S30A-.005W	1.50	444	666	1800°C
S30A-.010Ta	1.44	296	427	1600°C
S30A-.010W	1.50	444	666	1800°C



All dimensions are in mm.

P/N	VOLTS	AMPS	WATTS	TEMP.
S31A-005Mo	0.66	75	50	1400°C
S31A-005Ta	1.24	83	103	1600°C
S31A-005W	2.00	166	332	1800°C
S31A-010Mo	0.53	129	68	1400°C
S31A-010Ta	0.98	119	117	1600°C
S31A-010W	1.63	214	349	1800°C
S31A-015Mo	0.55	173	95	1400°C
S31A-015Ta	1.07	155	166	1600°C
S31A-015W	1.40	261	365	1800°C

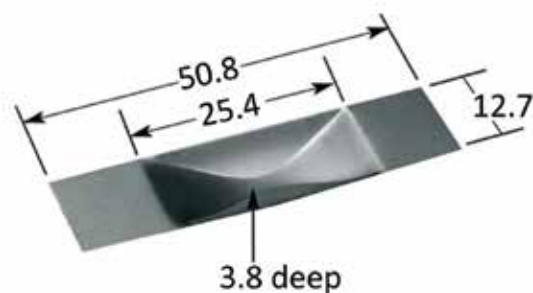

P/N	VOLTS	AMPS	WATTS	TEMP.
S32-010W	2.38	738	1756	2000°C

Accommodates C1 and C9 crucibles



P/N	VOLTS	AMPS	WATTS	TEMP.
S33-005Mo	1.46	94	137	1400°C
S33-005Ta	3.27	94	307	1600°C
S33-005W	3.26	144	469	1800°C

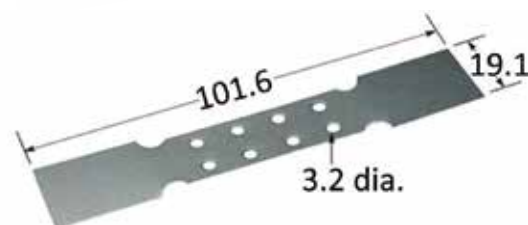

P/N	VOLTS	AMPS	WATTS	TEMP.
S34-005Mo	1.70	123	209	1400°C
S34-005Ta	3.82	135	516	1600°C
S34-005W	3.46	181	626	1800°C
S34-010Mo	1.25	169	211	1400°C
S34-010Ta	2.75	177	487	1600°C
S34-010W	2.66	259	689	1800°C

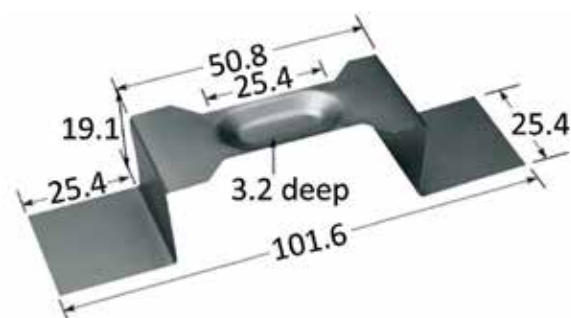

P/N	VOLTS	AMPS	WATTS	TEMP.
S35-005Mo	1.44	87	125	1400°C
S35-005Ta	3.10	91	282	1600°C
S35-005W	3.37	140	472	1800°C
S35-010Mo	1.05	124	130	1400°C
S35-010Ta	2.13	134	285	1600°C
S35-010W	2.26	207	468	1800°C



P/N	VOLTS	AMPS	WATTS	TEMP.
S36-010Mo	1.33	251	334	1400°C
S36-010Ta	2.98	250	745	1600°C
S36-010W	3.01	391	1177	1800°C
S36-015Ta	2.27	322	731	1600°C



All dimensions are in mm.

P/N	VOLTS	AMPS	WATTS	TEMP.
S37-.005Mo	1.84	201	370	1400°C
S37-.005Ta	4.26	222	946	1600°C
S37-.010Mo	1.30	289	376	1400°C
S37-.010Ta	3.21	319	1024	1600°C



P/N	VOLTS	AMPS	WATTS	TEMP.
S38-.005Mo	1.77	114	202	1400°C
S38-.005Ta	4.01	114	457	1600°C
S38-.005W	3.98	169	673	1800°C
S38-.010Mo	1.26	164	207	1400°C
S38-.010Ta	2.70	197	532	1600°C
S38-.010W	2.77	254	704	1800°C



P/N	VOLTS	AMPS	WATTS	TEMP.
S39-.005Mo	1.32	100	132	1400°C
S39-.005Ta	2.72	106	288	1600°C
S39-.010Mo	0.90	157.95	141.68	1400°C
S39-.010Ta	1.95	165	322	1600°C

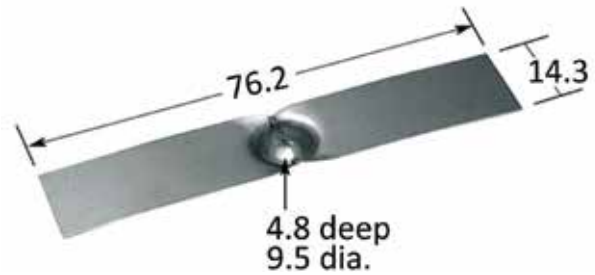

P/N	VOLTS	AMPS	WATTS	TEMP.
S40-.005Mo	1.39	105	146	1400°C
S40-.005Ta	2.61	120	313	1600°C
S40-.005W	2.71	155	420	1800°C
S40-.010Mo	0.92	149.42	138.16	1400°C
S40-.010Ta	2.01	156	314	1600°C



P/N	VOLTS	AMPS	WATTS	TEMP.
S42-.005W	3.67	188	690	1800°C
S42-.010Mo	1.58	249	393	1400°C
S42-.010Ta	3.35	281	941	1600°C
S42-.010W	2.82	269	759	1800°C
S42-.015Mo	1.27	310	394	1400°C
S42-.015Ta	2.61	328	856	1600°C
S42-.015W	2.57	508	1306	1800°C

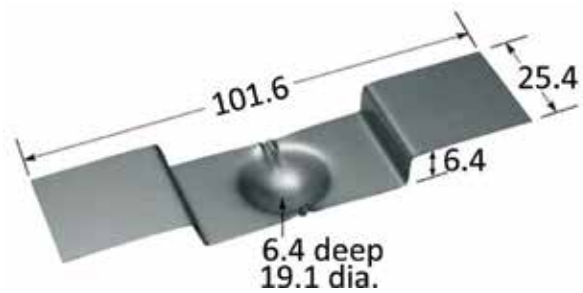

P/N	VOLTS	AMPS	WATTS	TEMP.
S43-.005W	4.59	372	1707	1800°C
S43-.010Mo	1.52	317	482	1400°C
S43-.010Ta	3.48	338	1176	1600°C
S43-.010W	3.53	531	1874	1800°C
S43-.015Mo	1.22	389	475	1400°C
S43-.015Ta	2.83	416	1177	1600°C
S43-.015W	2.91	654	1903	1800°C

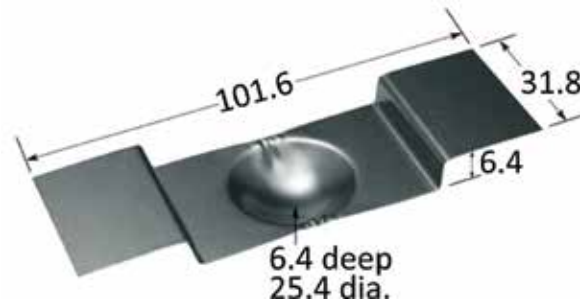

All dimensions are in mm.

P/N	VOLTS	AMPS	WATTS	TEMP.
S44-.005Mo	2.05	117	240	1400°C
S44-.005Ta	3.80	115	437	1600°C
S44-.005W	3.73	182	679	1800°C
S44-.010Mo	1.33	170	226	1400°C
S44-.010Ta	2.90	178	516	1600°C
S44-.010W	2.87	260	746	1800°C
S44-.015Mo	1.06	207	219	1400°C
S44-.015Ta	2.38	220	524	1600°C
S44-.015W	2.31	327	755	1800°C



P/N	VOLTS	AMPS	WATTS	TEMP.
S45-.005Mo	2.11	176	371	1400°C
S45-.005Ta	4.60	189	869	1600°C
S45-.005W	4.41	276	1217	1800°C
S45-.010Mo	1.45	249	361	1400°C
S45-.010Ta	3.16	257	812	1600°C
S45-.010W	3.39	394	1336	1800°C
S45-.015Mo	1.29	310	400	1400°C
S45-.015Ta	2.55	320	816	1600°C
S45-.015W	2.72	503	1368	1800°C



P/N	VOLTS	AMPS	WATTS	TEMP.
S46-.005Mo	2.10	207	435	1400°C
S46-.005Ta	4.87	221	1076	1600°C
S46-.005W	4.34	340	1476	1800°C
S46-.010Mo	1.49	293	437	1400°C
S46-.010Ta	3.20	306	979	1600°C
S46-.010W	3.34	485	1620	1800°C



P/N	VOLTS	AMPS	WATTS	TEMP.
S47-.010Mo	1.18	142	168	1400°C
S47-.010Ta	2.59	144	373	1600°C
S47-.010W	2.87	212	608	1800°C
S47-.015Mo	1.00	179	179	1400°C
S47-.015Ta	2.06	190	391	1600°C
S47-.015W	2.18	287	626	1800°C
S47-.020Ta	1.91	210	401	1600°C
S47-.020W	2.00	333	666	1800°C

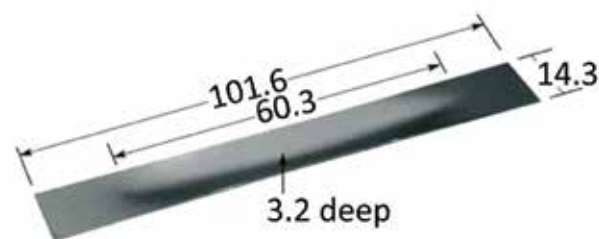

P/N	VOLTS	AMPS	WATTS	TEMP.
S48-.005W	3.67	81	297	1800°C
S48-.010Mo	1.24	75	93	1400°C
S48-.010Ta	2.41	81	195	1600°C
S48-.010W	2.82	115	324	1800°C

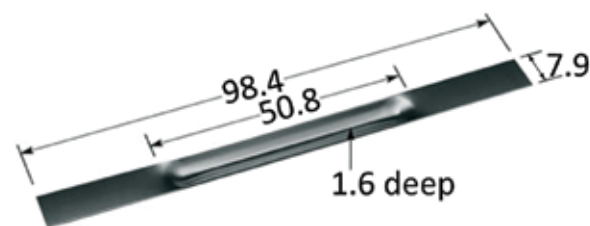

All dimensions are in mm.

P/N	VOLTS	AMPS	WATTS	TEMP.
S49-.010Mo	1.58	249	393	1400°C
S49-.010Ta	3.35	281	941	1600°C
S49-.010W	2.82	269	759	1800°C
S49-.015Mo	1.27	310	394	1400°C
S49-.015Ta	2.61	328	856	1600°C
S49-.015W	2.57	508	1306	1800°C
S49-.020Ta	2.35	401	942	1600°C
S49-.020W	1.97	726	1430	1800°C

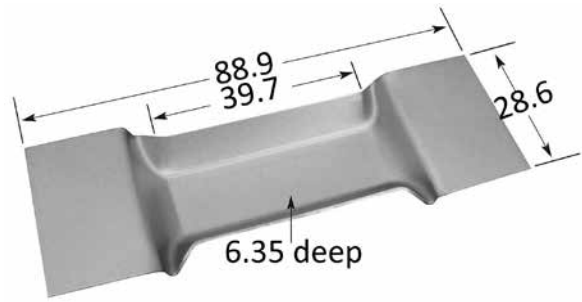

P/N	VOLTS	AMPS	WATTS	TEMP.
S50-.010Mo	1.36	316	430	1400°C
S50-.010Ta	2.97	340	1010	1600°C
S50-.010W	1.36	316	430	1800°C
S50-.015Mo	1.12	417	467	1400°C
S50-.015Ta	2	366	732	1600°C
S50-.015W	1.15	386	442	1800°C
S50-.020Ta	2.08	485	1009	1600°C
S50-.020W	0.95	451	428	1800°C

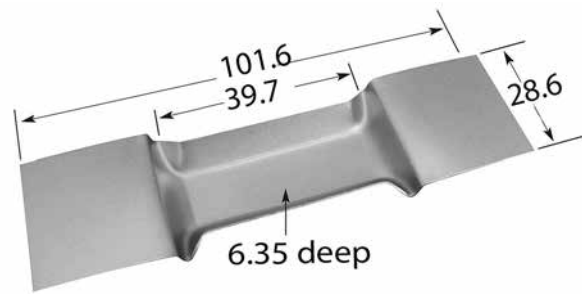

P/N	VOLTS	AMPS	WATTS	TEMP.
S51-.010Mo	1.2	280	336	1400°C
S51-.010Ta	2.42	295	714	1600°C
S51-.010W	2.2	388	854	1800°C

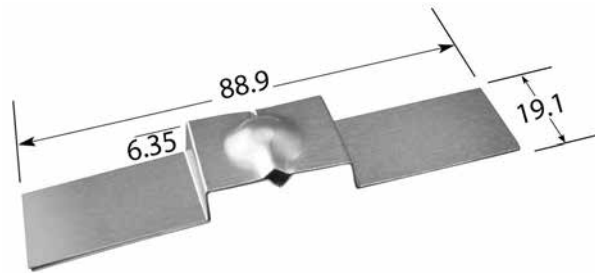

P/N	VOLTS	AMPS	WATTS	TEMP.
S52-.010Mo	1.3	198	257	1400°C
S52-.010Ta	2.9	218	632	1600°C
S52-.010W	3.1	330	1023	1800°C
S52-.020W	2.6	354	920	1800°C
S52-.025W	2.1	457	960	1800°C

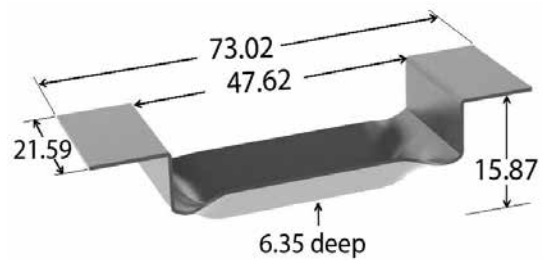

Mo: Molybdenum, Ta: Tantalum, W: Tungsten.

All dimensions are in mm.

Folded Boats

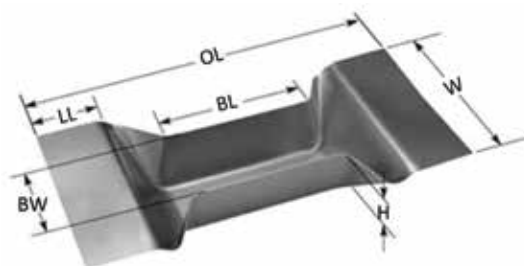

P/N	BL	BW	H	OL	W	LL	VOL	MATERIAL
FB1	47.75	19.05	18.55	114.3	53.85	19.05	17cc	Available in thickness 0.005", 0.010" & 0.015" Mo & Ta Tungsten on request
FB2	47.75	33.02	11.94	110.24	53.85	19.05	19cc	
FB3	95.25	25.4	12.7	156.46	53.85	20.83	31cc	
FB4	95.25	19.05	19.05	156.46	53.85	19.05	35cc	

Available on request: Al₂O₃ coated inside or Al₂O₃ barrier type

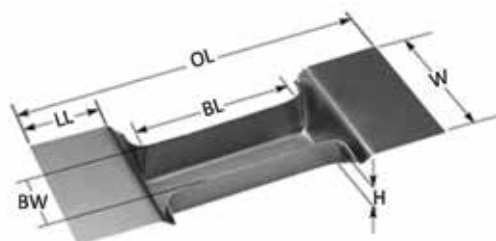

P/N	BL	BW	H	OL	W	LL	VOL	MATERIAL
FB10	16.77	11.43	10.92	36.07	31.75	9.66	2cc	Available in thickness 0.005", 0.010" & 0.015" Mo & Ta Tungsten on request
FB11	31.75	9.66	7.87	65.03	25.4	14.23	3cc	
FB12	39.63	12.7	7.87	74.68	28.7	17.53	4cc	

Available on request: Al₂O₃ coated inside or Al₂O₃ barrier type

All dimensions are in mm.

P/N	VOLTS	AMPS	WATTS	TEMP.
FB1-.005Mo	1.65	293	483	1400°C
FB1-.005Ta	3.78	339	1281	1600°C
FB1-.010Mo	1.21	413	500	1400°C
FB1-.010Ta	2.93	162	1354	1600°C
FB1-.015Mo	1.38	634	875	1400°C
FB1-.015Ta	2.57	641	1647	1600°C
FB2-.005Mo	1.90	320	608	1400°C
FB2-.005Ta	3.88	348	1350	1600°C
FB2-.010Mo	1.38	448	618	1400°C
FB2-.010Ta	2.77	491	1360	1600°C
FB2-.015Mo	1.16	547	635	1400°C
FB2-.015Ta	2.56	657	1682	1600°C
FB3-.005Mo	2.23	303	676	1400°C
FB3-.005Ta	4.60	301	1385	1600°C
FB3-.010Mo	1.60	431	690	1400°C
FB3-.010Ta	3.89	521	2027	1600°C
FB3-.015Mo	1.38	536	740	1400°C
FB3-.015Ta	3.73	736	2745	1600°C
FB4-.005Mo	2.18	300	654	1400°C
FB4-.005Ta	4.14	277	1147	1600°C
FB4-.010Mo	1.60	413	661	1400°C
FB4-.010Ta	3.64	495	1802	1600°C
FB4-.015Mo	1.72	663	1140	1400°C
FB4-.015Ta	3.15	646	2035	1600°C

P/N	VOLTS	AMPS	WATTS	TEMP.
FB10-.005Mo	0.75	166	125	1400°C
FB10-.005Ta	1.56	159	248	1600°C
FB10-.010Mo	0.66	265	175	1400°C
FB10-.010Ta	1.12	242	271	1600°C
FB10-.015Mo	0.68	351	237	1400°C
FB10-.015Ta	1.12	341	382	1600°C
FB11-.005Mo	1.11	118	131	1400°C
FB11-.005Ta	2.12	137	290	1600°C
FB11-.010Mo	0.76	186	141	1400°C
FB11-.010Ta	1.69	207	350	1600°C
FB11-.015Mo	0.71	243	173	1400°C
FB11-.015Ta	1.45	253	367	1600°C
FB12-.005Mo	1.20	143	172	1400°C
FB12-.005Ta	2.00	141	282	1600°C
FB12-.010Mo	0.88	211	185	1400°C
FB12-.010Ta	1.63	200	326	1600°C
FB12-.015Mo	0.83	272	227	1400°C
FB12-.015Ta	1.49	257	383	1600°C

Mo: Molybdenum, Ta: Tantalum.

All dimensions are in mm.

Alumina Coated Evaporation Sources

Alumina coated evaporation sources have been developed to replace alumina crucibles for some specific applications. The advantages of this type of evaporation source are good heat transfer and the inertness of alumina with most metals. Also, the evaporant does not wet the alumina resulting in no resistant change of the boat when the evaporant melts. Due to the non wetting characteristics of alumina, the evaporant forms a sphere when melted resulting in a point source. This type of evaporation source will give long life compared to the non protected sources. Coated sources will require from thirty to fifty percent more power to effect an evaporation do to the difference in heat conduction. The alumina is semi-conductor grade and is applied to the boat or basket by a plasma spray technique. Temperatures over 1850°C should be avoided, and when an evaporation is effected the power should be reduced slightly to avoid over heating.

P/N	VOLTS	AMPS	WATTS	TEMP.
S1-A0-Mo	0.95	105	100	1200°C
S1-A0-W	1.00	106	106	1200°C

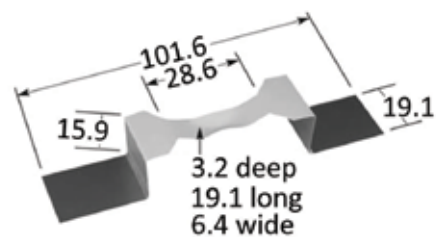

P/N	VOLTS	AMPS	WATTS	TEMP.
S2B-A0-Mo	1.12	141	158	1200°C
S2B-A0-W	1.13	141	159	1200°C

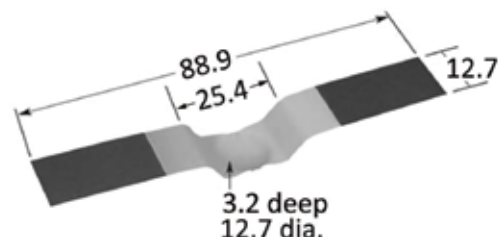

All dimensions are in mm.

P/N	VOLTS	AMPS	WATTS	TEMP.
S3-AO-Mo	0.79	114	90	1200°C
S3-AO-W	0.83	117	97	1200°C

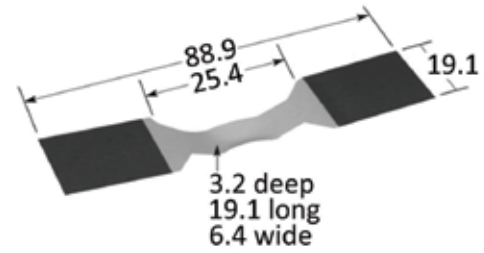

P/N	VOLTS	AMPS	WATTS	TEMP.
S8C-AO-Mo	1.31	253	331	1200°C
S8C-AO-W	1.27	257	326	1200°C

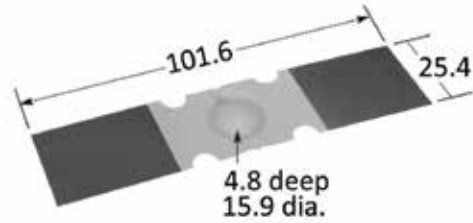

P/N	VOLTS	AMPS	WATTS	TEMP.
S9A-AO-Mo	1.21	130	157	1200°C
S9A-AO-W	1.17	125	146	1200°C

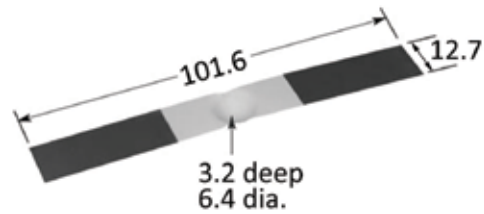

P/N	VOLTS	AMPS	WATTS	TEMP.
S9B-AO-Mo	1.34	201	269	1200°C
S9B-AO-W	1.29	190	245	1200°C

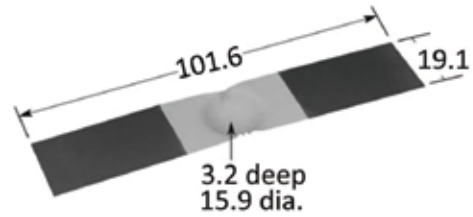

P/N	VOLTS	AMPS	WATTS	TEMP.
S9C-AO-Mo	1.14	248	283	1200°C
S9C-AO-W	1.35	268	362	1200°C

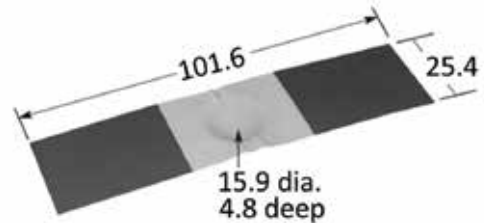

P/N	VOLTS	AMPS	WATTS	TEMP.
S9F-AO-Mo	1.50	586	879	1200°C
S9F-AO-W	1.40	635	889	1200°C

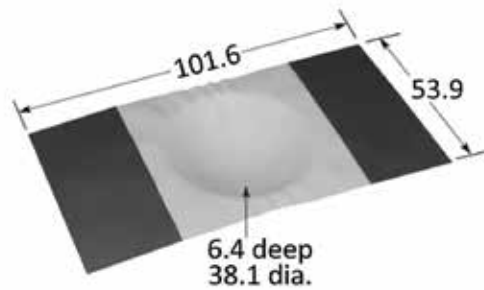

P/N	VOLTS	AMPS	WATTS	TEMP.
S21-AO-Mo	1.34	207	277	1200°C
S21-AO-W	1.47	204	300	1200°C

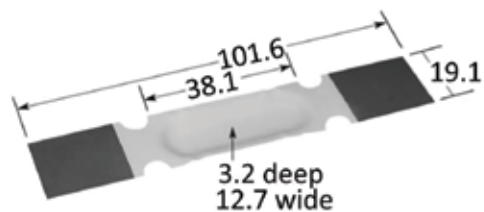

All dimensions are in mm.

P/N	VOLTS	AMPS	WATTS	TEMP.
S29-A0-Mo	1.41	220	310	1200°C
S29-A0-W	1.34	294	394	1200°C



P/N	VOLTS	AMPS	WATTS	TEMP.
S35A-A0-Mo	1.05	144	151	1200°C
S35A-A0-W	0.95	136	129	1200°C

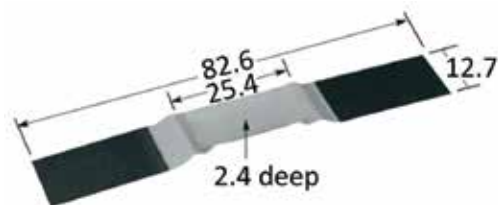

P/N	VOLTS	AMPS	WATTS	TEMP.
S35B-A0-Mo	0.90	137	123	1200°C
S35B-A0-W	0.89	130	116	1200°C
Evaporation area: 6.35 mm x 19.05 mm				

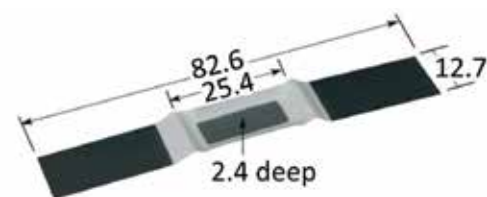

P/N	VOLTS	AMPS	WATTS	TEMP.
S36-A0-Mo	1.34	289	387	1200°C
S36-A0-W	1.25	268	335	1200°C



P/N	VOLTS	AMPS	WATTS	TEMP.
S37-A0-Mo	1.23	326	401	1200°C

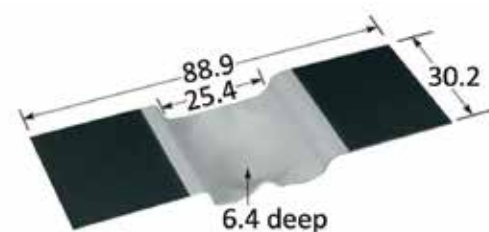

P/N	VOLTS	AMPS	WATTS	TEMP.
S38A-A0-Mo	1.22	181	221	1200°C
S38A-A0-W	1.20	169	203	1200°C

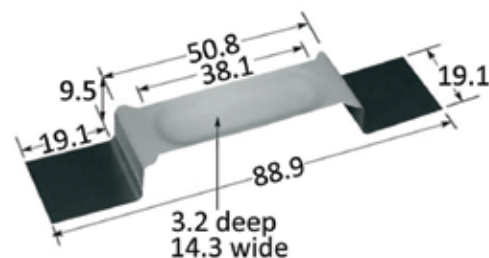

P/N	VOLTS	AMPS	WATTS	TEMP.
S38B-A0-Mo	1.04	167	174	1200°C
S38B-A0-W	1.04	156	162	1200°C

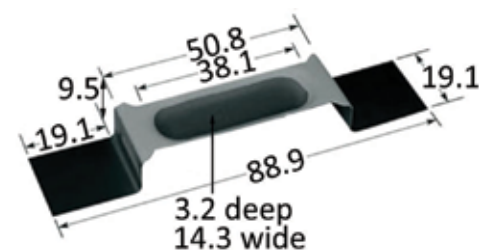

All dimensions are in mm.

P/N	VOLTS	AMPS	WATTS	TEMP.
S42B-AO-Mo	1.35	262	354	1200°C
S42B-AO-W	1.41	245	345	1200°C
Evaporation area: 19.05 mm x 6.35 mm				

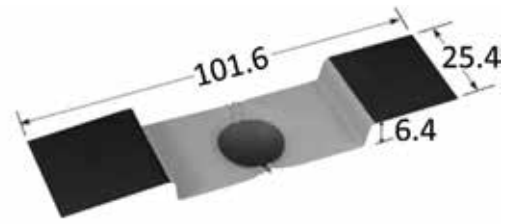

P/N	VOLTS	AMPS	WATTS	TEMP.
S45B-AO-Mo	1.27	264	335	1200°C
S45B-AO-W	1.43	264	378	1200°C
Evaporation area: 15.88 mm x 19.05 mm				

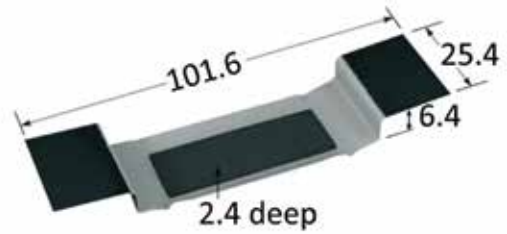

P/N	VOLTS	AMPS	WATTS	TEMP.
S51-AO-MO	0.94	287	270	1200°C
Al ₂ O ₃ coating Mo boat				



P/N	VOLTS	AMPS	WATTS	TEMP.
SB3-AO-TA	1.54	295	454	1200°C
Al ₂ O ₃ coating 0.010" Ta boat				

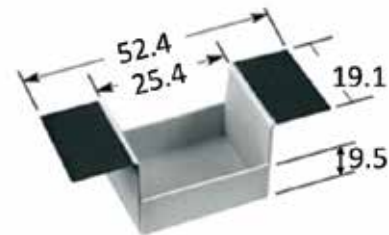

P/N	VOLTS	AMPS	WATTS	TEMP.
SB3A-AO-Ta	1.49	345	514	1200°C
Al ₂ O ₃ coating 0.005" Ta boat Both under and top surfaces coated				

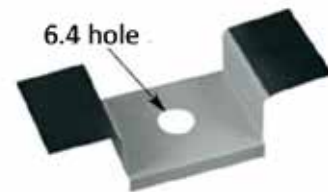

P/N	VOLTS	AMPS	WATTS	TEMP.
SB5-AO-Ta	2.20	314	691	1200°C
Al ₂ O ₃ coating 0.010" Ta boat				



P/N	VOLTS	AMPS	WATTS	TEMP.
SB5A-AO	1.63	334	544	1200°C
Al ₂ O ₃ coating 0.005" Ta boat Both under and top surfaces coated				



All dimensions are in mm.

P/N	VOLTS	AMPS	WATTS	TEMP.
ME3-A0-Mo	0.86	151	130	1200°C

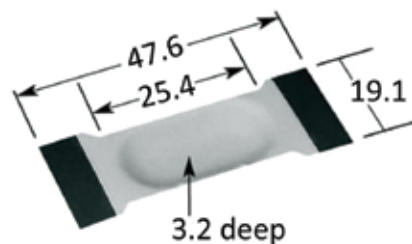

P/N	VOLTS	AMPS	WATTS	TEMP.
ME4-A0-Mo	0.83	116	96	1200°C
Al ₂ O ₃ coating 0.005" Mo boat				

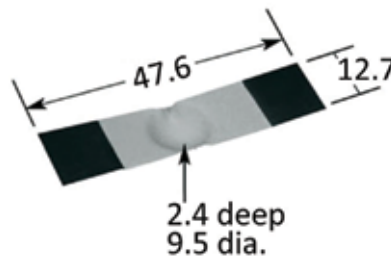

P/N	VOLTS	AMPS	WATTS	TEMP.
ME6B-A0-Mo	0.84	106	89	1200°C
Al ₂ O ₃ coating 0.005" Mo boat				

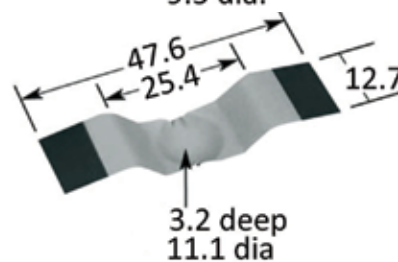

P/N	VOLTS	AMPS	WATTS	TEMP.
ME9-A0-Mo	0.80	83	66	1200°C
Al ₂ O ₃ coating 0.005" Mo boat				

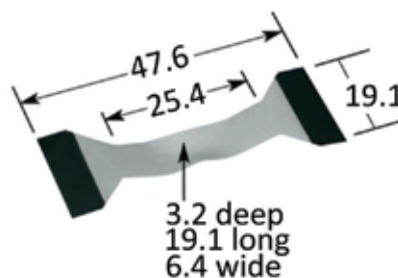

P/N	VOLTS	AMPS	WATTS	TEMP.
ME22-A0-Ta	1.30	259	337	1200°C
Al ₂ O ₃ coating 0.005" Mo boat				

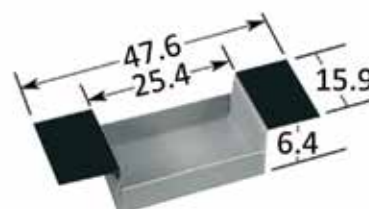

P/N	VOLTS	AMPS	WATTS	TEMP.
ME22A-A0	1.09	293	319	1200°C
Al ₂ O ₃ coating 0.005" Ta boat Both under and top surfaces coated				

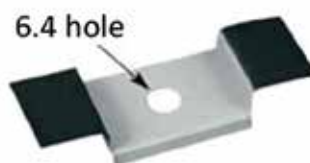

P/N	VOLTS	AMPS	WATTS	TEMP.
ME25-A0-MO	0.94	274	258	1200°C
Al ₂ O ₃ coating 0.005" Mo boat				

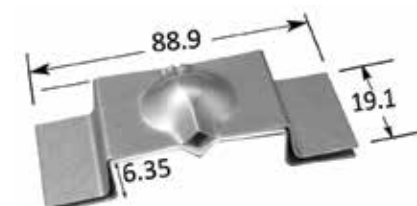

All dimensions are in mm.

P/N	BL	W	H	OL	P	VOL.
SB-7A-AO-.010Mo	44.45	25.4	19.05	88.9	1.53 60 holes 4 x 15 rows	21cc
SB-7A-AO-.010Ta						
SB-7C-AO-.005Mo						
SB-7C-AO-.005Ta	44.45	38.1	25.4	88.9	1.53 70 holes 5 x 15 rows	43cc
SB-8A-AO-.010Mo						
SB-8A-AO-.010Ta						
SB-8C-AO-.005Mo	76.2	35.05	19.05	120.65	1.53 115 holes 5 x 23 rows	50cc
SB-8C-AO-.005Ta						
SB-9A-AO-.010Mo						
SB-9A-AO-.010Ta	69.85	50.8	31.75	101.6	3.05 65 holes 5 x 13 rows	112cc
SB-9C-AO-.005Mo						
SB-9C-AO-.005Ta						
SB-10A-AO-.010Mo						
SB-10A-AO-.010Ta						
SB-10C-AO-.005Mo						
SB-10C-AO-.005Ta						

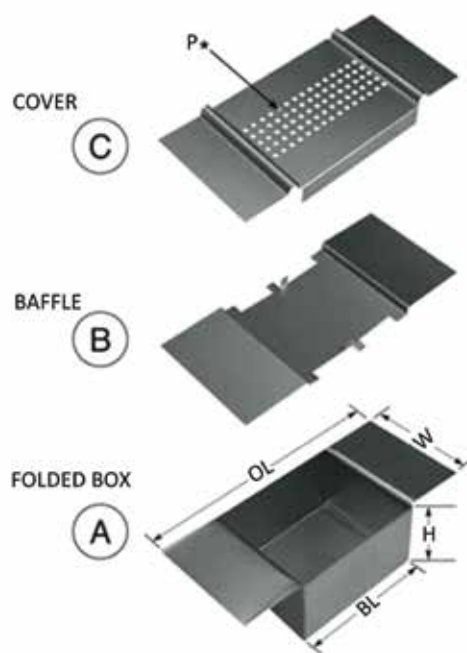

P* single hole sizes available on request.

STANDARD MATERIALS		
	Standard	Al ₂ O ₃ coated
C	0.005" / Mo or Ta	0.005" or 0.010" / Mo or Ta
B	0.005" / Mo or Ta	Normally not used
A	0.005" or 0.010" / Mo or Ta	0.010" / Mo or Ta

ORDER INFORMATION

EXAMPLE: SB-10-C-.010 Ta-AO, MODIFIED, 3/4 DIA. HOLE IN CENTER

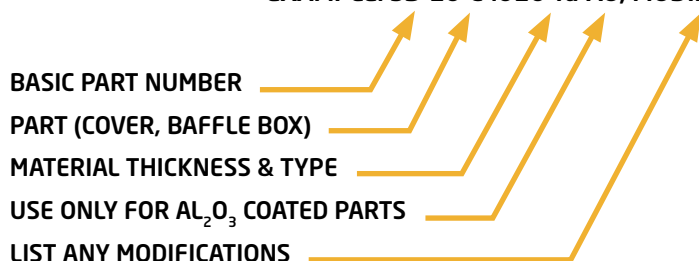

Mo: Molybdenum, W: Tungsten, Ta: Tantalum.

All dimensions are in mm.

Special Tantalum Boats

P/N	VOLTS	AMPS	WATTS	TEMP.
SB-1	4.14	707	2927	1600°C
0.010" Ta baffled				



P/N	VOLTS	AMPS	WATTS	TEMP.
SB-1A	3.20	749	2397	1600°C
0.005" Ta baffled				



P/N	VOLTS	AMPS	WATTS	TEMP.
SB-1B	3.2	749	2397	1600°C
0.005" Ta baffled				

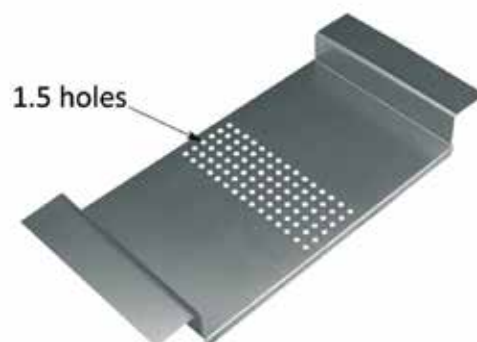

All dimensions are in mm.

P/N	VOLTS	AMPS	WATTS	TEMP.
SB-2	3.70	388	1436	1600°C
0.010" Ta				

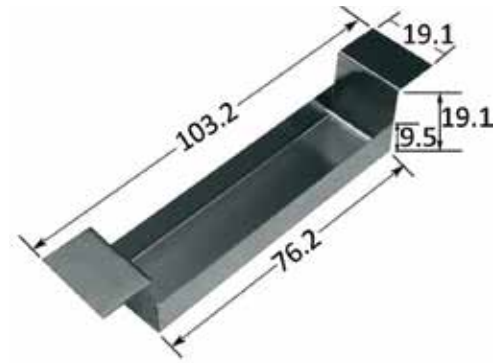

P/N	VOLTS	AMPS	WATTS	TEMP.
SB-2A	2.91	398	1158	1600°C
0.005" Ta				



P/N	VOLTS	AMPS	WATTS	TEMP.
SB-2B	2.91	398	1158	1600°C
0.005" Ta				

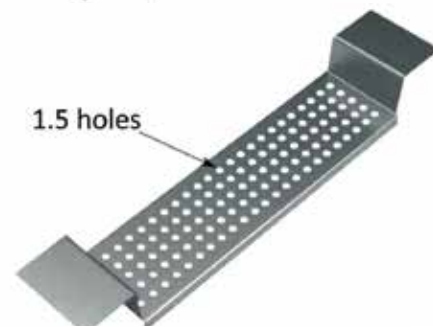

P/N	VOLTS	AMPS	WATTS	TEMP.
SB-3	2.08	366	761	1600°C
0.010" Ta				

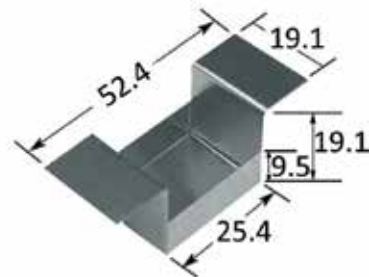

P/N	VOLTS	AMPS	WATTS	TEMP.
SB-3A	1.63	380	619	1600°C
0.005" Ta				

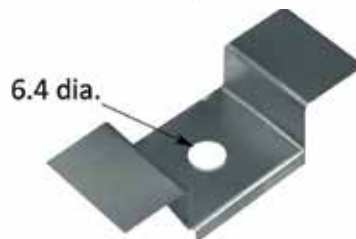

P/N	VOLTS	AMPS	WATTS	TEMP.
SB-3B	1.63	380	619	1600°C
0.005" Ta				

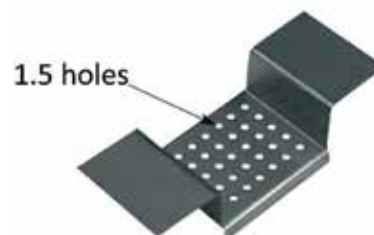

All dimensions are in mm.

P/N	VOLTS	AMPS	WATTS	TEMP.
SB-4	3.57	438	1564	1600°C
0.010 Ta				

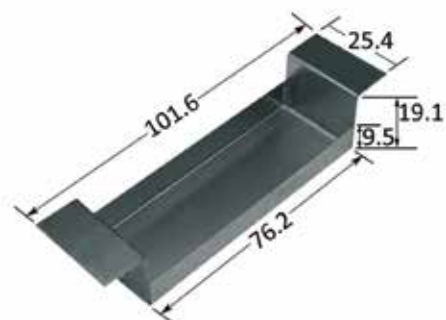

P/N	VOLTS	AMPS	WATTS	TEMP.
SB-4A	2.83	479	1356	1600°C
0.005 Ta				



P/N	VOLTS	AMPS	WATTS	TEMP.
SB-4B	2.83	479	1356	1600°C
0.005 Ta				

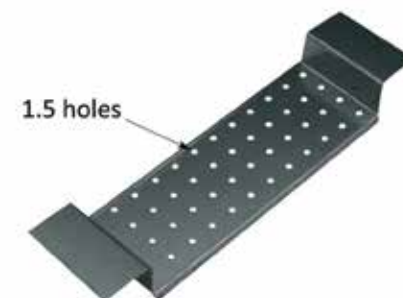

P/N	VOLTS	AMPS	WATTS	TEMP.
SB-5	2.96	371	1098	1600°C
0.010 Ta				



P/N	VOLTS	AMPS	WATTS	TEMP.
SB-5A	2.12	380	806	1600°C
0.005 Ta				



P/N	VOLTS	AMPS	WATTS	TEMP.
SB-5B	2.12	380	806	1600°C
0.005 Ta				

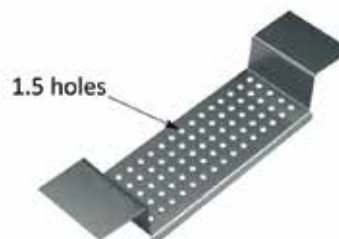

All dimensions are in mm.

P/N	VOLTS	AMPS	WATTS	TEMP.
SB-6	3.58	280	1002	1600°C
0.005 Ta				

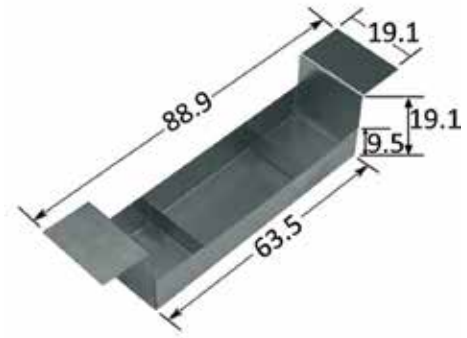

P/N	VOLTS	AMPS	WATTS	TEMP.
SB-6A	2.69	310	834	1600°C
0.005 Ta				



P/N	VOLTS	AMPS	WATTS	TEMP.
SB-6B	2.69	310	834	1600°C
0.005 Ta				

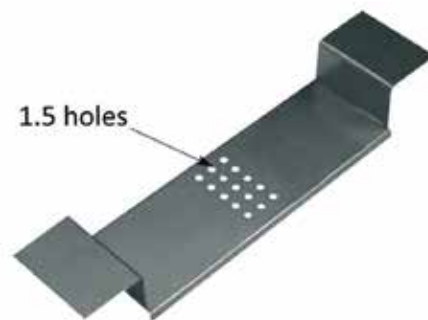

Ta: Tantalum.
All dimensions are in mm.

Folded Baffled Box Sources

P/N	VOLTS	AMPS	WATTS	TEMP.
SB-7A-.005Mo	1.21	547	662	1400°C
SB-7A-.005Ta	2.28	572	1304	1600°C
SB-7A-.010Mo	1.08	705	761	1400°C
SB-7A-.010Ta	2.10	680	1428	1600°C
SB-7B-.005Mo	1.21	547	662	1400°C
SB-7B-.005Ta	2.28	572	1304	1600°C
SB-7C-.005Mo	1.21	547	662	1400°C
SB-7C-.005Ta	2.28	572	1304	1600°C
SB-8A-.005Mo	1.44	850	1224	1400°C
SB-8A-.005Ta	2.51	880	2209	1600°C
SB-8A-.010Mo	1.39	1042	1448	1400°C
SB-8A-.010Ta	2.36	115	2631	1600°C
SB-8B-.005Mo	1.44	850	1224	1400°C
SB-8B-.005Ta	2.51	880	2209	1600°C
SB-8C-.005Mo	1.44	850	1224	1400°C
SB-8C-.005Ta	2.51	880	2209	1600°C

P/N	VOLTS	AMPS	WATTS	TEMP.
SB-9A-.005Mo	1.87	731	1367	1400°C
SB-9A-.005Ta	3.44	750	2580	1600°C
SB-9A-.010Mo	1.62	890	1442	1400°C
SB-9A-.010Ta	3.40	998	3393	1600°C
SB-9B-.005Mo	1.87	731	1367	1400°C
SB-9B-.005Ta	3.44	750	2580	1600°C
SB-9C-.005Mo	1.87	731	1367	1400°C
SB-9C-.005Ta	3.44	750	2580	1600°C
SB-10A-.005Mo	2.11	1222	2578	1400°C
SB-10A-.005Ta	3.66	1220	4465	1600°C
SB-10A-.010Mo	2.02	1530	3091	1400°C
SB-10A-.010Ta	3.37	1550	5224	1600°C
SB-10B-.005Mo	2.11	1222	2578	1400°C
SB-10B-.005Ta	3.66	1220	4465	1600°C
SB-10C-.005Mo	2.11	1222	2578	1400°C
SB-10C-.005Ta	3.66	1220	4465	1600°C

All dimensions are in mm.

P/N	BL	W	H	OL	P	VOL.
SB-7	44.45	25.4	19.05	88.9	1.53 60 holes 4 x 15 rows	21cc
SB-8	44.45	38.1	25.4	88.9	1.53 70 holes 5 x 15 rows	43cc
SB-9	76.2	35.05	19.05	120.65	1.53 115 holes 5 x 23 rows	50cc
SB-10	69.85	50.8	31.75	101.6	3.05 65 holes 5 x 13 rows	112cc

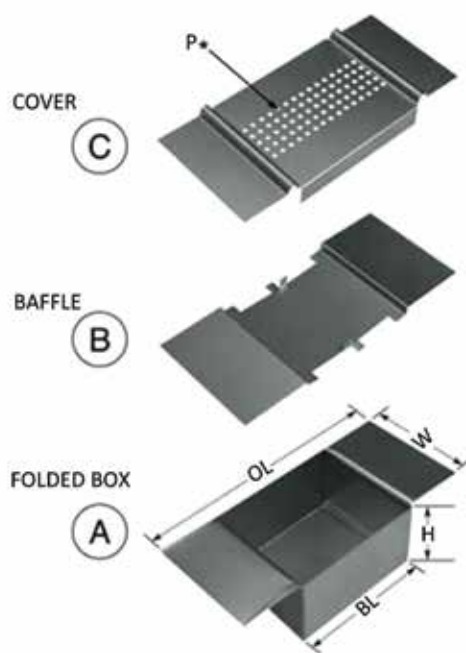

All dimensions are in mm.

P* single hole sizes available on request.

STANDARD MATERIALS		
	Standard	Al ₂ O ₃ coated
C	0.005" / Mo or Ta	0.005" or 0.010" / Mo or Ta
B	0.005" / Mo or Ta	Normally not used
A	0.005" or 0.010" / Mo or Ta	0.010" / Mo or Ta

ORDER INFORMATION

EXAMPLE: SB-10-C-010 Ta-AO, MODIFIED, 3/4 DIA. HOLE IN CENTER

BASIC PART NUMBER

PART (COVER, BAFFLE BOX)

MATERIAL THICKNESS & TYPE

USE ONLY FOR AL₂O₃ COATED PARTS

LIST ANY MODIFICATIONS

Mo: Molybdenum, Ta: Tantalum.

All dimensions are in mm.

Baffled Box Sources for SiO, ZnS

The "Baffled Box" Silicon Monoxide Source, SiO source, has proven to be an extremely successful method of depositing Silicon Monoxide. Source material is positioned in the boat within separate cavities, when heated it follows an indirect path through a series of baffles and then out of the exhaust chimney. The substrate cannot see the bulk material at any time. This essentially eliminates any chance of spitting and streaming which causes pinhole type defects. Many of the sources shown are available with up, down or horizontal exhaust ports.

Material: Tantalum

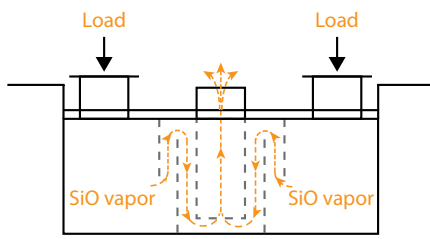

UP EVAPORATION

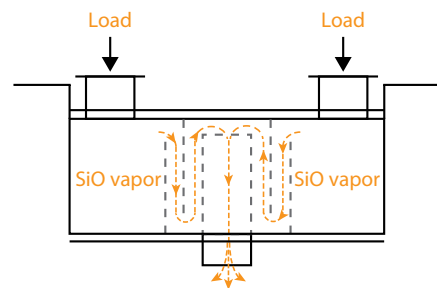

DOWN EVAPORATION

P/N	VOLTS	AMPS	WATTS	TEMP.
SM-8	1.08	255	275	1200°C

3,5 GRAM



500 Watts

P/N	VOLTS	AMPS	WATTS	TEMP.
SM-9	1.00	242	242	1200°C

The SM-9 has the same dimensions as the SM-8 shown above. The internal baffles are reversed allowing the source to be mounted in an inverted position, exhaust port pointing down.

All dimensions are in mm.

P/N	VOLTS	AMPS	WATTS	TEMP.
SM-10	1.25	226	282	1200°C

5 GRAM

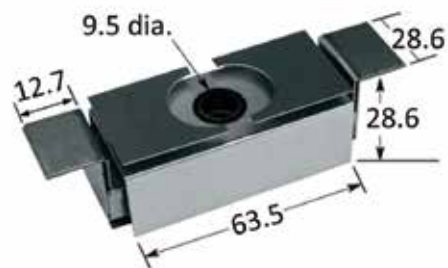

600 Watts

The SM-11 has the same dimensions as the SM-10 shown above. The internal baffles are reversed allowing the source to be mounted in an inverted position, exhaust port pointing down.

P/N	VOLTS	AMPS	WATTS	TEMP.
SM-11	1.26	236	297	1200°C

P/N	VOLTS	AMPS	WATTS	TEMP.
SM-12	1.36	283	385	1200°C

10 GRAM

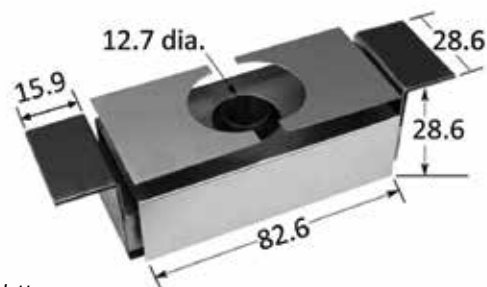

750 Watts

The SM-13 has the same dimensions as the SM-12 shown above. The internal baffles are reversed allowing the source to be mounted in an inverted position, exhaust port pointing down.

P/N	VOLTS	AMPS	WATTS	TEMP.
SM-13	1.60	318	509	1200°C

P/N	VOLTS	AMPS	WATTS	TEMP.
SM-14	1.66	340	564	1200°C

20 GRAM

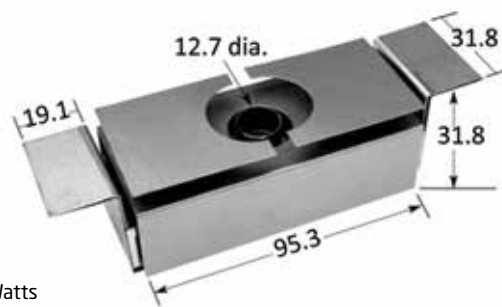

950 Watts

The SM-15 has the same dimensions as the SM-14 shown above. The internal baffles are reversed allowing the source to be mounted in an inverted position, exhaust port pointing down.

P/N	VOLTS	AMPS	WATTS	TEMP.
SM-15	1.70	349	593	1200°C

All dimensions are in mm.

P/N	VOLTS	AMPS	WATTS	TEMP.
SM-16	2.06	357	735	1200°C

40 GRAM

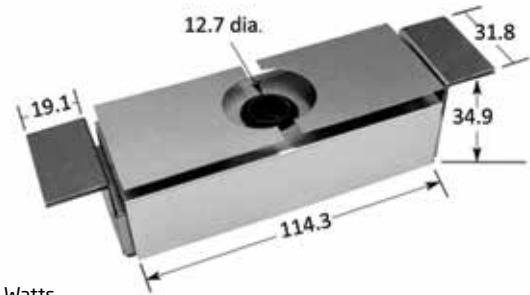

1100 Watts

The SM-17 has the same dimensions as the SM-16 shown above. The internal baffles are reversed allowing the source to be mounted in an inverted position, exhaust port pointing down.

P/N	VOLTS	AMPS	WATTS	TEMP.
SM-17	1.86	327	608	1200°C

P/N	VOLTS	AMPS	WATTS	TEMP.
SO-10	1.40	257	360	1200°C

6.5 GRAM

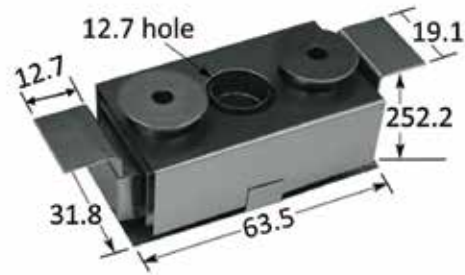

The SO-11 has the same dimensions as the SO-10 shown above, except exhaust port is at bottom of box, pointing down.

P/N	VOLTS	AMPS	WATTS	TEMP.
SO-11	1.40	256	358	1200°C

P/N	VOLTS	AMPS	WATTS	TEMP.
SO-20	0.86	333	286	1200°C

1.5 GRAM



The SO-21 has the same dimensions as the SO-20 shown above, except exhaust port is at bottom of box, pointing down.

P/N	VOLTS	AMPS	WATTS	TEMP.
SO-21	0.91	328	298	1200°C

All dimensions are in mm.

P/N	VOLTS	AMPS	WATTS	TEMP.
SM-22	1.34	246	330	1200°C

6.5 GRAM



P/N	VOLTS	AMPS	WATTS	TEMP.
SM-23	1.31	236	309	1200°C

The S0-23 has the same dimensions as the S0-22 shown above, except exhaust port is at bottom of box, pointing down.

P/N	VOLTS	AMPS	WATTS	TEMP.
S0-24	1.67	264	441	1200°C

13 GRAM



The S0-25 has the same dimensions as the S0-24 shown above, except exhaust port is at bottom of box, pointing down.

P/N	VOLTS	AMPS	WATTS	TEMP.
S0-25	1.58	272	430	1200°C

P/N	VOLTS	AMPS	WATTS	TEMP.
S0-26	1.62	271	439	1200°C

13 GRAM



All dimensions are in mm.

P/N	VOLTS	AMPS	WATTS	TEMP.
S0-32	1.23	217	267	1200°C
S0-34	1.27	289	367	1200°C
S0-36	1.30	373	485	1200°C
S0-38	1.43	447	640	1200°C

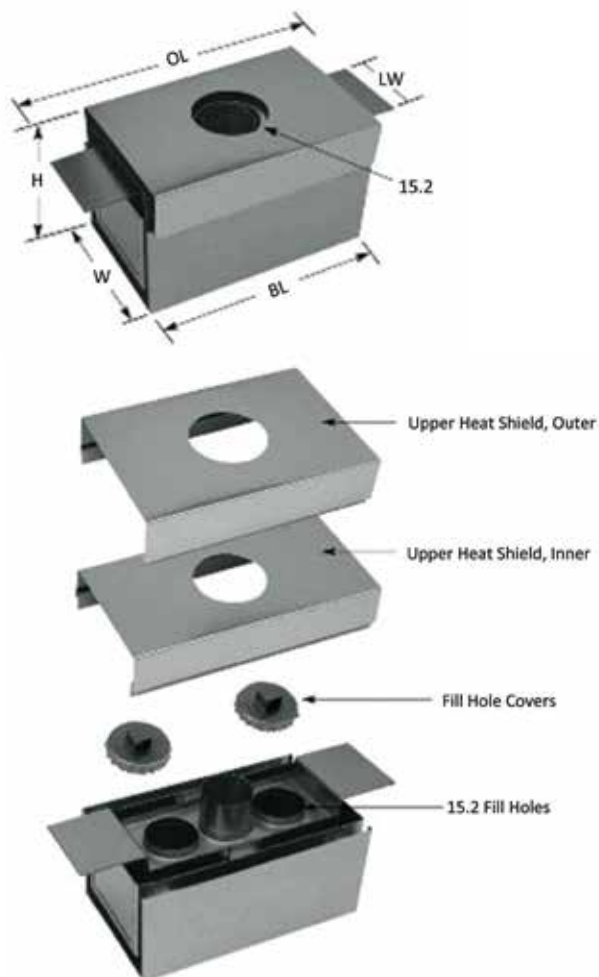

P/N	LH	BL	W	H	OL	LW	VOL.	MATERIAL
S0-32	31.75	73.16	45.72	45.47	101.6	25.4	20 cc	Ta: heater & fill hole covers Nb: lower heat shields Mo: upper heat shields
S0-34	50.8	73.16	45.72	61.47	101.6	25.4	40 cc	
S0-36	50.8	73.16	58.42	61.47	101.6	38.1	60 cc	
S0-38	76.2	73.16	58.42	86.87	101.6	38.1	90 cc	

Available on request: down or side evaporation source

All dimensions are in mm.

HIGH VOLUMES SiO₂/ZnS SOURCES

P/N	VOLTS	AMPS	WATTS	TEMP.
SO-100	3.7	540	1998	1200°C
SO-150	3.9	620	2418	1200°C
SO-200	4.1	860	3526	1200°C
SO-250	4.15	955	3963	1200°C
SO-300	4.2	1075	4515	1200°C
SO-500	4.3	1135	4881	1200°C
SO-800	4.4	1210	5324	1200°C
SO-1000	4.5	1440	6480	1200°C
SO-1500	4.6	1580	7268	1200°C
SO-2000	4.8	1620	7776	1200°C

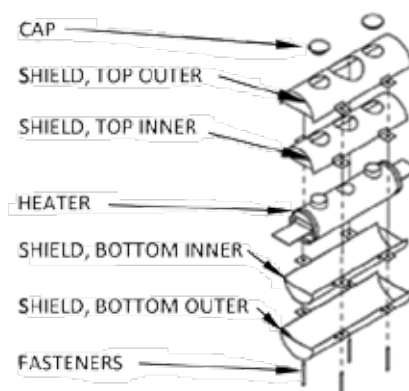
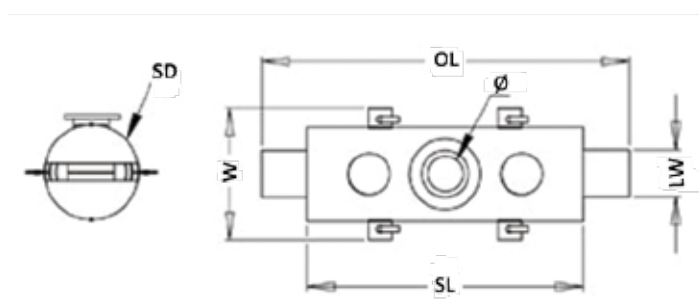

P/N	SL	W	SD	LW	OL	Ø	VOL.
SO-100	149.22	82.55	50.80	19.10	193.68	19.10	100 cc
SO-150	149.22	82.55	50.80	19.10	193.68	19.10	150 cc
SO-200	149.22	95.25	63.50	38.10	206.38	19.10	200 cc
SO-250	149.22	107.95	76.20	57.15	184.15	19.10	250 cc
SO-300	149.22	107.95	76.20	25.40	206.38	19.10	300 cc
SO-500	219.07	107.95	76.20	57.15	279.40	19.10	500 cc
SO-800	219.07	152.40	121.92	50.80	257.81	25.4	800 cc
SO-1000	200.02	152.40	121.92	50.80	279.40	25.4	1000 cc
SO-1500	209.55	161.93	131.78	50.80	304.80	25.4	1500 cc
SO-2000	212.72	182.58	150.83	63.50	292.1	25.4	2000 cc

* Volumes shown are maximums. Recommended usage is 50% of volumes indicated.

All dimensions are in mm.

Microelectronic Sources Tungsten - Tantalum - Molybdenum

SOURCES FOR ROTARY HOLDERS AND SMALL SYSTEMS

P/N	VOLTS	AMPS	WATTS	TEMP.
ME1	1.45	266	386	1600°C
0.005" Ta				

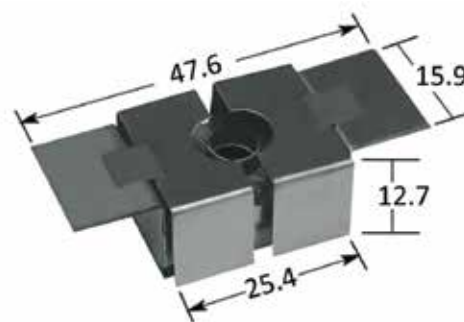

P/N	VOLTS	AMPS	WATTS	TEMP.
ME2	2.52	141	355	1600°C
0.005" Ta				

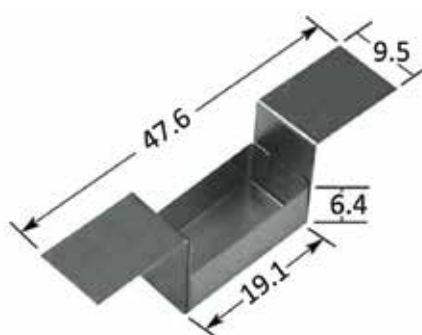

P/N	VOLTS	AMPS	WATTS	TEMP.
ME2A	1.74	176	306	1600°C
0.005" Ta				

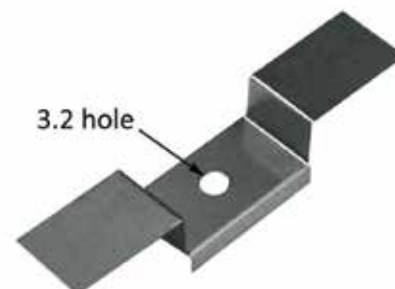

All dimensions are in mm.

P/N	VOLTS	AMPS	WATTS	TEMP.
ME2B	0	0	0	N/A
0.005" Ta				

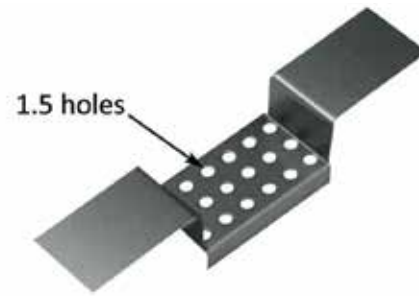

P/N	VOLTS	AMPS	WATTS	TEMP.
ME3-.005Mo	0.94	150	141	1400°C
ME3-.005Ta	1.77	138	244	1600°C
ME3-.005W	2.00	202	404	1800°C

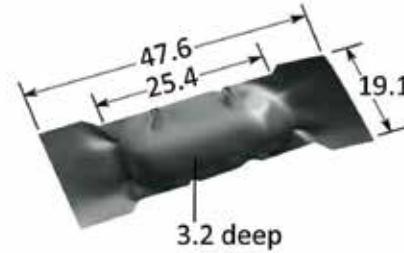

P/N	VOLTS	AMPS	WATTS	TEMP.
ME4-.005Mo	0.94	93	87	1400°C
ME4-.005Ta	1.50	98	147	1600°C
ME4-.005W	1.83	143	262	1800°C

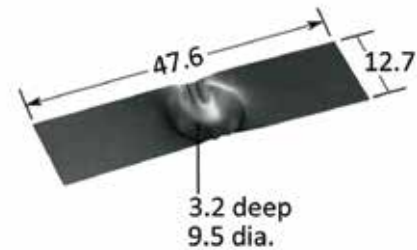

P/N	VOLTS	AMPS	WATTS	TEMP.
ME5-.005Mo	0.85	58	49	1400°C
ME5-.005Ta	1.40	55	77	1600°C
ME5-.005W	1.69	80	135	1800°C



P/N	VOLTS	AMPS	WATTS	TEMP.
ME6A-.005Mo	0.85	102	87	1400°C
ME6A-.005Ta	1.85	95	176	1600°C
ME6A-.005W	1.83	145	265	1800°C

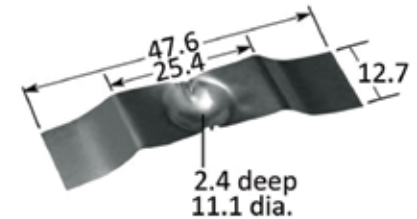

P/N	VOLTS	AMPS	WATTS	TEMP.
ME6B-.005Mo	0.90	97	87	1400°C
ME6B-.005Ta	1.73	96	166	1600°C
ME6B-.005W	1.88	144	271	1800°C

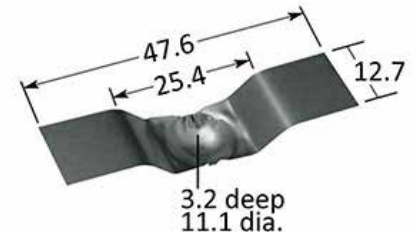

P/N	VOLTS	AMPS	WATTS	TEMP.
ME7-.005Mo	1.12	53	59	1400°C
ME7-.005Ta	1.72	49	84	1600°C
ME7-.005W	2.03	76	154	1800°C

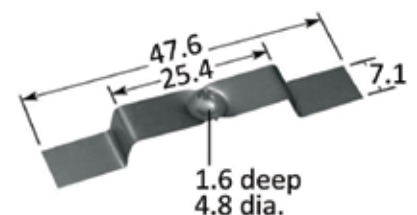

All dimensions are in mm.

P/N	VOLTS	AMPS	WATTS	TEMP.
ME8-.005Mo	1.04	79	82	1400°C
ME8-.005Ta	2.16	93	201	1600°C
ME8-.005W	2.57	129	332	1800°C

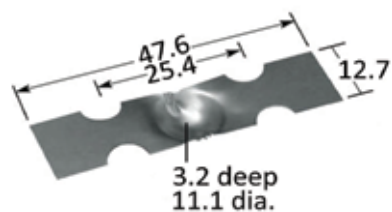

P/N	VOLTS	AMPS	WATTS	TEMP.
ME9-.005Mo	0.80	72	58	1400°C
ME9-.005Ta	1.48	67	99	1600°C
ME9-.005W	1.55	97	150	1800°C

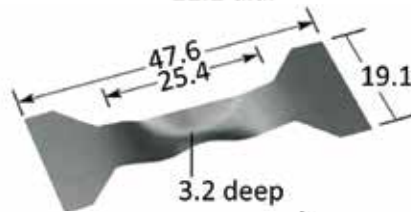

P/N	VOLTS	AMPS	WATTS	TEMP.
ME10-.005Ta	1.07	131	140	1600°C



P/N	VOLTS	AMPS	WATTS	TEMP.
ME11-.030W	3.59	25	90	1800°C
ME11-3X.025W	3.13	44	138	1800°C

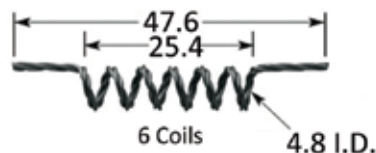

P/N	VOLTS	AMPS	WATTS	TEMP.
ME12-.030W	2.47	27	67	1800°C
ME12-3X.025W	2.30	47	108	1800°C

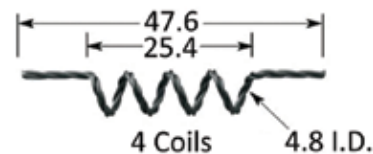

P/N	VOLTS	AMPS	WATTS	TEMP.
ME13A-.030W	1.25	33	41	1800°C
ME13A-3X.025W	1.08	61	66	1800°C

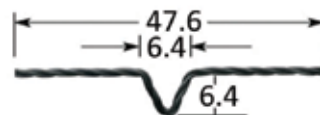

P/N	VOLTS	AMPS	WATTS	TEMP.
ME13B-.030W	1.95	27	53	1800°C
ME13B-3X.025W	1.68	52	87	1800°C

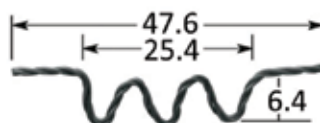

P/N	VOLTS	AMPS	WATTS	TEMP.
ME13C-.030W	1.95	26	51	1800°C
ME13C-3X.025W	1.56	53	83	1800°C

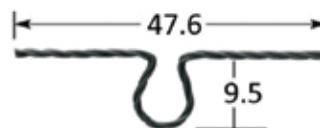

P/N	VOLTS	AMPS	WATTS	TEMP.
ME14-.030W	3.21	24	77	1800°C
ME14-.040W	2.90	36	104	1800°C

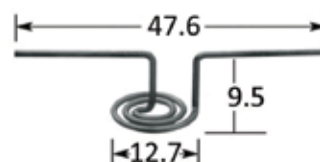

P/N	VOLTS	AMPS	WATTS	TEMP.
ME15-.030W	4.18	23	96	1800°C
ME15-.040W	3.63	34	123	1800°C



All dimensions are in mm.

P/N	VOLTS	AMPS	WATTS	TEMP.
ME16A-030W	2.48	23	57	1800°C
ME16A-3X.025W	2.30	39	90	1800°C

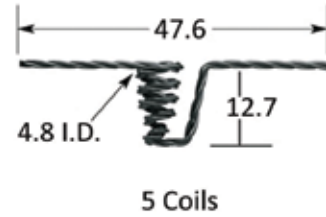

P/N	VOLTS	AMPS	WATTS	TEMP.
ME16B-030W	2.90	23	67	1800°C
ME16B-3X.025W	2.66	42	112	1800°C

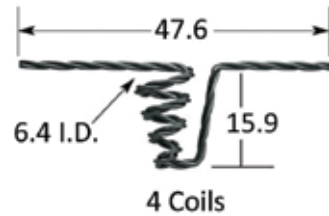

P/N	VOLTS	AMPS	WATTS	TEMP.
ME16C-030W	3.77	23	87	1800°C
ME16C-3X.025W	3.54	43	152	1800°C

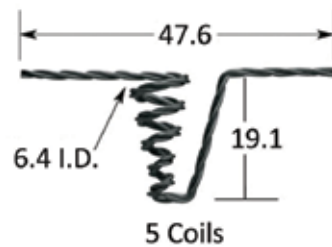

P/N	VOLTS	AMPS	WATTS	TEMP.
ME16D-030W	5.96	21	125	1800°C
ME16D-3X.025W	5.51	40	220	1800°C

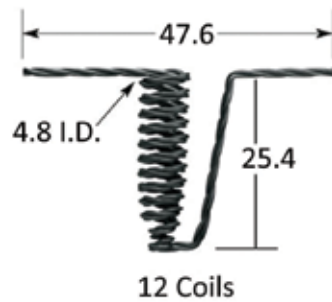

P/N	VOLTS	AMPS	WATTS	TEMP.
ME16E-040W	4.25	32	136	1800°C
ME16E-3X.025W	5.00	44	220	1800°C

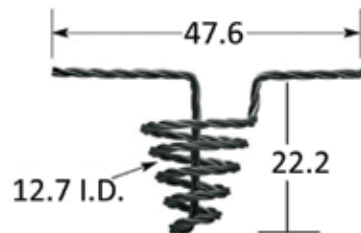

P/N	VOLTS	AMPS	WATTS	TEMP.
ME17-030W	4.93	22	108	1800°C
ME17-3X.025W	4.57	40	183	1800°C

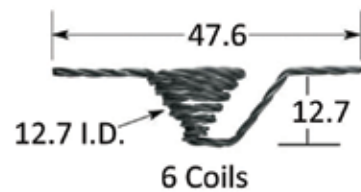

P/N	VOLTS	AMPS	WATTS	TEMP.
ME18A-3X.025W	6.56	48	315	1800°C
ME18A-3X.030W	5.00	55	275	1800°C

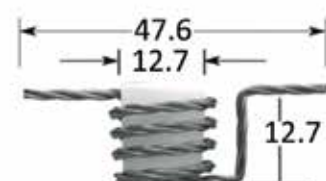

All dimensions are in mm.

P/N	VOLTS	AMPS	WATTS	TEMP.
ME18B-3X.025W	4.70	43	202	1800°C
ME18B-3X.030W	4.25	56	238	1800°C

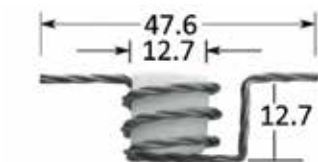

P/N	VOLTS	AMPS	WATTS	TEMP.
ME21-.005Mo	0.94	147	138	1400°C
ME21-.005Ta	1.75	141	247	1600°C
ME21-.005W	1.96	213	417	1800°C



P/N	VOLTS	AMPS	WATTS	TEMP.
ME22	1.87	196	367	1600°C
0.005" Ta				

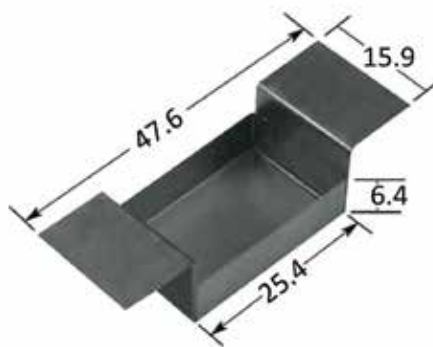

P/N	VOLTS	AMPS	WATTS	TEMP.
ME22A	1.45	265	384	1600°C
0.005" Ta				

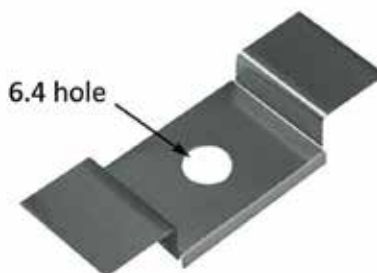

P/N	VOLTS	AMPS	WATTS	TEMP.
ME22B	1.09	293	319	1200°C
0.005 Ta				

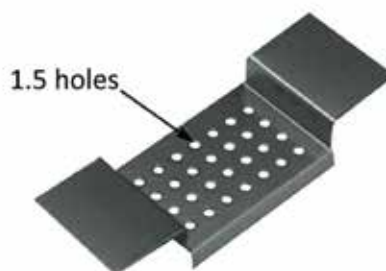

P/N	VOLTS	AMPS	WATTS	TEMP.
ME23-.005Mo	0.79	251	198	1400°C
ME23-.005Ta	1.51	215	325	1600°C
ME23-.005W	1.40	327	458	1800°C
Covered boat source				



P/N	VOLTS	AMPS	WATTS	TEMP.
ME24-.005Mo	0.83	248	206	1400°C
ME24-.005Ta	1.47	230	338	1600°C
ME24-.005W	1.66	322	535	1800°C
Covered boat source				

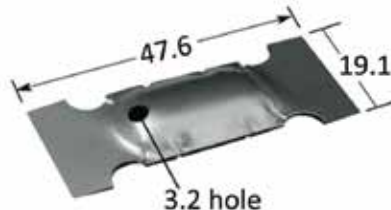

Mo: Molybdenum, Ta: Tantalum, W: Tungsten

All dimensions are in mm.

Chrome Plated Tungsten Rods

We offer an effective, user friendly way to evaporate Chromium. The Chrome plated Tungsten rods are used for thin films of Chromium in the electronics and optics industries. The advantage of using Chrome rods over Chrome chips are better thermal efficiency, regulation of film thickness and elimination of spitting and spalling which can cause pinhole type defects.

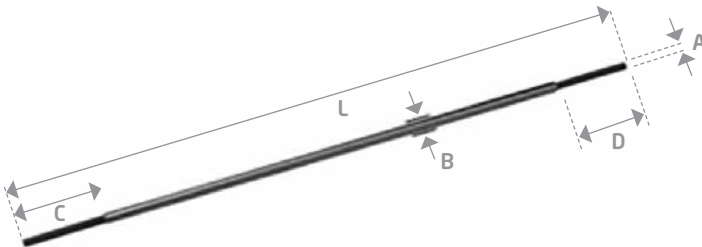

The rods are offered in the below configuration as standards.

P/N	VOLTS	AMPS	WATTS	TEMP.	C&D	L	A	B
CRW-1M	1.05	78	82	1800°C	12.7	50.8	1.27	1.78
CRW-2M	2.02	78	158	1800°C	12.7	101.6	1.27	1.78
CRW-3M	2.40	77	185	1800°C	12.7	152.4	1.27	1.78

All dimensions are in mm.

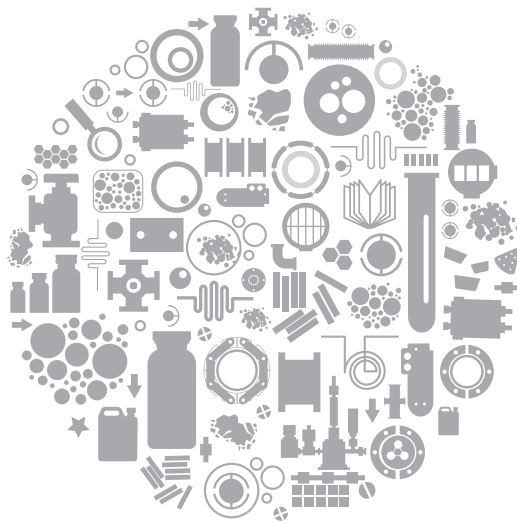

neyco

30 avenue de la Paix
92170 Vanves - France
Tel: +33(0)1 41 90 50 50
Fax: +33(0)1 41 90 50 51

www.neyco.fr



Materials | 2018-1

neyco



MATERIALS SUBSTRATES

- Silicon Wafers J 04
- Single Crystal Substrates..... J 09
- Glass & Fused Quartz Substrates..... J 46
- Ceramic Substrates J 52
- Glassy Carbon Substrates..... J 53
- HOPG & Mica Substrates J 55
- Wafer Tweezers..... J 57
- Vacuum Pen Dedicated to Fragile Substrates . J 60
- Thermo Patch - Vacuum Environment..... J 61

NEYCO has a complete range of substrates for a wide variety of applications, including Semiconductor, Biotechnology, Nanotechnology, and MEMS. NEYCO is your one stop source for advanced materials for both R&D laboratory use and industry production.



STANDARD SINGLE CRYSTAL SUBSTRATE PARAMETERS

Substrates and wafers are manufactured by a technology, which is specially adapted to the respective material. Additionally we produce substrates and wafers customer-specific in all possible orientations, sizes and geometries and with smaller tolerance.

Orientations	(100), (111), (110) for cubic crystals (110), (001) for tetragonal crystals (0001), (1-102), (11-20), (10-10) for hexagonal crystals (110), (001) for orthorhombic crystals other orientations on request Standard: edges are oriented
Tolerance of orientation	Maximum 30' ; typical < 20' higher precision on request
Standard sizes	10x10 mm, 10x5 mm, 12.7x12.7 mm, 15x15 mm, 20x20 mm, 25x25 mm, \varnothing 1", \varnothing 2", \varnothing 3" other sizes on request
Tolerance of sizes	+0/-0.05 mm
Thickness	0.5 mm, 1.0 mm (standard) other thicknesses down to 0.1 mm on request
Tolerance of thickness	+0.05/-0.05 mm
Polish	One side, two sides optical polish of lateral sides (cylinders) on request
Surface quality	Scratchfree at magnification of 50
Roughness: (at $\lambda_{\text{cutoff}} = 0.08 \text{ mm}$)	Ra: typ. 0.5 nm Rq: typ. 1.0 nm Rt: typ. 2.0 nm
Parallelity	Typ. better than 10'
Flatness	Max. 1 μm /10 mm (test region 98% of the wafer area)

Micro-roughness measured with Kugler Interferometermicroscope (lateral resolution: 0.64 μm , vertical resolution (theoretically): 0.01 nm).

Silicon Wafers

MATERIALS CHARACTERISTICS

Silicon wafers are cut from silicon single crystal using internal diameter diamond discs. Silicon wafers are lapped of both sides with abrasive mixture. After cutting or lapping the wafers are washed in ultrasonic washers or undergo active washing. The wafers' edges are mechanically rounded. Silicon wafers are etched in acid mixture or alkaline. Wafers surface is alkaline or acid etched according to the customer's request. Active sides of the wafers (for single side polished wafers) or both sides (for two sides polished wafers) are chemo-mechanically polished.

The mentioned parameters are dealing with our standard production. On the customer's request we are ready to discuss orders for wafers with some other parameters, for instance:

- Low radial resistivity variation (RRV) combined with the uniform distribution of dopants in the crystal (this parameter depends on shape of phase boundary and the

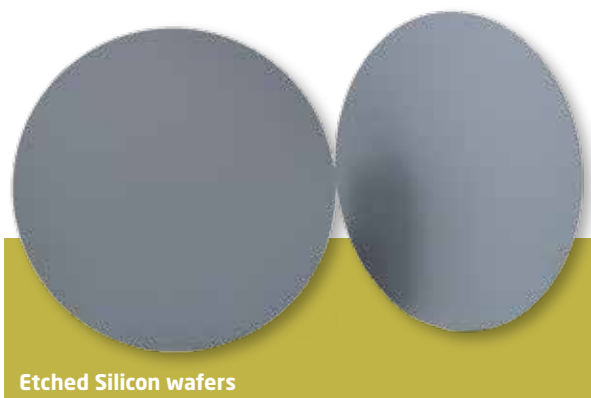

Etched Silicon wafers

phenomena in the boundary layer during monocrystallization process).

- Perfect crystallographic structure of material (free from swirls, with dislocations density lower than recommended by SEMI standard - 500/cm²).
- Low oxygen concentration ($O_2 < 30$ ppm).
- Tolerance of orientation better than 0.10°.
- Very good polished surface (one or both sides polished depending on technology and the type of products).



Polished Silicon wafers

STANDARD SPECIFICATIONS

CRYSTAL GROWTH						
Growth method	Czochralski (CZ) Floating zone (FZ)					
Orientation	<100>, <111>, <110>					
Diameters	1" to 300 mm					
CRYSTALLOGRAPHIC PROPERTIES						
Crystal structure	Cubic a = 0.543 nm					
Dopant available	P-type: Boron N-type: Phosphorus, Antimony or Arsenic					
PHYSICAL PROPERTIES						
Density	2.329 g.cm ⁻³					
Melting point	1417°C					
Hardness	7 Mohs					
Thermal expansion	2.3 - 4.7.10 ⁻⁶ K ⁻¹ (as per doping specification)					
Resistivity range	0.001 - 10 000 Ω.cm					
Band gap (at 273 K)	1.106 eV					
Thermal conductivity	147 W.m ⁻¹ .K ⁻¹					
Carrier mobility	$\mu_e = 1350 \text{ cm}^2 \cdot \text{V}^{-1} \cdot \text{s}^{-1}$ $\mu_h = 480 \text{ cm}^2 \cdot \text{V}^{-1} \cdot \text{s}^{-1}$					
Conductivity type	P-type or N-type					
CHEMICAL PROPERTIES						
Solubility in water	0.005 g/100 cm ³					
Solubility in acids	Soluble					
Solubility in organic solvents	Insoluble					
OPTICAL PROPERTIES						
Absorption coefficient	0.01 cm ⁻¹ at 5 μm					
Transmission range (thickness 2 mm)	1.2 - 15.0 μm					
Refractive index n	3.0 μm	5.0 μm	6.0 μm	7.0 μm	8.0 μm	10.0 μm
	3.432	3.422	3.420	3.419	3.418	3.417
OTHER PROPERTIES						
Flat / notch	Semi STD, Single flat, None					
Surface finish	SSD (Single side polished), DSP (Double side polished), ascut, lapped, etched					
Roughness	Ra <0.5 nm, Ra <4 nm					

SI WAFERS PRIMARY & SECONDARY FLATS

- Primary flat: The flat of longest length located in the circumference of the wafer. The primary flat has a specific crystal orientation relative to the wafer surface; major flat.
- Secondary flat: Indicates the crystal orientation and doping of the wafer. The location of this flat varies.

Flats dimensions

WAFERS DIAMETER	LENGTH OF PRIMARY FLAT	LENGTH OF SECONDARY FLAT
2"	15.9 mm ± 1 mm	7.9 mm ± 1.5 mm
3"	22.2 mm ± 2 mm	11.1 mm ± 1.6 mm
4"	32.5 mm ± 2.5 mm	18 mm ± 2 mm

Flats locations

Orientation : $\langle 100 \rangle$ flat at 180° for n-type and 90° for p-type

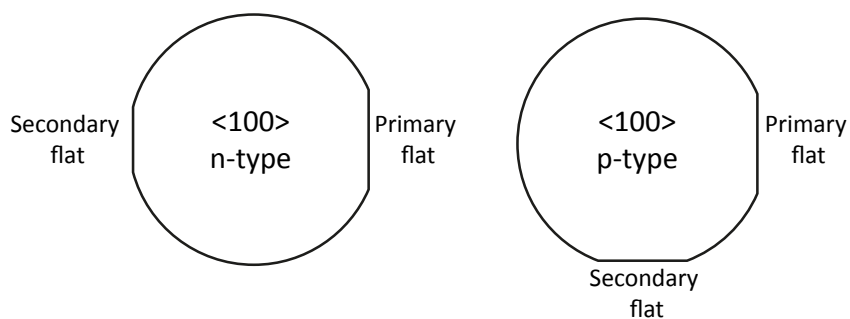

Orientation : $\langle 111 \rangle$ flat at 45° for n-type and no secondary for p-type

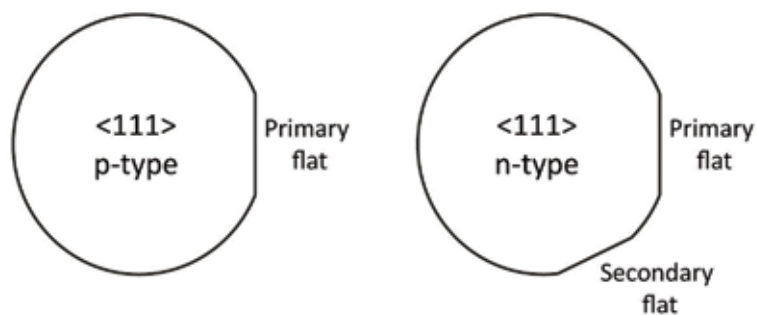

TRANSMISSION SPECTRUM (high resistivity Si)

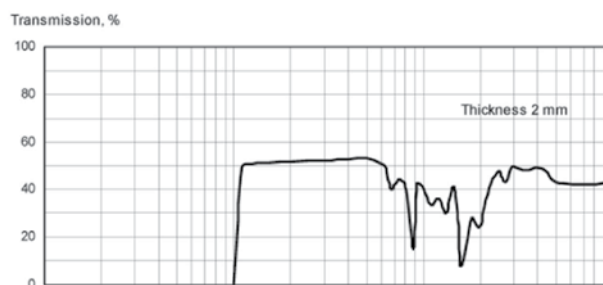

RECOMMENDED APPLICATIONS

Wafer Resistivity ($\Omega\cdot\text{cm}$)	< 0.05	1 - 5	6 - 12	> 30
Application	Epitaxial substrate	Solar cell	IC, OE devices or sensors	Special device or component

SERVICES ON SILICON WAFERS

THERMAL OXIDATION AND NITRURATION

We offer a service of thermal oxidation (by dry or wet way) on our wafers. The oxidation thickness can be from 50 nm to 5 μm . The oxidation on one side is also possible.

We also offer a service of nitriding Si_3N_4 (classical at 800°C or low stress at 835°C) on our wafers.

Thickness: from 50 nm to 5 μm .



Thermal nitriding on Si wafer

VACUUM COATINGS ON WAFER

We make special vacuum coatings on wafers (for example: precoating of Chromium or Titanium before a thin film of Gold, or any other E-beam evaporated or sputtered material).

DICING OF WAFERS

We offer the dicing of the wafers in square or rectangular parts.

For examples:

- 10 mm x 10 mm
- 5 mm x 5 mm
- 5 mm x 10 mm,...

SINGLE WAFER CONTAINER

Single Silicon wafer carrier, or for other delicate flat substrates, from 1" to 6".

Material: natural PP

Color: Transparent

Packaging:

- 1 piece
- per 25 clean room bagged.

Contact us for your specific needs



Single wafer Container

P/N	WAFERS SIZE	PACKAGING
BWA1S	1"	1 piece
BWA2S	2"	
BWA3S	3"	
BWA4S	4"	
BWA5	5"	
BWA6	6"	
BWA1-25	1"	25 pieces
BWA15-25	1.5"	
BWA2-25	2"	
BWA25-25	2.5"	
BWA3-25	3"	
BWA4-25	4"	
BWA5-25	5"	
BWA6-25	6"	

Single Crystal Substrates

- Al₂O₃ Sapphire substrate J 10
- BaF₂ Barium Fluoride substrate J 11
- BaTiO₃ Barium Titanate substrate J 12
- CaF₂ Calcium Fluoride substrate J 13
- CaNdAlO₄ (CNAO) Calcium Neodymium Aluminate substrate J 14
- CdS Cadmium Sulfide substrate J 15
- CdSe Cadmium Selenide substrate J 15
- CdTe Cadmium Telluride substrate J 16
- CoO Cobalt Oxide substrate J 17
- Cr₂O₃ Chromium Oxide substrate J 17
- GaAs Gallium Arsenide substrate J 18
- GaP Gallium Phosphide substrate J 19
- Gd₃Ga₅O₁₂ Gadolinium Gallium Garnet (GGG) substrate J 20
- Ge Germanium substrate J 21
- InAs Indium Arsenide substrate J 22
- InP Indium Phosphide substrate J 23
- LaAlO₃ Lanthanum Aluminate substrate J 24
- LiAlO₂ Lithium Aluminate substrate J 25
- LiF Lithium Fluoride substrate J 25
- LiGaO₂ Lithium Gallate substrate J 27
- LiNbO₃ Lithium Niobate substrate J 27
- Lithium-Strontium-Aluminum-Tantalum-Oxide (LSAT) substrate J 28
- MgAl₂O₄ Magnesium Aluminum Oxide substrate J 29
- MgF₂ Magnesium Fluoride substrate J 30
- MgO Magnesium Oxide substrate J 31
- MnO Manganese Oxide substrate J 32
- NaCl Sodium Chloride substrate J 33
- NdGaO₃ Neodymium Gallate (NGO) substrate J 34
- NiO Nickel Oxide substrate J 34
- SiO₂ Quartz substrate J 35
- SrLaAlO₄ Strontium Lanthanum Aluminate substrate J 36
- SrLaGa₃O₇ Strontium Lanthanum Gallate substrate J 36
- SrLaGaO₄ Strontium Lanthanum Gallate substrate J 37
- SrTiO₃ Strontium Titanate substrate J 38
- TiO₂ Titanium Oxide (Rutile) substrate J 39
- Y₃Al₅O₁₂ Yttrium Aluminium Garnet (YAG) substrate J 40
- YAlO₃ Yttrium Aluminate (YAP) substrate J 41
- Ytria Stabilized Zirconia (YSZ) substrate J 41
- ZnO Zinc Oxide substrate J 42
- ZnS Zinc Sulfide substrate J 43
- ZnSe Zinc Selenide substrate J 44
- ZnTe Zinc Telluride substrate J 45

Al₂O₃ SAPPHIRE SUBSTRATE

Sapphire (single crystal of Al₂O₃) is being used extensively as a substrate for III-V nitrides and for many other epitaxial films. Single crystal sapphire wafer plays an increasingly important role as a material for blue LED, high Tc superconductor and microwave applications, due to its high strength, high anti-corrosion, high anti-abrasion, low dielectric loss and good electrical insulation.

NEYCO provides sapphire substrates with complete orientation options including C plane, A plane, R plane and M plane, in diameter range from 1" to 4", square substrate is also available as well, size from 10 x 10 mm to 100 x 100 mm. NEYCO can offer EPI ready grade sapphire wafer for your epitaxial growth.

FEATURES

- High working temperature
- Good thermal conductivity
- Superior mechanical properties
- High anti corrosion
- Stable dielectric constant & low dielectric loss
- Excellent light transmission

APPLICATIONS

- Blue LED substrate
- Superconductor substrate
- Electronics and optoelectronics
- UV and IR optics

STANDARD SPECIFICATIONS

CRYSTAL GROWTH	
Growth method	Czochralski (CZ)
Maximum size	Ø 4"
CRYSTALLOGRAPHIC PROPERTIES	
Crystal structure	Hexagonal a = 0.477 nm c = 1.304 nm
Color	Colourless
PHYSICAL PROPERTIES	
Density	3.98 g.cm ⁻³
Melting point	2052°C
Hardness	9 Mohs
Thermal expansion	Vertical c-axis: 6.2.10 ⁻⁶ K ⁻¹ Parallel c-axis: 5.4.10 ⁻⁶ K ⁻¹
Thermal conductivity	Vertical c-axis: 23.1 W.m ⁻¹ .K ⁻¹ Parallel c-axis: 25.2 W.m ⁻¹ .K ⁻¹
Heat capacity	761 J.kg ⁻¹ .K ⁻¹
Dielectric constant	Vertical c-axis: 9.4 Parallel c-axis: 11.5
Loss Tangent at 10 GHz	Vertical c-axis: 8.6.10 ⁻⁸ Parallel c-axis: 3.10 ⁻⁸
CHEMICAL PROPERTIES	
Solubility in water	98.10 ⁻⁶ g/100 cm ³
Solubility in acids	Insoluble
Solubility in organic solvents	Not declarate

OPTICAL PROPERTIES				
Absorption coefficient	0.2 cm ⁻¹ at 0.2 μm 0.02 cm ⁻¹ at 0.4 μm 0.46 cm ⁻¹ at 5 μm			
Transmission range (thickness 10 mm)	0.17 - 5.0 μm			
Refractive index n	1 μm	2 μm	3 μm	4 μm
	1.7545	1.7374	1.7015	1.6748

TRANSMISSION SPECTRUM

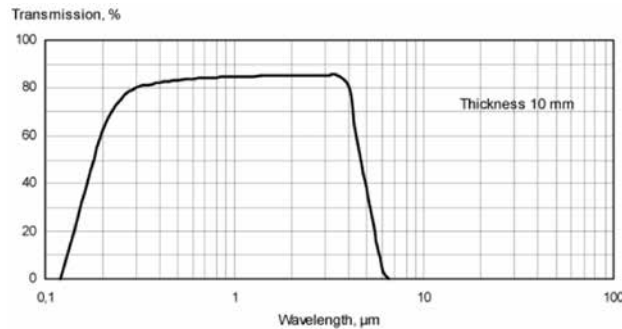

BaF₂ BARIUM FLUORIDE SUBSTRATE

APPLICATIONS

IR and UV window, prism, substrate.

STANDARD SPECIFICATIONS

CRYSTAL GROWTH	
Growth method	Stockbarger technique
Maximum size	Ø 150 mm
CRYSTALLOGRAPHIC PROPERTIES	
Crystal structure	Cubic a = 0.6196 nm
Cleavage plane	<111>
PHYSICAL PROPERTIES	
Density	4.83 g.cm ⁻³
Melting point	1354°C
PHYSICAL PROPERTIES	
Hardness	3 Mohs
Thermal expansion	16.5 - 19.2 x 10 ⁻⁶ K ⁻¹

PHYSICAL PROPERTIES						
Thermal conductivity	7.1 W.m ⁻¹ .K ⁻¹					
Specific heat capacity	456 J.kg ⁻¹ .K ⁻¹					
CHEMICAL PROPERTIES						
Solubility in water	0.17 g/100 cm ³					
Solubility in acids	Soluble					
Solubility in organic solvents	Not declare					
OPTICAL PROPERTIES						
Absorption coefficient	0.20 cm ⁻¹ at 0.2 μm 0.08 cm ⁻¹ at 0.4 μm 0.13 cm ⁻¹ at 10.6 μm					
Refractive index n	0.2 μm	0.5 μm	1.0 μm	5.0 μm	10.0 μm	12.0 μm
	1.5573	1.4779	1.4686	1.4511	1.4014	1.3696

TRANSMISSION SPECTRUM

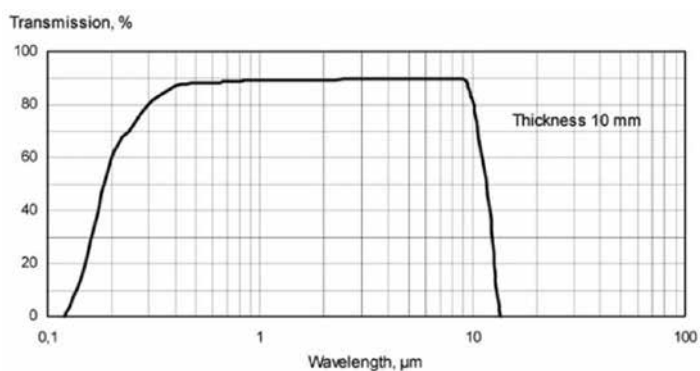

BaTiO₃ BARIUM TITANATE SUBSTRATE

STANDARD SPECIFICATIONS

CRYSTAL GROWTH	
Growth method	Czochralski (CZ)
Maximum size	10 x 10 mm
CRYSTALLOGRAPHIC PROPERTIES	
Crystal structure	Tetragonal a = 0.3992 nm c = 0.4036 nm
PHYSICAL PROPERTIES	
Density	8.82 g.cm ⁻³
Melting point	1600°C
Hardness	5 Mohs

CaF₂ CALCIUM FLUORIDE SUBSTRATE

APPLICATIONS

IR windows and lens, prism.

STANDARD SPECIFICATIONS

CRYSTAL GROWTH						
Growth method	Stockbarger technique					
Maximum size	Ø 200 mm					
CRYSTALLOGRAPHIC PROPERTIES						
Crystal structure	Cubic a = 0.5462 nm					
Cleavage plane	<111>					
PHYSICAL PROPERTIES						
Density	3.18 g.cm ⁻³					
Melting point	1418°C					
Hardness	4 Mohs					
Thermal expansion	16.2 - 19.4 x 10 ⁻⁶ K ⁻¹					
Thermal conductivity	9.17 W.m ⁻¹ .K ⁻¹					
Specific heat capacity	888 J.kg ⁻¹ .K ⁻¹					
CHEMICAL PROPERTIES						
Solubility in water	0.0016 g/ 100 cm ³					
Solubility in acids	Unessential					
Solubility in organic solvents	Insoluble in acetone					
OPTICAL PROPERTIES						
Transmission range (Thickness 10 mm)	0.15 - 9.0 µm					
OPTICAL PROPERTIES						
Refractive index	0.2 µm	0.5 µm	1.0 µm	5.0 µm	10.0 µm	12.0 µm
	1.4951	1.4365	1.4289	1.3990	1.3002	1.2299
Absorption coefficient	0.10 cm ⁻¹ at 0.2 µm 0.01 cm ⁻¹ at 0.4 µm 0.03 cm ⁻¹ at 2.6-2.9 µm					

TRANSMISSION SPECTRUM

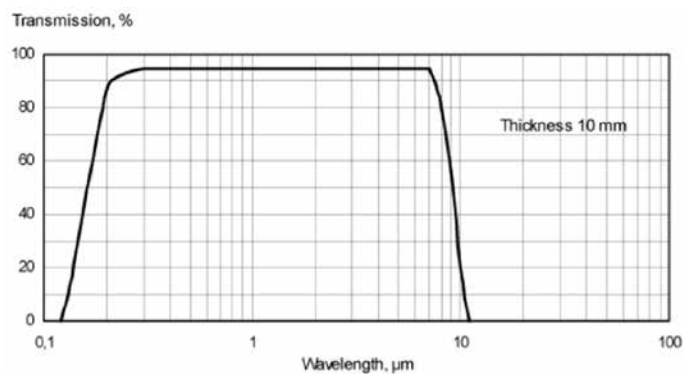

CaNdAlO₄ CALCIUM NEODYMIUM ALUMINATE (CNAO) SUBSTRATE

MATERIAL CHARACTERISTICS

High quality YBaCuO, BiSrCaCuO, Bi(Pb)CaCuO and TlBaCaCuO thin films have been grown on CaNdAlO₄ substrates by different techniques.

STANDARD SPECIFICATIONS

CRYSTAL GROWTH	
Growth method	Czochralski (CZ)
Maximum size	Ø 18 - 20 mm
Standard thickness	0.5 to 1 mm
CRYSTALLOGRAPHIC PROPERTIES	
Crystal structure	Tetragonal a = 0.369 nm c = 2.215 nm
Color	Violet
Twin structure	No
PHYSICAL PROPERTIES	
Density	5.527 g.cm ⁻³
Melting point	1860°C
Thermal expansion	Along a-axis: 8.67.10 ⁻⁶ K ⁻¹ Along c-axis: 1.57.10 ⁻⁵ K ⁻¹
Dielectric constant	20
Loss tangent (at 10 GHz)	2.10 ⁻³
OPTICAL PROPERTIES	
Transmission range	220 to 6670 nm (excluding Nd range)
Refractive index n	1.941

CdS CADMIUM SULFIDE SUBSTRATE

STANDARD SPECIFICATIONS

CRYSTAL GROWTH	
Growth method	Seeded vapour phase growth
Maximum size	Ø 50 mm
CRYSTALLOGRAPHIC PROPERTIES	
Crystal structure	Hexagonal a = 0.4135 nm c = 0.6749 nm
PHYSICAL PROPERTIES	
Density	4.82 g.cm ⁻³
Melting point	1475°C
Hardness	4 Mohs
Thermal expansion	4.2.10 ⁻⁶ K ⁻¹
Resistivity range	> 10 ⁸ Ω.cm (high resistivity) < 10 ¹ Ω.cm (low resistivity)
Band gap at 300 K	2.53 eV
Thermal conductivity	15.9 W.m ⁻¹ .K ⁻¹
Conductivity type	N-type
Carrier concentration	10 ⁹ - 10 ¹⁸ cm ⁻³
Dielectric constant	Vertical c-axis: 8.28 Parallel c-axis: 8.64

CdSe CADMIUM SELENIDE SUBSTRATE

STANDARD SPECIFICATIONS

CRYSTAL GROWTH	
Growth method	Seeded vapour phase growth
Maximum size	Ø 50 mm
CRYSTALLOGRAPHIC PROPERTIES	
Crystal structure	Hexagonal a = 0.431 nm c = 0.7021nm
PHYSICAL PROPERTIES	
Density	5.816 g.cm ⁻³
Melting point	1268°C
Hardness	4 Mohs
Thermal expansion	2.9.10 ⁻⁶ K ⁻¹
Resistivity range	> 10 ⁷ Ω.cm (high resistivity) < 10 ¹ Ω.cm (low resistivity)
Thermal conductivity	3.49 W.m ⁻¹ .K ⁻¹
Band gap at 300 K	1.74 eV
Conductivity type	N-type

CdTe CADMIUM TELLURIDE SUBSTRATE

STANDARD SPECIFICATIONS

CRYSTAL GROWTH						
Growth method	Modified Bridgman (with Cd-reservoir)					
Maximum size	Ø 60 mm					
CRYSTALLOGRAPHIC PROPERTIES						
Crystal structure	Cubic a = 0.6481 nm					
Cleavage	<110>					
PHYSICAL PROPERTIES						
Density	5.855 g.cm ⁻³					
Melting point	1092°C					
Hardness	3 Mohs					
Thermal expansion	5.7.10 ⁻⁶ K ⁻¹					
Thermal conductivity	6.28 W.m ⁻¹ .K ⁻¹					
Resistivity range	> 10 ⁹ Ω.cm					
Band gap at 300 K	1.5 eV					
Conductivity type	N-type, P-type					
CHEMICAL PROPERTIES						
Solubility in water	Insoluble					
Solubility in acids	Insoluble					
Solubility in organic solvents	Insoluble					
OPTICAL PROPERTIES						
Absorption coefficient	0.001 cm ⁻¹ at 10.6 µm					
Transmission range (thickness 2 mm)	0.9 µm to 24 µm					
Refractive index n	1 µm	5 µm	10 µm	15 µm	20 µm	30 µm
	2.831	2.692	2.679	2.659	2.632	2.559

CoO COBALT OXIDE SUBSTRATE

STANDARD SPECIFICATIONS

CRYSTAL GROWTH	
Growth method	Verneuil
Maximum size	Ø 15mm
CRYSTALLOGRAPHIC PROPERTIES	
Crystal structure	Cubic a = 0.4267 nm
Color	Black
PHYSICAL PROPERTIES	
Density	6.4 g.cm ⁻³
Melting point	1935°C
Hardness (Knoop test)	310 to 345

Cr₂O₃ CHROMIUM OXIDE SUBSTRATE

STANDARD SPECIFICATIONS

CRYSTAL GROWTH	
Growth method	Verneuil
Maximum size	Ø 15 mm
CRYSTALLOGRAPHIC PROPERTIES	
Crystal structure	Hexagonal a = 0.496 nm c = 1.3599 nm
Color	Black
PHYSICAL PROPERTIES	
Density	5.2 g.cm ⁻³
Melting point	2275°C

GaAs GALLIUM ARSENIDE SUBSTRATE

Gallium Arsenide used for lenses and beam splitters provides an alternative to ZnSe in medium and high power CW CO₂ laser systems. It is most useful in applications where toughness and durability are important. Its hardness and strength make it a good choice where dust or

abrasive particles tend to build up on or bombard the optical surfaces. When frequent cleaning by wiping is required, GaAs is excellent. The material is nonhygroscopic, safe to use in laboratory and field conditions and is chemically stable except when in contact with strong acids.

FEATURES

- High mobility
- High frequency
- Low power consumption

APPLICATIONS

- Visible and infrared LED
- Light emitting diodes
- Laser diodes

STANDARD SPECIFICATIONS

CRYSTAL GROWTH										
Growth method	Czochralski (CZ) or Vertical Gradient Freeze									
Maximum size	Ø 4"									
Standard thickness	350 - 625 µm									
CRYSTALLOGRAPHIC PROPERTIES										
Crystal structure	Cubic a = 0.565 nm									
Dopant available	Silicon, Tellurium, Zinc, Chromium									
PHYSICAL PROPERTIES										
Density	5.32 g.cm ⁻³									
Melting point	1238°C									
Hardness (Knoop test)	750									
Thermal expansion	5.8.10 ⁻⁶ K ⁻¹									
Dielectric constant	12.85									
Band gap	1.42 eV									
Thermal conductivity	0.55 W.cm ⁻¹ .K ⁻¹									
Specific heat capacity	0.327 J.g ⁻¹ .K ⁻¹									
Conductivity	Semi-conducting or semi-insulating									
Conductivity type	P-type or N-type									
OPTICAL PROPERTIES										
Absorption coefficient	< 0.02 cm ⁻¹ at 10.6 µm									
Transmission range (thickness 7 µm)	1.0 to 22 µm									
Solubility in water	None									
Refractive index n	8 µm	10 µm	11 µm	13 µm	13.7 µm	14.5 µm	15 µm	17 µm	19 µm	21.9 µm
	3.34	3.13	3.04	2.97	2.89	2.82	2.73	2.59	2.41	2.12

Parameters	Undoped GaAs	Si Doped GaAs	Zn Doped GaAs	Cr Doped GaAs	Te Doped GaAs
Doping	Undoped	Si	Zn	Cr	Te
Conductor type	N, (SI)	N	P	SI	N
Carrier concentration (cm ⁻³)	-	(5 - 15).10 ¹⁷	> 5.10 ¹⁸	-	5 - 20.10 ¹⁷
Resistivity (Ω.cm)	> 1.10 ⁻⁷	-	-	> 5.10 ⁷	-
Mobility (cm ² .V ⁻¹ .s ⁻¹)	> 4500	3000 - 1800	> 50	> 3000	> 1500
E.P.D. (cm ⁻²)	< 5.10 ⁴	1.10 ⁴ - 3.10 ³	< 5.10 ⁴	> 8.10 ⁴	< 3000

TRANSMISSION SPECTRUM

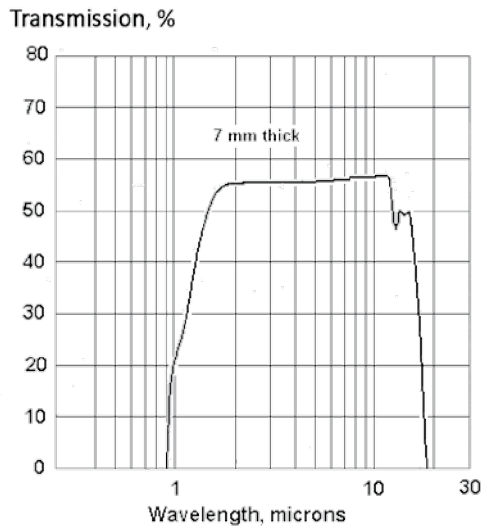

GaP GALLIUM PHOSPHIDE SUBSTRATE

GaP single crystals are grown by the Czochralski technique and are widely used for red, yellow and green LED substrates. NEYCO provides high quality as-cut GaP

wafers for LPE in mass production, and also supplies EPI polished wafers for CVD and MBE applications.

STANDARD SPECIFICATIONS

CRYSTAL GROWTH	
Growth method	Czochralski (CZ)
Maximum size	Ø 2"
Standard thickness	500 µm
CRYSTALLOGRAPHIC PROPERTIES	
Crystal structure	Cubic a = 0.545 nm
PHYSICAL PROPERTIES	
Conductivity	Semi-conducting (SI)
Conductivity type	N-type
Dopant available	Silicon

Dopant	Si doped	Undoped
Carrier concentration	$2 - 8 \cdot 10^{17} \text{ cm}^{-3}$	$4 - 6 \cdot 10^{16} \text{ cm}^{-3}$
EPD	$< 3 \cdot 10^5 \text{ cm}^{-2}$	$< 3 \cdot 10^5 \text{ cm}^{-2}$
Resistivity range	$\sim 0.03 \ \Omega \cdot \text{cm}$	$\sim 0.3 \ \Omega \cdot \text{cm}$
Density	4.13 g.cm ⁻³	
Melting point	1480°C	
Thermal expansion	$5.3 \cdot 10^{-6} \text{ K}^{-1}$	
Band gap	2.26 eV	
Thermal conductivity	1.1 W.cm ⁻¹ .K ⁻¹ at 300 K	

Gd₃Ga₅O₁₂ GADOLINIUM GALLIUM GARNET (GGG) SUBSTRATE

STANDARD SPECIFICATIONS

CRYSTAL GROWTH	
Growth method	Czochralski (CZ)
Maximum size	Ø 3"
CRYSTALLOGRAPHIC PROPERTIES	
Crystal structure	Cubic a = 1.2382 nm
Color	Pale yellow
PHYSICAL PROPERTIES	
Density	7.02 g.cm ⁻³
Melting point	1730°C
Thermal expansion	$9.7 \cdot 10^{-6} \text{ K}^{-1}$

Ge GERMANIUM SUBSTRATE

APPLICATIONS

- IR optics
- Solar cell application
- Optical fiber production
- Semiconductor and electronics device

STANDARD SPECIFICATIONS

CRYSTAL GROWTH						
Growth method	Czochralski (CZ)					
Maximum size	Ø 3"					
CRYSTALLOGRAPHIC PROPERTIES						
Crystal structure	Cubic a = 0.565 nm					
Dopant available	Antimony (N), Gallium (P)					
Cleavage	<111>					
PHYSICAL PROPERTIES						
Density	5.32 g.cm ⁻³					
Melting point	937°C					
Hardness	6 Mohs					
Thermal expansion	5.75.10 ⁻⁶ K ⁻¹					
PHYSICAL PROPERTIES						
Resistivity range	N-type: < 0.4 Ω.cm P-type: 0.005 - 30 Ω.cm Undoped: > 30 Ω.cm					
Specificity heat capacity	310 J.kg ⁻¹ .K ⁻¹					
Band gap at 273 K	0.67 eV					
Thermal conductivity	58.6 W.m ⁻¹ .K ⁻¹					
Carrier mobility	μ _e = 3900 cm ² .V ⁻¹ .s ⁻¹ μ _h = 1900 cm ² .V ⁻¹ .s ⁻¹					
Conductivity type	P-type or N-type					
CHEMICAL PROPERTIES						
Solubility in water	Insoluble					
Solubility in acids	Soluble in mixture of HCl and HNO ₃ and H ₂ O ₂					
Solubility in organic solvents	Insoluble					
OPTICAL PROPERTIES						
Absorption coefficient	0.02 cm ⁻¹ at 10.6 μm					
Transmission range (thickness 10 mm)	2 to 18 μm					
Refractive index n	2.0 μm	5.0 μm	8.0 μm	10.0 μm	11.0 μm	15.0 μm
	4.1079	4.0153	4.0053	4.0040	4.0031	4.0017

TRANSMISSION SPECTRUM

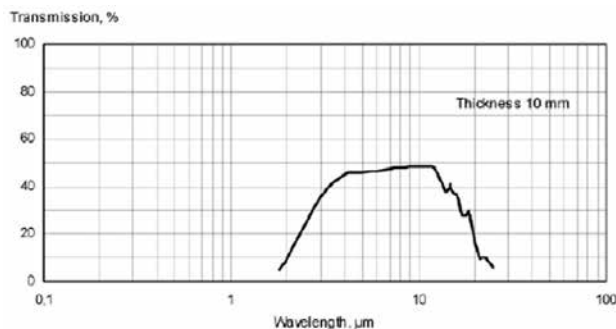

InAs INDIUM ARSENIDE SUBSTRATE

NEYCO provides InAs wafers (Indium Arsenide) to optoelectronics in diameter up to 2 inch. InAs crystal has high uniformity of electrical parameters and low defect density, suitable for MBE or MOCVD epitaxial growth.

STANDARD SPECIFICATIONS

CRYSTAL GROWTH	
Growth method	Czochralski (CZ)
Maximum size	Ø 2"
Standard thickness	500 µm
CRYSTALLOGRAPHIC PROPERTIES	
Crystal structure	Cubic
PHYSICAL PROPERTIES	
Band gap	0.4 eV
Conductivity	Semi-conducting (SI)
Conductivity type	P-type or N-type
Dopant available	Silicon, Zinc

DOPANT AVAILABLE	TYPE	CARRIER CONCENTRATION (cm ⁻³)	MOBILITY (cm ² .V ⁻¹ .s ⁻¹)
Undoped	N	-	> 20000
Si	N	1.10 ¹⁷ - 3.10 ¹⁸ cm ⁻³	10000 - 25000
Zn	P	1.10 ¹⁷ - 5.10 ¹⁸ cm ⁻³	100 - 500

InP INDIUM PHOSPHIDE SUBSTRATE

NEYCO supplies high quality InP single crystal substrates for semiconductor industries. The wafers are cut along precise orientation and highly EPI polished.

APPLICATIONS

InP has been a focus of development since the early 1980s, and today the material is being used as a platform for a wide variety of fiber communications components, including lasers, LEDs, semiconductor optical amplifiers, modulators and photo-detectors.

InP applications for discrete active devices are widespread in communications networking, making it the natural starting place for wholesale integration of passive devices for a complete system on a chip. As a semiconductor material, InP can provide all-in-one integrated functionality that includes light generation, detection, amplification, high-speed modulation and switching, as well as passive splitting, combining and routing. The same material can be used to make high-speed modulators, switches, amplifiers and detectors, or just passive wave guides for interconnecting these diverse devices.

STANDARD SPECIFICATIONS

CRYSTAL GROWTH	
Growth method	Czochralski (CZ)
Standard thickness	500 µm
Maximum size	Ø 2"
CRYSTALLOGRAPHIC PROPERTIES	
Crystal structure	Face-centered cubic (Zinc blende)
PHYSICAL PROPERTIES	
Band gap	1.344 eV
Conductivity	Semi-conducting or semi-insulating (SI)
Conductivity type	P-type or N-type
Dopant available	Silicon, Tin, Zinc, Iron
Density	4.81 g.cm ⁻³
Melting point	1082°C
Thermal conductivity	0.68 W.cm ⁻¹ .K ⁻¹ at 300 K

DOPANT AVAILABLE	TYPE	CARRIER CONCENTRATION (cm ⁻³)	MOBILITY (cm ² .V ⁻¹ .s ⁻¹)	RESISTIVITY (Ω.cm)	EPD (cm ⁻²)
Undoped	N	0.8 - 2.0 .10 ¹⁵	3600 - 4000	0.03 - 0.2	5-6.10 ⁴
Sn, Si	N	0.5 - 1.0 .10 ¹⁸	200 - 2400	0.001 - 0.002	3-5.10 ⁴
		0.5 - 1.0 .10 ¹⁸	1500 - 2000	0.0025 - 0.007	
Zn	P	0.8 - 2.0 .10 ¹⁸	2500 - 3500	0.0025 - 0.006	1-3.10 ⁴
		2.5 - 4.0 .10 ¹⁸	1300 - 1600		
Fe	SI	0.1 - 1.0	2000	10 ⁷ - 10 ⁸	4-5.10 ⁴

LaAlO₃ LANTANUM ALUMINATE SUBSTRATE

LaAlO₃ single crystal provides a good lattice match to many materials with perovskite structure. It is an excellent substrate for epitaxial growth of high T_c superconductors,

magnetic and ferro-electric thin films. The dielectric properties of LaAlO₃ crystal are well suitable for low loss microwave and dielectric resonance applications.

STANDARD SPECIFICATIONS

CRYSTAL GROWTH	
Growth method	Czochralski (CZ)
Max. size	Ø 3"
Standard thickness	0.5 to 1 mm
CRYSTALLOGRAPHIC PROPERTIES	
Crystal structure	Rhombohedral at 25°C a = 0.5357 nm
	Cubic at > 435°C a = 0.379 nm
Twin structure	Twins // to the <100>-planes of the pseudocubic cell
Color	Tan to brown based on annealing condition
PHYSICAL PROPERTIES	
Density	6.52 g.cm ⁻³
Melting point	2180°C
Thermal expansion	9.2.10 ⁻⁶ K ⁻¹
Dielectric constant	24.5
Loss tangent (at 10 GHz)	~ 3.10 ⁻⁴ at 300 K ~ 6.10 ⁻⁵ at 77 K
CHEMICAL PROPERTIES	
Chemical stability	Insoluble in mineral acids at 25°C and soluble in H ₃ PO ₃ at > 150°C

LiAlO₂ LITHIUM ALUMINATE SUBSTRATE

LiAlO₂ is a potential substrate for III-V nitride thin films due to its excellent lattice mismatch to GaN (<0.2% at <100>), chemical stability at high temperature and cost effective.

STANDARD SPECIFICATIONS

CRYSTAL GROWTH	
Growth method	Czochralski (CZ)
Maximum size	Ø 2"
CRYSTALLOGRAPHIC PROPERTIES	
Crystal structure	Tetragonal a = 0.517 nm c = 0.626 nm
Color	Transparent
PHYSICAL PROPERTIES	
Density	2.2 g.cm ⁻³
Melting point	1900°C
Hardness	7.5 Mohs

LiF LITHIUM FLUORIDE SUBSTRATE

APPLICATION

UV window and prism, without deliquescence.

STANDARD SPECIFICATIONS

CRYSTAL GROWTH	
Growth method	Stockbarger technique
Maximum size	Ø 150 mm
CRYSTALLOGRAPHIC PROPERTIES	
Crystal structure	Cubic a = 0.4026 nm
Cleavage plane	<100>
PHYSICAL PROPERTIES	
Density	2.60 g.cm ⁻³
Melting point	870°C

PHYSICAL PROPERTIES						
Hardness	4 Mohs					
Thermal expansion	28.1 - 34.8.10 ⁻⁶ K ⁻¹					
Thermal conductivity	14.2 W.m ⁻¹ .K ⁻¹					
Specific heat capacity	1562 J.kg ⁻¹ .K ⁻¹					
CHEMICAL PROPERTIES						
Solubility in water	0.27 g/100 cm ³					
Solubility in acids	Soluble					
Solubility in organic solvents	Insoluble in acetone and ethylalcohol					
OPTICAL PROPERTIES						
Absorption coefficient	0.05 cm ⁻¹ at 0.2 μm 0.02 cm ⁻¹ at 0.4 μm 0.03 cm ⁻¹ at 2.6-2.9 μm					
Transmission range (thickness 10 mm)	0.12 - 6.5 μm					
Refractive index n	0.2 μm	0.5 μm	1.0 μm	3.0 μm	5.0 μm	6.0 μm
	1.4390	1.3943	1.3871	1.3666	1.3266	1.2975

TRANSMISSION SPECTRUM

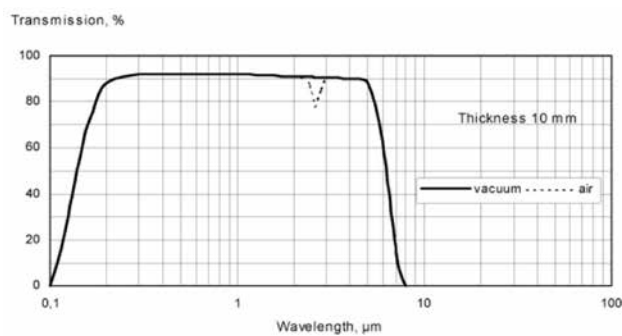

LiGaO₂ LITHIUM GALLATE SUBSTRATE

LiGaO₂ single crystal was grown in 1960's for laser application. However, it is found out that LiGaO₂ is a potential substrate for III-V nitride thin films due to its excellent lattice mismatch to GaN (<0.2%), chemical stability at high temperature and cost effective.

STANDARD SPECIFICATIONS

CRYSTAL GROWTH	
Growth method	Czochralski (CZ)
Maximum size	Ø 20 mm
CRYSTALLOGRAPHIC PROPERTIES	
Crystal structure	Orthorhombic a = 0.54 nm b = 0.6379 nm c = 0.5012 nm
Color	White to brown
Twin structure	No twins and inclusion
PHYSICAL PROPERTIES	
Density	4.18 g.cm ⁻³
Melting Point	1600°C

LiNbO₃ LITHIUM NIOBATE SUBSTRATE

STANDARD SPECIFICATIONS

CRYSTAL GROWTH	
Growth method	Czochralski (CZ)
CRYSTALLOGRAPHIC PROPERTIES	
Crystal structure	Hexagonal a = 0.5148 nm c = 1.3863 nm
PHYSICAL PROPERTIES	
Density	4.64 g.cm ⁻³
Melting point	1250°C
Hardness	5 Mohs
Thermal expansion	Vertical c-axis: 15.4.10 ⁻⁶ K ⁻¹ Parallel c-axis: 7.5.10 ⁻⁶ K ⁻¹

OPTICAL PROPERTIES			
Transmission range	0.4 - 2.90 μm		
Refractive index:	0.633 μm	1.064 μm	1.30 μm
n _o	2.286	2.232	2.220
n _e	2.203	2.156	2.146

TRANSMISSION SPECTRUM

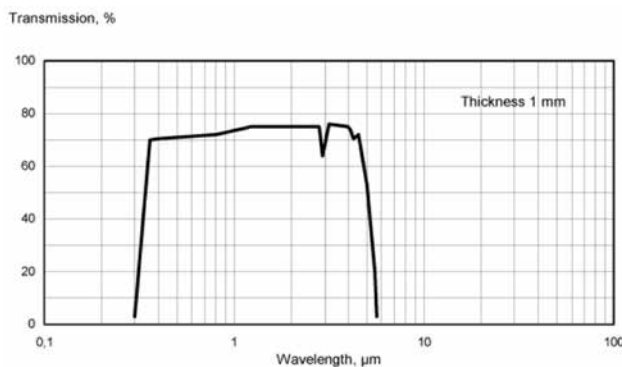

LANTHANUM-STRONTIUM-ALUMINUM-TANTALUM-OXIDE (LSAT) SUBSTRATE

LSAT (LaAlO₃)_{0.3}(Sr₂AlTaO₆)_{0.7} is a newly developing crystal with perovskite structure and twin-free. LSAT has excellent lattice match with high T_c superconductors and many oxide materials. LSAT has lower melting point and can be grown by CZ technology at lower cost, therefore,

it is expected to replace LaAlO₃ and SrTiO₃ as a common single crystal substrate for epitaxial oxide thin films for gain magnetic ferro-electronic and superconductive devices.

STANDARD SPECIFICATIONS

CRYSTAL GROWTH	
Growth method	Czochralski (CZ)
Maximum size	Ø 2"
CRYSTALLOGRAPHIC PROPERTIES	
Crystal structure	Cubic a = 0.7737 nm
Twin structure	No twin and domain visible
Color	Colorless to light brown based on annealing condition
PHYSICAL PROPERTIES	
Density	6.74 g.cm ⁻³
Melting point	1840°C

PHYSICAL PROPERTIES	
Thermal expansion	$10.10^{-6} \text{ K}^{-1}$
Dielectric constant	~ 22
Loss tangent (at 8.8 GHz)	2.10^{-4} at 77 K

MgAl₂O₄ MAGNESIUM ALUMINUM OXIDE SUBSTRATE

MgAl₂O₄ (spinel) single crystals are widely used for bulk acoustic wave and microwave devices and fast IC epitaxial substrates. It is also found that MgAl₂O₄ is a good

substrate for III-V nitrides device. MgAl₂O₄ crystal is very difficult to grow, due to the difficulty in maintaining a single phase structure.

STANDARD SPECIFICATIONS

CRYSTAL GROWTH	
Growth method	Czochralski (CZ)
Maximum size	Ø 30 mm
CRYSTALLOGRAPHIC PROPERTIES	
Crystal structure	Cubic a = 0.8083 nm
Color	Colourless
PHYSICAL PROPERTIES	
Density	3.64 g.cm ⁻³
Melting Point	2130°C
Hardness	8.0 Mohs
Thermal expansion	7.10^{-6} K^{-1}

MgF₂ MAGNESIUM FLUORIDE SUBSTRATE

APPLICATIONS

VUV window and mirror, lens.

STANDARD SPECIFICATIONS

CRYSTAL GROWTH						
Growth method	Stockbarger technique					
Cleavage	<100>, <110>					
Maximum size	Ø 90 mm					
CRYSTALLOGRAPHIC PROPERTIES						
Crystal structure	Tetragonal a = 0.464 nm c = 0.306 nm					
PHYSICAL PROPERTIES						
Density	3.18 g.cm ⁻³					
Melting point	1255°C					
Hardness	6 Mohs					
Thermal expansion	Parallel c-axis: 10.86 - 14.54.10 ⁻⁶ K ⁻¹ Vertical c-axis: 6.23 - 9.25.10 ⁻⁶ K ⁻¹					
Specific heat capacity	920 J.kg ⁻¹ .K ⁻¹					
CHEMICAL PROPERTIES						
Solubility in water	0.0076 g/100 cm ³					
Solubility in acids	Soluble					
Solubility in organic solvents	Insoluble in alcohol					
OPTICAL PROPERTIES						
Absorption coefficient (cm ⁻¹)	0.07 cm ⁻¹ at 0.2 µm 0.02 cm ⁻¹ at 5.0 µm					
Refractive index:	0.2 µm	0.5 µm	1.0 µm	3.0 µm	5.0 µm	7.0 µm
n _o	1.4231	1.3797	1.3736	1.3618	1.3400	1.3044
n _e	1.4367	1.3916	1.3852	1.3724	1.3487	1.3101

TRANSMISSION SPECTRUM

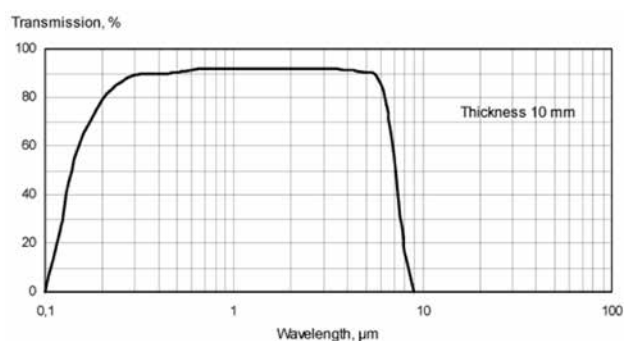

MgO MAGNESIUM OXIDE SUBSTRATE

MgO is an excellent single crystal substrate for thin films of ferro-magnetic, photo-electronic and high Tc superconductor materials.

FEATURES

- Low dielectric loss
- Cleavage plane on the $\langle 100 \rangle$

APPLICATIONS

- High Tc Superconductor
- Electronics and optoelectronics
- Microwave device

STANDARD SPECIFICATIONS

CRYSTAL GROWTH				
Growth method	Flux melt			
Standard thickness	0.5 to 1 mm			
Maximum size	Ø 2"			
CRYSTALLOGRAPHIC PROPERTIES				
Crystal structure	Cubic a = 0.4216 nm			
Cleavage	$\langle 100 \rangle$			
Twin structure	Without twins			
Color	Colorless			
PHYSICAL PROPERTIES				
Density	3.58 g.cm ⁻³			
Melting point	2800°C			
Hardness	5.8 Mohs			
Thermal expansion	8.10 ⁻⁶ K ⁻¹			
Thermal conductivity	40.6 W.m ⁻¹ K ⁻¹			
Specific heat capacity	837 J.kg ⁻¹ .K ⁻¹			
Dielectric constant	8.1			
Loss tangent (at 10 GHz)	~ 9.10 ⁻³ at 77 K			
CHEMICAL PROPERTIES				
Chemical stability	Insoluble in mineral acids at 25 °C and soluble in H ₃ PO ₃ at > 150 °C			
Solubility in water	0.00062 g/100 cm ³			
OPTICAL PROPERTIES				
Transmission range (thickness 1 mm)	0.3 - 7.0 µm			
Refractive index n	0.5 µm	1 µm	3 µm	5 µm
	1.74	1.72	1.68	1.63

TRANSMISSION SPECTRUM

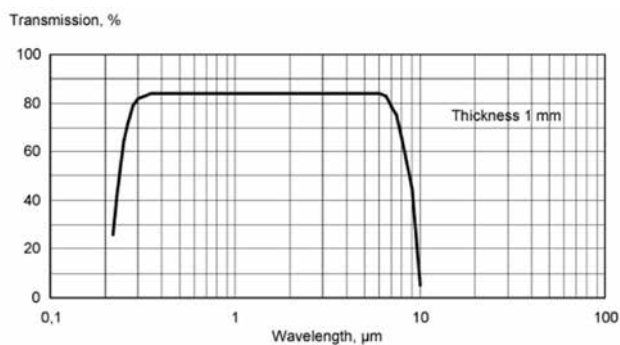

MnO MANGANESE OXIDE SUBSTRATE

STANDARD SPECIFICATIONS

CRYSTAL GROWTH	
Growth method	Verneuil
Maximum size	Ø 15 mm
CRYSTALLOGRAPHIC PROPERTIES	
Crystal structure	Cubic a = 0.4445 nm
Color	Black
PHYSICAL PROPERTIES	
Density	5.4 g.cm ⁻³
Melting point	1650°C
Hardness (Knoop test)	300

NaCl SODIUM CHLORIDE SUBSTRATE

Use only these crystals for fine research work requiring minimum 10 mm square uninterrupted areas.

- Formula: NaCl
- Appearance: Cubic clear (nearly transparent) crystals
- Density: 2.165 g.cm⁻³
- Solubility in water: a thin "wafer" that is 0.05" (1.27 mm) will dissolve in water at room temperature in roughly 30 seconds

GROW EPITAXIAL FILMS

These high quality research grade sodium chloride single crystal substrates offer a major advantage: the ability to grow epitaxial films on a featureless substrate.

The orientation of the film is related to the orientation of the substrate, producing areas of single crystal film.

This feature is ideal for boundary diffusion studies and applications where a single crystal thin film is required. The film is easily removed by floating it off on water or by dissolving away the underlying substrate.

SIZES
25 mm cubes
10 mm cubes
25 mm cubes

Other dimensions upon request.

NdGAO₃ NEODYMIUM GALLATE (NGO) SUBSTRATE

MATERIAL CHARACTERISTICS

- Excellent lattice matches to the typical HTSC composition
- Low dielectric constant and low dielectric loss tangent, which makes it attractive for microwave applications
- Good thermal properties
- No destructive phase transformations

STANDARD SPECIFICATIONS

CRYSTAL GROWTH	
Growth method	Czochralski (CZ)
Maximum size	Ø 2"
Standard thickness	0.5 to 1 mm
CRYSTALLOGRAPHIC PROPERTIES	
Crystal structure	Orthorhombic to > 1000°C a = 0.5426 nm b = 0.5496 nm c = 0.7707 nm Second order phase transformation at 950°C
Twin structure	Without twins
Color	Deep red to green
PHYSICAL PROPERTIES	
Density	7.56 g.cm ⁻³
Melting point	1750°C
Hardness	5.9 Mohs
Thermal expansion	11.10 ⁻⁶ K ⁻¹
Dielectric constant (1 MHz)	20 at 300 K

NiO NICKEL OXIDE SUBSTRATE

STANDARD SPECIFICATIONS

CRYSTAL GROWTH	
Growth method	Verneuil
Maximum size	Ø 15 mm
CRYSTALLOGRAPHIC PROPERTIES	
Crystal structure	Cubic a = 0.419 nm
Color	Black
PHYSICAL PROPERTIES	
Density	6.96 g.cm ⁻³
Melting point	1998°C
Hardness (Knoop test)	560 - 590

SiO₂ QUARTZ SUBSTRATE

FEATURES

- High working temperature
- Good thermal conductivity
- High stability
- High anti corrosion
- Superior mechanical properties
- Stable dielectric constant & low dielectric loss
- High optical transmission

APPLICATIONS

- Photo mask blank
- Sensors
- High frequency circuit (Microwave circuit)
- Biotech arrays
- Laser Optics
- Optical windows and lenses

STANDARD SPECIFICATIONS

CRYSTAL GROWTH	
Growth method	Hydrothermal synthesis
Maximum size	Ø 200 mm
Standard thickness	0.1 mm to 4 mm
CRYSTALLOGRAPHIC PROPERTIES	
Crystal structure	Hexagonal a = 0.490 nm c = 0.539 nm
Color	Colourless
PHYSICAL PROPERTIES	
Density	2.65 g.cm ⁻³
Melting Point	1700°C
Hardness	5.5 - 6.5 Mohs
Thermal expansion	Vertical c-axis: 13.37.10 ⁻⁶ K ⁻¹ Parallel c-axis: 7.97.10 ⁻⁶ K ⁻¹
Resistivity	7.10 ⁷ Ω.cm
Dielectric constant	3.7 - 3.9

SrLaAlO₄ STRONTIUM LANTHANUM ALUMINATE SUBSTRATE

SrLaAlO₄ crystal is a promising substrate material for high T_c superconductor film and other oxide films. It has similar lattice constant to SrTiO₃, but better quality and lower cost because of CZ growth and lower melting point.

APPLICATIONS

High quality YBaCu, BiSrCaCuO, Bi(Pb)CaCuO and TlBaCaCuO thin films have been grown on SrLaAlO₄ substrates by different techniques.

STANDARD SPECIFICATIONS

CRYSTAL GROWTH	
Growth method	Czochralski (CZ)
Maximum size	Ø 18 - 20 mm
Standard thickness	0.5 to 1 mm
CRYSTALLOGRAPHIC PROPERTIES	
Crystal structure	Tetragonal a = 0.3754 nm c = 1.2630 nm
Twin structure	No
Color	Light yellow
PHYSICAL PROPERTIES	
Density	5.924 g.cm ⁻³
Melting point	1650°C
Hardness	7 Mohs
Thermal expansion	Along a-axis: 7.55.10 ⁻⁶ K ⁻¹ Along c-axis: 1.71.10 ⁻⁶ K ⁻¹
Dielectric constant	17
Thermal conductivity	At 12 K: 360 W.m ⁻¹ .K ⁻¹ At 300 K: 8.82 W.m ⁻¹ .K ⁻¹ At 450 K: 7.50 W.m ⁻¹ .K ⁻¹
Dielectric loss tangent (at 10 GHz)	8.10 ⁻⁴ at 77 K
OPTICAL PROPERTIES	
Transmission range	240 to 6670 nm

SrLaGa₃O₇ STRONTIUM LANTHANUM GALLATE SUBSTRATE

STANDARD SPECIFICATIONS

CRYSTAL GROWTH	
Growth method	Czochralski (CZ)
Maximum size	Ø 18 - 20 mm
CRYSTALLOGRAPHIC PROPERTIES	
Crystal structure	Tetragonal a = 0.806 nm c = 0.534 nm

CRYSTALLOGRAPHIC PROPERTIES	
Color	Orange
PHYSICAL PROPERTIES	
Density	5.2 g.cm ⁻³
Melting point	1760°C
Dielectric constant	22
Loss tangent (at 1 MHz)	5.7.10 ⁻⁵ at 300 K

SrLaGaO₄ STRONTIUM LANTHANUM GALLATE SUBSTRATE

APPLICATIONS

High quality YBaCuO, BiSrCaCuO, Bi(Pb)CaCuO and TlBaCaCuO thin films have been grown on SrLaGaO₄ substrates by different techniques.

STANDARD SPECIFICATIONS

CRYSTAL GROWTH	
Growth method	Czochralski (CZ)
Maximum size	Ø 18 - 20 mm
Standard thickness	0.5 to 1 mm
CRYSTALLOGRAPHIC PROPERTIES	
Crystal structure	Tetragonal a = 0.3843 nm c = 1.2680 nm
Twin structure	No
Color	Colorless to yellow
PHYSICAL PROPERTIES	
Density	6.389 g.cm ⁻³
Melting point	1520°C
Thermal expansion	Along a-axis: 10.1.10 ⁻⁶ K ⁻¹ Along c-axis: 1890.10 ⁻⁵ K ⁻¹
Dielectric constant	22
Loss tangent (at 10 GHz)	5.7.10 ⁻³ at 77 K

SrTiO₃ STRONTIUM TITANATE SUBSTRATE

SrTiO₃ single crystal provides a good lattice match to most materials with Perovskite structure. It is an excellent substrate for epitaxial growth of HTS and many

oxide thin films. SrTiO₃ single crystal has also been used widely for special optical windows and as high quality sputtering target.

STANDARD SPECIFICATIONS

CRYSTAL GROWTH	
Growth method	Verneuil
Maximum size	Ø 2"
CRYSTALLOGRAPHIC PROPERTIES	
Crystal structure	Cubic a = 0.3905 nm
Twin structure	Without twins
Color	Colorless to pale yellow
PHYSICAL PROPERTIES	
Density	5.175 g.cm ⁻³
Melting point	2080°C
Hardness	6 Mohs
Thermal expansion	9.10 ⁻⁶ K ⁻¹
Dielectric constant	~ 300
Loss Tangent (at 10 GHz)	2.10 ⁻² at 77 K
CHEMICAL PROPERTIES	
Chemical stability	Insoluble in water

Doped SrTiO₃ is used in the basic research and is applied as conducting material [e.g. back side contacting, application of certain surface sensitive measurements (STM)].

DOPANTS CONCENTRATION AT %	Nb		La	
	AVAILABLE	RESISTIVITY (Ω.cm)	AVAILABLE	RESISTIVITY (Ω.cm)
0.02	X	-	-	-
0.05	X	0.08	X	0.12
0.1	X	0.03	X	-
0.2	X	-	-	-
0.5	X	0.005	X	0.006
1.0	X	0.003	X	-
2.0	X	-	-	-
5.0	-	-	X	0.0007

TiO₂ TITANIUM OXIDE (RUTILE) SUBSTRATE

Rutile (TiO₂) single crystal is one of the most suitable materials for spectral prisms and polarizing devices such as optical isolators and beam displacers because it has a

large birefringence with a high refractive index. Compared to YVO₄, TiO₂ crystal is more stable chemically and physically.

STANDARD SPECIFICATIONS

CRYSTAL GROWTH	
Growth method	Floating zone (FZ)
Maximum size	Ø 1"
CRYSTALLOGRAPHIC PROPERTIES	
Crystal structure	Tetragonal a = 0.459 nm c = 0.296 nm
Color	Pal
PHYSICAL PROPERTIES	
Density	4.26 g.cm ³
Melting point	1825°C
Hardness	7 Mohs
Thermal expansion	Vertical c-axis: 7.2.10 ⁻⁶ K ⁻¹ Parallel c-axis: 9.19.10 ⁻⁶ K ⁻¹
Specific heat capacity	710 J.kg ⁻¹ .K ⁻¹
Thermal conductivity	12.56 W.m ⁻¹ .K ⁻¹
Resistivity	7.10 ⁷ Ω.cm
Dielectric constant	Vertical c-axis: 170 Parallel c-axis: 88
OPTICAL PROPERTIES	
Transmission range (thickness 6 mm)	0.43 - 6.0 μm
Refractive index:	0.6 μm
n _o	2.61
n _e	2.90

TRANSMISSION SPECTRUM

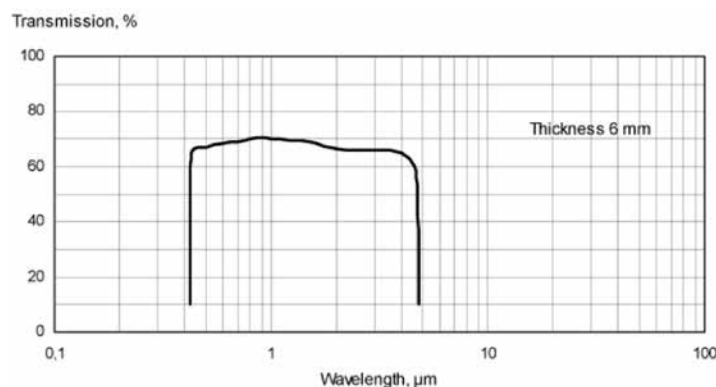

Y₃Al₅O₁₂ YTTRIUM ALUMINIUM GARNET (YAG) SUBSTRATE

STANDARD SPECIFICATIONS

CRYSTAL GROWTH					
Growth method	Czochralski (CZ)				
Maximum size	Ø 2"				
CRYSTALLOGRAPHIC PROPERTIES					
Crystal structure	Cubic a = 1.2005 nm				
Color	Colorless				
PHYSICAL PROPERTIES					
Density	4.55 g.cm ⁻³				
Melting point	1940°C				
Hardness	8.5 Mohs				
Thermal expansion	6.9.10 ⁻⁶ K ⁻¹				
Transmission range (thickness 1 mm)	0.3 - 0.5 µm				
Solubility in water	Insoluble				
Solubility in acids	Unessential				
Refractive index n	0.5 µm	1.0 µm	2.0 µm	3.0 µm	4.0 µm
	1.845	1.8197	1.8035	1.7855	1.7602

TRANSMISSION SPECTRUM

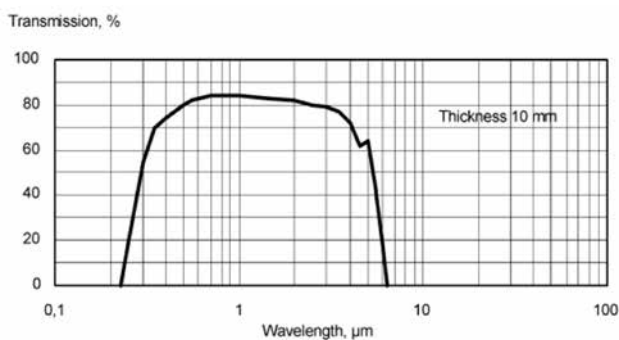

YAlO₃ YTTRIUM ALUMINATE (YAP) SUBSTRATE

STANDARD SPECIFICATIONS

CRYSTAL GROWTH	
Growth method	Czochralski (CZ)
Maximum size	Ø 1.5"
CRYSTALLOGRAPHIC PROPERTIES	
Crystal structure	Orthorhombic a = 0.517 nm b = 0.5307 nm c = 0.7355 nm
Twin structure	No
Color	Colorless
PHYSICAL PROPERTIES	
Density	4.88 g.cm ⁻³
Melting point	1870°C
Thermal expansion	2 - 10.10 ⁻⁶ K ⁻¹
Dielectric constant	16 - 20

YTTRIA STABILIZED ZIRCONIA (YSZ) SUBSTRATE

STANDARD SPECIFICATIONS

CRYSTAL GROWTH	
Growth method	Skull melting (ZrO ₂ /Y ₂ O ₃ 92-8% wt)
Maximum size	Ø 2"
CRYSTALLOGRAPHIC PROPERTIES	
Crystal structure	Cubic a = 0.5125 nm
Color	Colourless
PHYSICAL PROPERTIES	
Density	5.92 g.cm ⁻³
Melting point	2780°C
Hardness	7.5 - 8 Mohs
Thermal expansion	8.10 ⁻⁶ K ⁻¹
Dielectric constant	27
Thermal conductivity	31.8 W.m ⁻¹ .K ⁻¹
CHEMICAL PROPERTIES	
Solubility in water (g/100 cm ³)	Not declare
Solubility in acids	Not declare
Solubility in organic solvents	Not declare

OPTICAL PROPERTIES	
Refractive index n	4 μm
	2.24

TRANSMISSION SPECTRUM

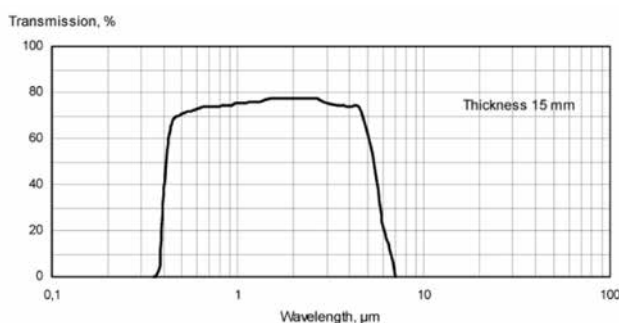

ZnO ZINC OXIDE SUBSTRATE

STANDARD SPECIFICATIONS

CRYSTAL GROWTH	
Growth method	Hydrothermal, seeded vapor phase growth
Maximum size	Ø 35 mm
CRYSTALLOGRAPHIC PROPERTIES	
Crystal structure	Hexagonal a = 0.3252 nm c = 0.5213 nm
PHYSICAL PROPERTIES	
Density	5.7 g.cm ⁻³
Melting point	1975°C
Hardness	4 Mohs
Thermal expansion	3.16.10 ⁻⁶ K ⁻¹
Resistivity range	> 10 ² - 10 ⁴ Ω.cm
Band gap at 300 K	3.2 eV
Thermal conductivity	2.5 W.m ⁻¹ .K ⁻¹
Conductivity type	N-type
Carrier concentration	10 ¹⁰ to 10 ¹⁸ cm ⁻³
Dielectric constant	8.5
OPTICAL PROPERTIES	
Refractive index n	n _o = 2.026, n _e = 2.041

ZnS ZINC SULFIDE SUBSTRATE

STANDARD SPECIFICATIONS

CRYSTAL GROWTH						
Growth method	Seeded vapour phase growth					
Maximum size	Ø 40 mm					
CRYSTALLOGRAPHIC PROPERTIES						
Crystal structure	Cubic a = 0.5411 nm					
PHYSICAL PROPERTIES						
Density	4.09 g.cm ⁻³					
Melting point	1830°C					
Hardness	3 Mohs					
Thermal expansion	7.9.10 ⁻⁶ K ⁻¹					
Resistivity range	> 10 ² -10 ⁴ Ω.cm					
Band Gap (at 300 K)	3.66 eV					
Thermal conductivity	1.73 W m ⁻¹ .K ⁻¹					
Conductivity type	N-type					
Carrier concentration	10 ⁵ to 10 ¹⁶ cm ⁻³					
Dielectric constant	9.67					
	5.13					
Specific heat capacity	530 J.kg ⁻¹ .K ⁻¹					
CHEMICAL PROPERTIES						
Solubility in water	Insoluble					
Solubility in acids	Unessential					
Solubility in organic solvents	Insoluble					
OPTICAL PROPERTIES						
Absorption coefficient	0.001 cm ⁻¹ at 2.7 µm					
	0.2 cm ⁻¹ at 10 µm					
Transmission range (thickness 10 mm)	0.4 - 12.5 µm					
Refractive index n	0.5 µm	0.7 µm	1.0 µm	10.0 µm	11.0 µm	12.0 µm
	2.419	2.332	2.292	2.201	2.186	2.161

TRANSMISSION SPECTRUM

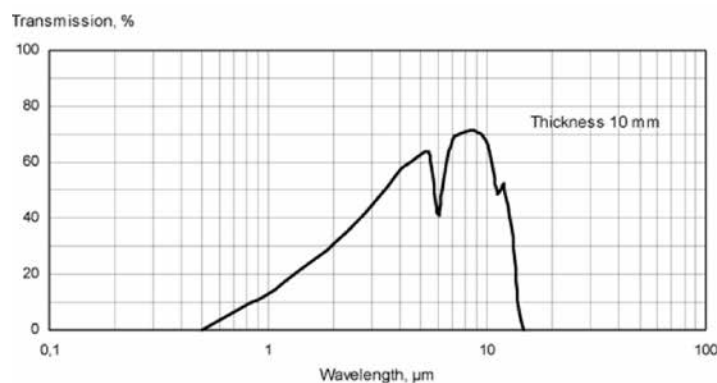

ZnSe ZINC SELENIDE SUBSTRATE

STANDARD SPECIFICATIONS

CRYSTAL GROWTH						
Growth method	Seeded vapour phase growth					
Maximum size	Ø 40 mm					
CRYSTALLOGRAPHIC PROPERTIES						
Crystal structure	Cubic a = 0.5668 nm					
Cleavage	<110>					
PHYSICAL PROPERTIES						
Density	5.26 g.cm ⁻³					
Melting point	1520°C					
Hardness	4 Mohs					
Thermal expansion	7.6.10 ⁻⁶ K ⁻¹					
Thermal conductivity	12.97 W.m ⁻¹ .K ⁻¹					
Specific heat capacity	355 J.kg ⁻¹ .K ⁻¹					
Resistivity range	> 10 ⁸ Ω.cm					
Band Gap (at 300 K)	3.66 eV					
Conductivity type	N-type					
Carrier concentration	10 ⁵ to 10 ¹⁷ cm ⁻³					
CHEMICAL PROPERTIES						
Solubility in water	Insoluble					
Solubility in acids	Soluble					
Solubility in organic solvents	Insoluble					
OPTICAL PROPERTIES						
Absorption coefficient	0.005 cm ⁻¹ at 10.6 μm					
Transmission range (thickness 10mm)	0.55 - 18.0 μm					
Refractive index n	1.0 μm	3.0 μm	5.0 μm	10.0 μm	12.0 μm	15.0 μm
	2.4894	2.4376	2.4296	2.4067	2.3936	2.3662

TRANSMISSION SPECTRUM

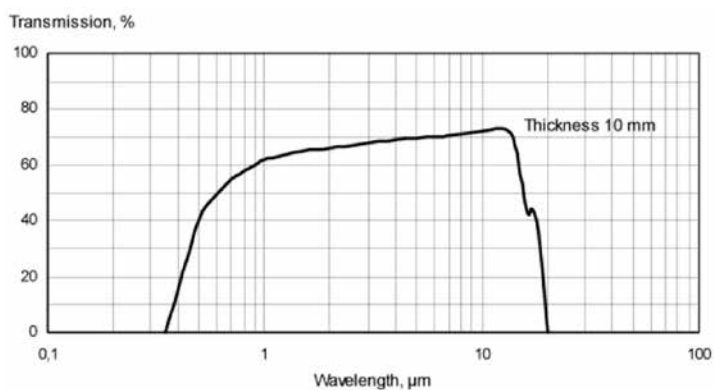

ZnTe ZINC TELLURIDE SUBSTRATE

STANDARD SPECIFICATIONS

CRYSTAL GROWTH	
Growth method	Seeded vapour phase growth
Maximum size	Ø 40 mm
CRYSTALLOGRAPHIC PROPERTIES	
Crystal structure	Cubic a = 0.6089 nm
PHYSICAL PROPERTIES	
Density	5.636 g.cm ⁻³
Melting point	1290°C
Hardness	4 Mohs
Thermal expansion	8.36.10 ⁻⁶ K ⁻¹
Resistivity range	> 10 ⁵ Ω.cm
Band gap (at 300 K)	2.28 eV
Thermal conductivity	12.39 W.m ⁻¹ .K ⁻¹
Conductivity type	P-type
Carrier concentration	10 ¹⁰ to 10 ¹⁷ cm ⁻³
Dielectric constant	8.1
	7.28
OPTICAL PROPERTIES	
Refractive index n	2.68

Glass & Fused Quartz Substrates

BOROSILICATE GLASS

Borosilicate glass, known under trade names such as Pyrex® and Duran®, is widely used in chemical and engineering applications.

This glass is chemically resistant, has a low thermal expansion coefficient and can be used at relatively high temperatures. Our high quality borosilicate glass substrates are optically polished on both surfaces. The excellent

flatness and a low warp of our borosilicate wafers and the thermal coefficient of expansion close to the one of silicon, facilitate sophisticated applications in the semiconductor industry such as anodic bonding to silicon and various micro optical applications.

On request, our borosilicate glass wafers can be made with a ground SEMI standard flat or a notch.

Many types of glass are available :

Borofloat 33, D263T, pyrex, Bk7, B270, Eagle X,...

APPLICATIONS

- Semiconductor applications
- Micro lithography
- Substrates for anodic bonding
- Optical substrates
- Micro system technology
- Micro mechanics
- Microstructure applications

STANDARD SPECIFICATIONS (Borofloat)

GENERAL PROPERTIES	
Density	2.23 g.cm ⁻³
MECHANICAL PROPERTIES	
Young's modulus	64 GPa
Hardness (Knoop test)	480

THERMAL PROPERTIES	
Max. use temperature	up to 500°C
Thermal conductivity	1.14 W.m ⁻¹ .K ⁻¹
Coefficient of linear expansion	3.3.10 ⁻⁶ K ⁻¹
ELECTRICAL PROPERTIES	
Volume resistance	10 ¹⁵ Ω.cm
Dielectric constant	4.6 (20°C, 1 MHz)
Dielectric strength	30 kV.mm ⁻¹
OPTICAL PROPERTIES	
Refractive index n	1.474 at 588 nm (BOROFLOAT 33) 1.52 at 588 nm (B270 CLEAR)

AVAILABLE THICKNESS

From 0.3 mm to 25.4 mm.

TRANSMISSION SPECTRUM

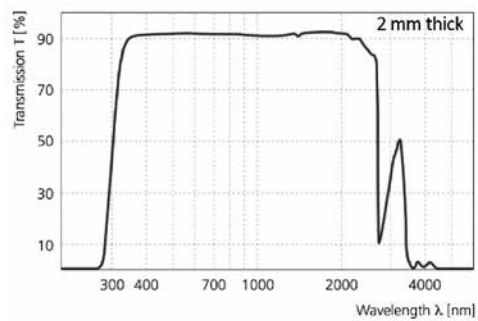

ITO-COATINGS ON GLASS SUBSTRATE

Whenever an electrically conductive surface that also offers a high optical transparency is required, ITO-coating glass series are used. ITO-coating glass is achieved by sputter-coating a thin conductive layer of Indium-Tin-Oxide onto high quality glass substrates.

Because of the low electrical sheet resistances we have available, our ITO-coatings have often be used to shield electromagnetic fields while still transmitting most of the visible light.

APPLICATIONS

- Display technology
- Transparent ITO electrode
- ITO coated microscope slide
- Circuit substrate
- Micro structuring application
- Transparent EMF/EMI/EMC/RFI/HF shielding glass
- Flat antennas for mobile communication
- Conducting glass
- De-Icing applications
- Heatable ITO slide & cover slip

REFRACTIVE INDEX

We present the refractive index data for the ITO coating. It is the refractive index value used for calculating our ITO film performances. Remember that the ITO coatings made are sputtered and therefore are denser than coatings made by vacuum evaporation.

Our series of conductive transparent oxide coatings feature a SiO₂ passivation layer. This quartz barrier layer is only a few nanometers thick, and is located between the substrate and the ITO-coating. This offers an increased electrical insulation performance and minimizes possible leaching of alkali-oxides from the glass into liquid crystals. The process of coating this SiO₂ passivation layer between the ITO thin film coating and the glass substrate, is advantageous for most electronic applications and is efficiently integrated into the production process.

SPECIAL PROPERTIES

- Electrically conductive and optically transparent
- High VIS-NIR light transmission
- High quality glass substrate
- SiO₂ barrier layer
- Low roughness
- High sheet resistance homogeneity
- Uniform transmission homogeneity
- Reflecting in the infrared range

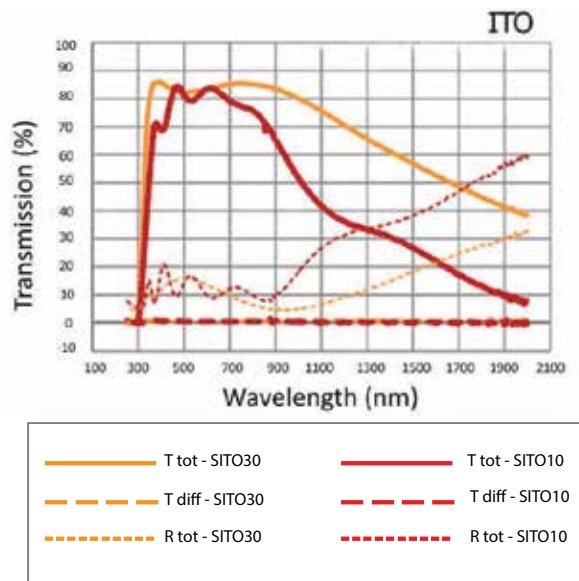

WAVELENGTH (nm)	REFRACTIVE INDEX	EXTINCTION COEFFICIENT
400	2.15	0.025
425	2.1	0.018
450	2	0.01
506	2	0.0087
600	2	0.0065
650	2	0.0044
700	2	0.0042
750	2	0.0042
800	2	0.004
1065	2	0.004

RESISTIVITY RANGE

Resistivity range: 10-15, 15-30, 30-60, 70-100 Ω .cm according ITO thickness.

QUARTZ/FUSED SILICA SUBSTRATE

Quartz glass is an extremely versatile material used in a range of different applications. It has outstanding thermal properties, excellent optical transmission, with good electrical and corrosion performance.

There are two basic ways of making quartz / silica glass:

- By melting silica grains either by gas or electrical heating (the type of heating affects some optical properties). This material can be transparent or, for some applications, opaque.
- By synthesising the glass from chemicals.

This synthetic material, normally referred to as synthetic fused silica, has better optical properties and is somewhat more expensive than the other type.

- Typical index homogeneity: $< 8 \times 10^{-6}$
- Thermal expansion coefficient: $0.58 \times 10^{-6} / K$ (0° to 200°)
- Density: 2.201 g/cm^3

There are mainly three types of fused silica, NEGS1, NEGS2, NEGS3, they are used for different applications. Please refer to below for details.

NEGS1 is mainly used for optics operating in the UV and the visible wavelength range. It is free of bubbles and inclusions. It is equivalent to Suprasil 1&2 and Corning 7980.

NEGS2 is mainly used as mirror substrate, as it has tiny bubbles inside. It is equivalent to Homosil 1, 2&3.

NEGS3 is transparent in the UV, visible and IR spectral regions, but it has many bubbles inside. It is equivalent to Suprasil 300.

PROPERTIES			
	NEGS1	NEGS2	NEGS3
Maximum size	< ø200 mm	< ø300 mm	< ø200 mm
Transmission range (medium transmission ratio)	0.17 ~ 2.10 µm (Tavg>90%)	0.26 ~ 2.10 µm (Tavg>85%)	0.185~3.50 µm (Tavg>85%)
OH-Content	1200 ppm	150 ppm	5 ppm
Fluorescence (EX 254 nm)	Vitually free	Strong V-B	Strong V-B
Impurity Content	5 ppm	20-40 ppm	40-50 ppm
Birefringence constant	2-4 nm/cm	4-6 nm/cm	4-10 nm/cm
Melting Method	Synthetic CVD	Oxy-hydrogen melting	Electrical melting
Applications	Laser substrate: Window, lens, prism, mirror....	Semiconductor and high temperature	IR & UV substrate

PROPERTIES	
Hardness	5.5 - 6.5 Mohs' Scale 570 KHN 100
Design tensile strength	4.8.10 ⁷ Pa (N.mm ⁻²) (7000 psi)
Design compressive strength	Greater than 1.1.10 ⁹ Pa (160,000 psi)
Bulk modulus	3.7.10 ¹⁰ Pa (5.3.10 ⁶ psi)
Rigidity modulus	3.1.10 ¹⁰ Pa (4.5.10 ⁶ psi)
Young's modulus	7.2.10 ¹⁰ Pa (10.5.10 ⁶ psi)
Poisson's ratio	0.17
Coefficient of thermal expansion	5.5.10 ⁻⁷ K ⁻¹ (20°C-320°C)
Thermal conductivity	1.4 W.m ⁻¹ .K ⁻¹
Specific heat	670 J.kg ⁻¹ .K ⁻¹
Softening point	1683°C
Annealing point	1215°C
Strain point	1120°C
Electrical receptivity	7.10 ⁷ Ω.cm (350°C)
Dielectric properties (20°C and 1 MHz)	3.75
Constant	5.10 ⁷ V.m ⁻¹
Strength loss	Less than 4.10 ⁻⁴
Factor dissipation	Less than 1.10 ⁻⁴
Velocity of sound-shear wave	3.75.10 ³ m.s ⁻¹
Velocity of sound/compression Wave	5.90.10 ³ m.s ⁻¹
Chemical Stability (except hydrofluoric)	High resistance to water and acids

TRANSMISSION SPECTRUM

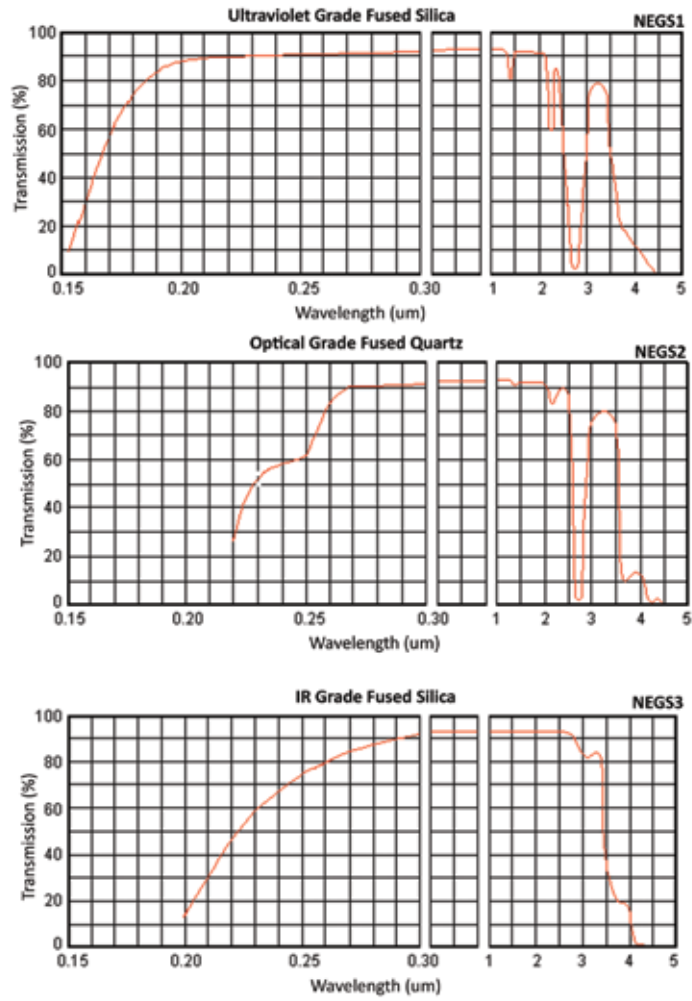

Ceramic Substrates

ALUMINA Al_2O_3 SUBSTRATE (MICROPOLISHED)

Pure alumina ceramic due to their high insulation resistance at elevated temperatures, high dielectric strength, low dielectric loss tangent at high frequencies is one of the best dielectric materials available for use in applications requiring electrical insulation.

The mechanical strength of pure alumina ceramics may be extremely high if properly controlled by the size and homogeneity of the constituent crystallites. It is recommended to use ceramics in compression because

compressive strength is nearly 10 times the one of the flexural strength. This may be achieved through design or by the establishment of operating conditions.

Thermal and chemical properties of pure alumina ceramics are always of great interest. Thermal conductivity is nearly equivalent to stainless steel. Pure alumina ceramics is inert to oxidation, not corroded by chemical agents and not subjected to radiation damage.

APPLICATIONS

- Mechanical seal faces
- Nozzles for abrasives spraying corrosive reagents
- High pressure liquid media
- Laboratory apparatus components
- Metalized parts of high vacuum and high-voltage feed-through, and many other applications

STANDARD SPECIFICATIONS

Purity	99.6%
Color	White
Density	3.8 g.cm ⁻³
Thermal expansion	8.10 ⁻⁶ °C ⁻¹

Thermal conductivity	27 W.m ⁻¹ .K ⁻¹
Dielectric constant (at 1 MHz)	9.8
Surface finish	+/- 25 nm

Glassy Carbon Substrates

Glassy carbon, also called vitreous carbon, is an advanced material of pure carbon combining glassy and ceramic properties with these of graphite's one. Unlike graphite,

glassy carbon has a fullerene-related microstructure. This leads to a great variety of unique material properties.

SPECIAL PROPERTIES

- High temperature resistance in inert gas or vacuum up to 3000°C
- High purity
- Extreme corrosion resistance
- Impermeability to gas and liquids, no open porosity
- No wetting by melts
- High hardness and strength
- Low density
- High surface quality, no particle generation
- Low thermal expansion
- Extreme resistance to thermal shock
- Isotropy of physical and chemical properties
- Good electrical conductivity
- Biocompatibility

STANDARD SPECIFICATIONS

	PLATES	PLATES / FILMS
Maximum service temperature (vacuum or inert gas)	3000°C	1000°C
Density	1.42 g.cm ⁻³	1.54 g.cm ⁻³
Open porosity	0%	0%
Permeability coefficient	10 ⁻⁹ cm ² .s ⁻¹	10 ⁻¹¹ cm ² .s ⁻¹
Vickers hardness	230 HV1	340 HV1
Flexural strength (4 point)	260 N.mm ⁻²	210 N.mm ⁻²
Young's modulus	35 kN.mm ⁻²	35 kN.mm ⁻²
Compressive strength	480 N.mm ⁻²	580 N.mm ⁻²
Specific electrical resistance (RT)	45 Ω.µm	50 Ω.µm
Thermal conductivity (RT)	6.3 J.K ⁻¹ .m ⁻¹ .s ⁻¹	4.6 J.K ⁻¹ .m ⁻¹ .s ⁻¹
Median linear coefficient of expansion (20-200°C)	2.6.10 ⁻⁶ K ⁻¹	3.5.10 ⁻⁶ K ⁻¹

AVAILABLE DIMENSIONS (Examples)

	THICKNESS	DIMENSIONS
PLATES	0.3 mm 0.5 mm	25 x 25 mm 50 x 50 mm 100 x 100 mm
	1 to 6 mm	25 x 25 mm 50 x 50 mm 100 x 100 mm 200 x 200 mm
FILMS	60 µm 100 µm 140 µm 180 µm	25 x 25 mm 50 x 50 mm 100 x 100 mm

Other dimensions and custom made parts are available on request.

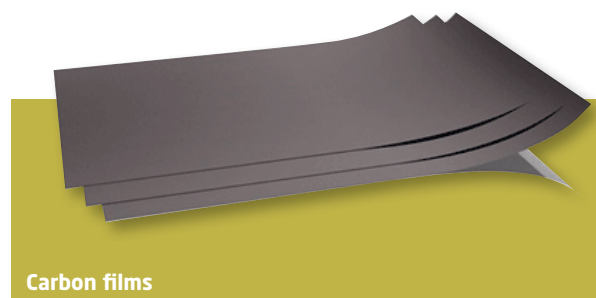
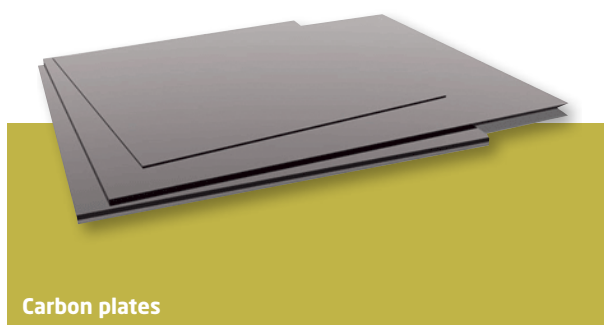

Please ask for your exact dimensions.

HOPG & Mica Substrates

HIGHLY ORDERED PYROLYTIC GRAPHITE HOPG

HOPG, is a relatively new form of high purity carbon and provides microscopists with a renewable and smooth surface. Unlike mica, HOPG is completely non-polar, and for samples where elemental analysis will also be done, it provides a background with only carbon in the elemental signature. The extreme smoothness of HOPG gives results in a featureless background, except at atomic levels of resolution.

The structure is strictly columnar, which means, the columns run vertically within the flat slab of the material. The grain boundaries can be seen on the lateral surfaces. The mosaic spread is the angle of deviation of the grain's boundary from this perpendicular axis (of the columnar structure).

USE AT ELEVATED TEMPERATURES

As more and more applications are found for HOPG in research and technology, more and more applications are requiring good high temperature characteristics. We can report the following information which should be useful for those contemplating such usage:

- Air: 500°C (Starts to burn)
- Vacuum at 10^{-1} mbar range 2500°C
- Inert atmosphere (N₂, Ar, He): 3500°C

DENSITY OF HOPG

The density for all three grades (ZYA, ZYB, and ZYH) is 2.27 g.cm⁻³.

GRADE ZYA

Comparable to the very best "calibration grade" HOPG and exhibiting a 0.4° +/- 0.1°. This is the most highly ordered, lateral grain size is typically up to about 3 mm but can be as large as 10 mm, and is used primarily for instrument calibration purposes or for research experiments where for some reason, the very ultimate in HOPG order is needed.

GRADE ZYB

This grade exhibits a mosaic angle as small as 0.8° +/- 0.2°. This grade is slightly less highly ordered than ZYA but is acceptable for most users. The lateral grain size can be up to 0.5 mm but can be as large as 1 mm.

GRADE ZYH

Exhibits a mosaic angle as small as $3.5^\circ \pm 1.5^\circ$. This grade is much less highly ordered and has a grain size not larger than the range of 30-40 nm.

HOPG is available in :

- Squares & rectangles
- Discs

MICA SHEETS AND SUBSTRATES

APPLICATIONS

For AFM studies, and for those making either carbon films or doing thin film coating research and wanting a higher quality mica as defined as having fewer "steps" on a freshly cleaved surface, we would recommend grade V-4. This grade is also great for use with AFM where a polar substrate is desired or where polarity of the substrate does not matter.

For AFM calibration studies or perhaps the ultimate substrate for carbon film production, we offer the grade V-1.

Mica can also be used as a substrate for binding cells to be characterized by TEM.

Mica are available in :

- Squares & rectangles
- Discs

- Chemical Formula: $K_2OAl_2O_3SiO_2$
- Appearance: Semi clear to gray translucent sheets, strips, and discs
- Specific gravity: 2.7 g.cm^{-3}
- Hardness on Mohs scale of hardness: 2 - 2.25
- Grade V-1 Muscovite: Highest possible quality
- Grade V-4 Muscovite: Premium research quality
- Grade V-5 Muscovite: Research quality

Wafer Tweezers

We offer a selection 18 different tweezers styles dedicated to delicate substrates.

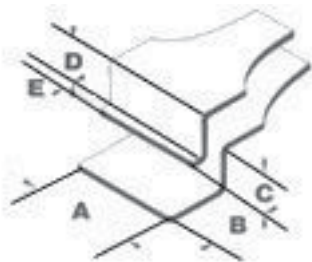

STYLE	DIMENSIONS (in mm)				
	A	B	C	D	E
Style #2W	6.5	5	2.5	4	-
Style 2WF	6.5	9	2.5	4	2.5
Style 2WFG	6.5	9	2.5	4	2.5
Style 3W	9.5	10	2.5	4	-
Style 3WF	9.5	10	2.5	4	2.5
Style 3WFG	9.5	10	2.5	4	2.5
Style 4W	12	9	2.5	4	-
Style 4WF	12	9	2.5	4	2.5
Style 4WFG	12	9	2.5	4	2.5

	STYLE	DESCRIPTION	P/N
	Style #2W Length: 120 mm	Antimagnetic Stainless Steel	OS2W0-XD
		PTFE Coated Antimagnetic Stainless Steel	S2W0T-XD
	Style 2WF Length: 119 mm	Antimagnetic Stainless Steel	OS2WF-XD
		PTFE Coated Antimagnetic Stainless Steel	S2WFT-XD
	Style 2WFG Length: 120 mm	Antimagnetic Stainless Steel	S2WFG-XD
		PTFE Coated Antimagnetic Stainless Steel	S2WFGT-XD
	Style 3W Length: 125 mm	Antimagnetic Stainless Steel	OS3W0-XD
		PTFE Coated Antimagnetic Stainless Steel	S3W0T-XD
	Style 3WF Length: 125 mm	Antimagnetic Stainless Steel	OS3WF-XD
		PTFE Coated Antimagnetic Stainless Steel	S3WFT-XD
	Style 3WFG Length: 125 mm	Antimagnetic Stainless Steel	S3WFG-XD
		PTFE Coated Antimagnetic Stainless Steel	S3WFGT-XD
	Style 4W Length: 133 mm	Antimagnetic Stainless Steel	OS04W-XD
		PTFE Coated Antimagnetic Stainless Steel	S04WT-XD
	Style 4WF Length: 133 mm	Antimagnetic Stainless Steel	OS4WF-XD
		PTFE Coated Antimagnetic Stainless Steel	S4WFT-XD
	Style 4WFG Length: 125 mm	Antimagnetic Stainless Steel	S4WFG-XD
		PTFE Coated Antimagnetic Stainless Steel	S4WFGT-XD
	Style 33A Length: 112 mm Width at end: 6.5 mm	Antimagnetic Stainless Steel	OS33A-XD
		PTFE Coated Antimagnetic Stainless Steel	S33AT-XD
	Style 34A Length: 127 mm Width at end: 6.2 mm	Antimagnetic Stainless Steel	OS34A-XD
		PTFE Coated Antimagnetic Stainless Steel	S34AT-XD

	STYLE	DESCRIPTION	P/N
	Style 35A Length: 121 mm Width at end: 6.5 mm	Antimagnetic Stainless Steel	0S35A-XD
		PTFE Coated Antimagnetic Stainless Steel	S35AT-XD
	Style 36A Length: 124 mm Width at end: 6.2 mm	Antimagnetic Stainless Steel	0S36A-XD
		PTFE Coated Antimagnetic Stainless Steel	S36AT-XD
	Style 37S Length: 124 mm Width at end: 6.5 mm	Antimagnetic Stainless Steel	0S37S-XD
		PTFE Coated Antimagnetic Stainless Steel	S37ST-XD
	Style 84A Length (Total): 121 mm Width of pick up: 2 mm Length of top pick up: Top: 5 mm Bottom: 6 mm	Antimagnetic Stainless Steel	0S84A-XD
		PTFE Coated Antimagnetic Stainless Steel	S84AT-XD
	Style 85C Length: 121 mm Width at end: 7.0 mm	Antimagnetic Stainless Steel	0S85C-XD
		PTFE Coated Antimagnetic Stainless Steel	S85CT-XD
	Style 86B Length: 121 mm Width at end: 2.7 mm	Antimagnetic Stainless Steel	0S86B-XD

 See Section L - Sample Preparation in this catalogue for other tweezers.

Vacuum Pen Dedicated to Fragile Substrates

Our vacuum pen allows to move substrates safely & easily. Vacuum is generated by pressing a releasing push bar. The pen body is made of aluminum & static dissipative materials. Recommended temperature operating range: +20 to +40°C



Thermo Patch - Vacuum Environment

This product is label type temperature indicator able to use under primary vacuum environment. Temperature monitoring can be done without wiring and electric powers supply just by applying this label on where it is necessary. Color-changing area changes its color from light yellow to black when response temperature is exceeded.

This product was designed to minimize precision error under vacuum condition. Moreover, low out gassing material is used to reduce out gassing from label.

PRODUCT NUMBER	TEMPERATURE RANGE (°C)	ACCURACY	SIZE (mm) (LxWxH)	PACKAGING
TP-40	40 - 45 - 50	± 2° C	8 x 20 x 0.25	10 units/pack
TP-60	60 - 65 - 70 - 75	± 2° C		
TP-80	80 - 85 - 90	± 2° C		
TP-100	100 - 105 - 110 - 115	± 2° C		
TP-120	120 - 125 - 130 - 135	± 2° C		
TP-140	140 - 150 - 160 - 170	± 4° C		
TP-180	180 - 190 - 200 - 210	± 4° C		

Sample
(VL 100)

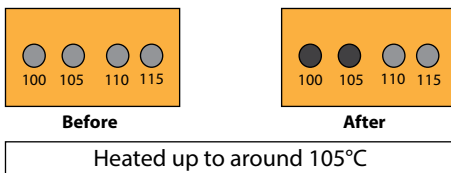



neyco

30 avenue de la Paix
92170 Vanves - France
Tel: +33(0)1 41 90 50 50
Fax: +33(0)1 41 90 50 51

www.neyco.fr



Materials J 2018-1

neyco



MATERIALS WIRES & FOILS

- Metallization Aluminum Wires..... K 02
- Wire Forming for Vacuum Metallization K 03
- Protective Aluminum Rolls..... K 04
- Protective Coating NE-200 K 05
- Wires, Foils & Rods K 06
- Bonding Wires..... K 07

Metallization Aluminum Wires

These pure Aluminum wires are used for metallization process in vacuum-coating equipments.

SPECIFICATIONS

Purity grades: from 99.5% to 99.99%
Wire diameters: from 1.00 mm to 3.00 mm

APPLICATIONS

- Flexible packagings
- Solar films
- Capacitors
- Holograms
- Head lights
- Reflective coatings (various applications)

Each spool is delivered with a specific certificate of analysis, and individually identified which guarantees the total traceability of the material.

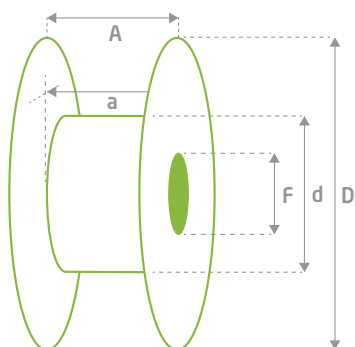

Al wire on plastic spool

ORDERING INFORMATION

P/N (INVENTORY)	DIMENSIONS	PURITY
ALU1.0	Ø 1.0 mm ; 5 kg	99.99%
ALU1.2	Ø 1.2 mm ; 5 kg	99.99%
ALU1.5	Ø 1.5 mm ; 5 kg	99.99%
ALU1.57	Ø 1.57 mm ; 2 kg	99.8%
ALU2.0	Ø 2.00 mm ; 5 kg	99.99%

Other diameters and purities on request.

STANDARD SPOOL DIMENSIONS (mm)

D	d	F	A	a	CAPACITY
200	102	51	53	44	2.2 kg
250	125	18	78	68	5.2 kg

Wire Forming for Vacuum Metallization

Neyco provides Aluminum, Stainless Steel, Nickel/Chromium wire forming and other dedicated shapes for vacuum metallization.

Each lot of product is identified with a dedicated number, which guarantees the total traceability of the material. UHV Cleaning in our laboratory.

Shapes, dimensions and weights: upon request.



Protective Aluminum Rolls

Neyco provides high-quality Aluminum rolls dedicated to vacuum applications (UHV and secondary vacuum compatible).



P/N (INVENTORY)	DIMENSIONS	THICKNESS	PURITY
ROULALU	200 mm x 200 m	11 μm	99.5+%
ROULALU2	500 mm x 200 m	12 μm	99.5+%
ALLU100X30	100 mm x 200 m	30 μm	99.5+%
ROULALU-500x50	500 mm x 50 m	50 μm	99.5+%
ALU120x30	120 mm x 30 m	30 μm	99.5+%
ALU0.1X600X50	600 mm x 50 m	100 μm	99.5+%

Other thickness and dimensions available on request (even in small quantities).

Protective Coating NE-200

NE-200 is a transparent hydrophobic hard coatings (SiO₂ base) liquid precursor.
Other name: Hexamethyldisiloxane, HMDSO, Silicone fluid, colourless.

PHYSICAL AND CHEMICAL PROPERTIES

Formula	O[Si(CH ₃) ₃] ₂
Boiling point	100°C
Melting point	-68°C
Flash point	-6°C
Vapour pressure	42 mbar at 20°C
Specific gravity	0.76 g/cm ³
Viscosity	0.65 cSt at 25°C



PACKAGING

5 liters plastic case (continuous inventory).

K

Wires, Foils & Rods

Neyco provides high purity metals and metal alloys in wires, rods, plates and foils.

SOME EXAMPLES OF MATERIALS

Al, Ag, Au, Cr, Co, Cu, Hf, In, Fe, LaB₆, Mg, Mo, Ni, Nb, Pb, Pt, Pd Ta, Si, Sn, Ti, W, V, Zn, Zr, Stainless Steel 304L/316L/316LN...AlSi...

PURITIES

99.8% to 99.999+%.

DIMENSIONS

- Thickness:
 - from 2 μm to 25 μm for ultrathin foils,
 - few μm to several mm for others.
- Other dimensions:
 - according to request.

All items are delivered with an analysis certificate.



Lanthanum hexaboride, LaB₆ rods



Tungsten foils, W

Bonding Wires

Bonding wires are used for a wide range of products, such as integrated circuits (ICs and LSIs) and transistors. It connects Aluminum electrode and Lead electrode on semiconductor IC chip.

Our bonding wires are delivered with a specific certificate of analysis.

TANAKA ALUMINUM BONDING WIRES

AI BONDING WIRE

Features

- Excellent corrosion resistance under PCT (TANW type)
- Excellent bondability
- Hard, Soft-1, and Soft-2 are available according to applications.

Dimensions

Diameter from 100 ±5 μm to 500 ±10 μm.

Cross section after PCT

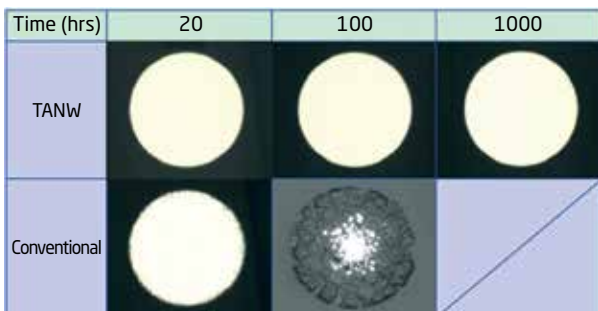

Wire Dia.: 300 μm PCT: at 121°C, 100% RH, 2atm

Al 1%Si BONDING WIRE

Features

- Uniform Si distribution
- Stable mechanical properties
- Stable quality wire without any curl, dirt and surface flaws
- Excellent bondability
- Excellent corrosion resistance under PCT (TABN type)

Dimensions

Diameter from 18 ±1 μm to 80 ±3 μm.

Cross section after PCT

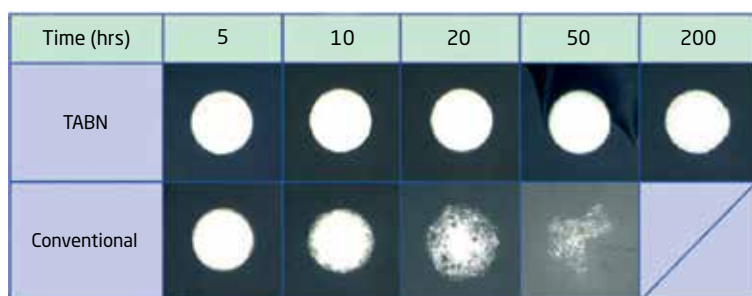

Wire Dia.: 30 μm PCT: at 121°C, 100% RH, 2atm

Al ALLOY BONDING WIRE

Features

- 99% purity Al alloy
- Finer grain size & higher tensile strength
- Excellent heat resistance
- Excellent thermal fatigue resistance

Dimensions

Diameter from 100 μm to 500 μm.

TANAKA GOLD BONDING WIRES

Au BONDING WIRE

Features

- Stable stitch bond (1st and 2nd bondings)
- Excellent performance in thermal stress environment
- Fine pitch bonding
- Excellent bonding
- Good for fine pitch small pads
- High strength with less wire sweep
- Less neck damage, good for fine pitch pads
- Super low loops (long & short)

Dimensions

Diameter from 15 ±1 μm to 38 ±1 μm.



Au ALLOY BONDING WIRE

Features

- Higher bond reliability on halogen compound (GPG series)
- Good squashed ball shape (GPG -2)
- Continuous wire bond stability (GPG-3)

Dimensions

Diameter from 15 μm to 30 μm.

Au BUMPING WIRE

Features

- Small deviation of ball neck height after bumping
- Steady bump shape
- No bond pad damage after bonding (LGBE)
- Low deterioration of shear strength in aging test at 200°C (GBC)

Dimensions

Diameter from 15 μm to 38 μm.

TANAKA SILVER ALLOY BONDING WIRE

Ag ALLOY BONDING WIRE

Features

- Reduce material cost with good bondability
- Lower material costs than Gold wire and higher bondability than Copper wire
- High reflectivity in low wavelength range
- Low resistivity (SEB.SEC type)
- Softer FAB (SEC type)

Dimensions

Diameter from 15 μm to 30 μm .

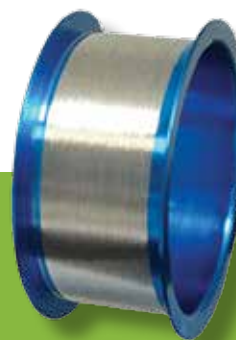

Silver alloy bonding wire spool

TANAKA COPPER BONDING WIRES

Cu BONDING WIRE

Features

- Enables a reduction in costs with a lower material cost than gold bonding wires
- Excellent reliability
- Wide bonding window
- High and stable bondability

Dimensions

Diameter from 15 ± 1 μm to 500 ± 10 μm .

Cu ALLOY BONDING WIRE

Features

- Higher bond reliability
- Wides bonding window
- Lower resistivity
- Softer FAB

Dimensions

Diameter from 18 μm to 25 μm .



neyco

30 avenue de la Paix
92170 Vanves - France
Tel: +33(0)1 41 90 50 50
Fax: +33(0)1 41 90 50 51

www.neyco.fr



Materials K 2018-1

neyco



MATERIALS SAMPLE PREPARATION & CHARACTERISATION

- Conductive Paints L 02
- Conductive Adhesives L 04
- PDMS L 07
- Polyimide Silicone Tape L 10
- High Precision Tweezers L 12
- Grids for SEM & TEM..... L 17
- Tripod® Polisher for Sample Preparation..... L 24
- Crystalbond™ L 25
- Cargille Refractive Index Fluids L 27
- Plasma Matrix Series (2 gas entries)..... L 28
- Small Tools L 29

Conductive Paints

CONDUCTIVE CARBON PAINT

The micrographite particles are uniformly dispersed in isopropanol and air-dry rapidly at room temperature. Although there are some low level impurities, these are generally not seen by most energy dispersive ray spectroscopy (EDS) systems. The Carbon Paint is very easy to use with our exclusive brush-in-cap applicator. The Carbon Paint is formulated with a small amount of a special polymer to give extra adhesive characteristics to the paint. If the Carbon Paint should dry out, it can be resuspended with our Carbon Paint Thinner. The Carbon Paint products has an essentially infinite shelf life and we will guarantee the product's integrity in the unopened state as long as needed for the our customer's use date.

Sheet resistance: 1.2 kΩ/sq (25 μm film thickness).



PRODUCT	PACKAGING	P/N
Conductive Carbon Paint	3/4 fl.oz. (21 ml)	05006-AB
	60 ml	05006-GA
	500 ml	05006-RA
	1 Gallon (3785 ml)	05006-XK
Carbon Paint Thinner	30 ml	05007-DA
	60 ml	05007-AB

CONDUCTIVE SILVER PAINT

The Silver Paint is formulated with a small amount of a special polymer to give the product extra adhesive characteristics, but without degrading the otherwise outstanding out-gassing characteristics.

Sheet resistance: 12 mΩ/sq (25 μm film thickness).

PRODUCT	PACKAGING	P/N
Conductive Silver Paint	0.5 Troy oz. (15.5 g)	05001-AB
	1 Troy oz. (31.1 g)	05002-AB
	60 ml (90.0 g)	05002-GA
Silver Paint Thinner	30 cc	05004-DA
	60 cc	05004-AB
	500 cc	05004-RA

CONDUCTIVE PLATINUM PAINT

The Platinum Paint has been formulated for those applications requiring high temperature performance as well as chemical inertness. When applied on a surface, the thin layer, after firing, takes on the bulk properties of Platinum.

Sheet resistance: 5-10 Ω/sq (25 μm film thickness).

PRODUCT	PACKAGING	P/N
Conductive Platinum Paint	10 g	04990-AB
Platinum Paint Thinner	30 ml	04989-AB

Conductive Adhesives

CONDUCTIVE DOUBLE SIDED ADHESIVE SHEETS

These double sided adhesive, electrically conductive sheets were specially developed for attaching samples to be examined by SEM and/or EDS. Use Silver, for its higher conductivity, for straight SEM work. Use Carbon for EDS work where it is important to eliminate the X-rays from the substrate.

Both Silver and Carbon adhesives have these advantages:

- Enable the mounting of samples without contamination from either Silver Paint or Carbon Paint.
- Enable the mounting of highly porous or other absorbent samples without distortion caused by liquid being pulled into the sample.
- Provide good conductivity.
- These conductive adhesives are both available in sheet form (Ag and C) and roll form (C only). Additionally, the sheets are available as "large sheets" for applications outside the general SEM area.
- UHV "compatible" to the extent that samples can be mounted for examination by Field Emission SEM, FE-SEM and XPS.

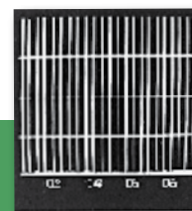

EDS Scan of Carbon Sheets

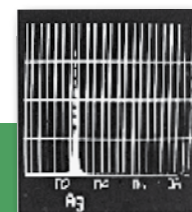

EDS Scan of Silver Sheets

PRODUCT	SIZE & PACKAGING	P/N
Carbon Conductive Double Sided Adhesive Sheets	50 mm x 120 mm, 0.16 mm thick adhesive layer, 10 sheets per pkg	05071-AB
	500 mm x 500 mm, 0.16 mm thick adhesive layer, 1 sheet per pkg	05080A-AB
Silver Conductive Double Sided Adhesive Sheets	50 mm x 120 mm, 0.13 mm thick adhesive layer, 5 sheets per pkg	05070-AB

ADHESIVE TAPES

3M® COPPER CONDUCTING TAPES

These fine tapes consist of a specially developed conductive adhesive, applied to high purity, thin Copper foil for fastening samples of varying shapes and sizes to SEM mounts.

These tapes are available in two forms, single sided adhesive and double sided adhesive and in addition, are also available in a nice variety of different widths for different size SEM mounts.

CONDUCTIVE DOUBLE SIDED CARBON ADHESIVE TAPE

These double sided adhesive, electrically conductive tapes were specially developed to attach samples to be examined by SEM and/or EDS. A conductive Carbon based product is recommended for EDS work where it is important to eliminate the rays coming into the detector from the substrate.



ORDERING INFORMATION

PRODUCT	WIDTH mm (inch)	LENGTH (m)	P/N
3M® Copper Conducting Tapes:			
- Single Sided Adhesive Copper Conducting Tape, 3M® Code 1181	6.35 (1/4")	16.45	05012-AB
	12.5 (1/2")	16.45	05012A-AB
	25.4 (1")	16.45	05012B-AB
	50.8 (2")	16.45	05012C-AB
	76.2 (3")	16.45	05012D-AB
	203.2 (8")	16.45	05012E-AB
- Double Sided Adhesive Copper Conducting Tape, 3M® Code 1182	6.35 (1/4")	16.45	05085-AB
	12.5 (1/2")	16.45	05085A-AB
	25.4 (1")	16.45	05085B-AB
	50.8 (2")	16.45	05085C-AB
	76.2 (3")	16.45	05085D-AB
Conductive Double Sided Carbon Adhesive Tape	6	20	05081-AB
	8	20	05072-AB
	12	20	05082-AB
	25	20	05076-AB
	50	20	05083-AB

ADHESIVE DISCS AND TABS

DIE-CUT CARBON CONDUCTIVE DOUBLE SIDED ADHESIVE DISCS

The double sided adhesive Carbon filled conductive discs combine both high purity and an almost coverglass smoothness to the sticky surface. In addition, the die-cut discs bring a high level of convenience to the SEM user who can order discs of the precise size needed for their respective SEM mounts. Furthermore, one will never see a static charge on the discs which makes for easy mounting of dry powders.



Double sided adhesive Carbon discs,
12 mm diameter

DIE-CUT NONCONDUCTIVE DOUBLE SIDED ADHESIVE DISCS

These are specially made double sided adhesive tabs, made from a material ideally suited for the mounting of samples for AFM (atomic force microscopy) and certain specialized SEM studies where a nonconductive substrate is desired.

ORDERING INFORMATION

PRODUCT	Ø OF DISC	# DISCS/PKG	P/N	
Die-Cut Carbon Conductive Double Sided Adhesive Discs - For SEM, ESD, and other analytical applications	9 mm	440	05073-BA	
	12 mm	240	05077-BA	
	25 mm	80	05074-BA	
	- UltraSmooth™ Carbon Discs	9 mm	100	04966-BA
		12 mm	100	04967-BA
		25 mm	54	04968-BA
Die-Cut Nonconductive Double Sided Adhesive Discs	10 mm	2592	05095-AB	

PDMS

Polymethylsiloxane (PDMS) is the most widely used silicon-based organic polymer and is particularly known for its unusual rheological (or flow) properties. It's optically clear, inert, and non-flammable.

PDMS is commonly used as a stamp resin in the procedure of soft lithography making it one of the most common materials used for flow delivery in microfluidics chips.

SOME APPLICATIONS

- Power supplies
- Connectors
- Sensors
- Industrial controls
- Transformers
- Amplifiers
- High voltage resistor packs
- Relays
- Adhesive/Encapsulant for solar cells
- Adhesive handling beam lead integrated circuits during processing
- LED lighting encapsulation

SYLGARD® 184

Sylgard® 184 is a Dow Corning silicone encapsulant, mainly used in electronic applications.

PDMS* provides unparalleled protection for electronic modules and devices ranging from relatively simple to highly complex architectures and geometries. Silicones work as durable dielectric insulation, as barriers against environmental contaminants, and as stress-relieving shock and vibration absorbers over a wide temperature and humidity range.

In addition to sustaining their physical and electrical properties over a broad range of operating conditions, silicones are resistant to ozone and ultraviolet degradation and have good chemical stability.

*Polymethylsiloxane



Sylgard®184

DESCRIPTION & FEATURES

Sylgard® 184 is supplied as two-part liquid component:

- Mix Ratio (by weight or volume): 10:1
- Components (as supplied): Base/Curing agent
- Transparent encapsulant with good flame resistance
- Flowable
- Room temperature or heat cure
- High tensile strength

When liquid components are thoroughly mixed, the mixture cures to a flexible elastomer, which is suited for the protection of electrical/electronic applications. Sylgard 184 cures without exotherm at a constant rate regardless of sectional thickness or degree of confinement. It requires no post cure and can be placed in service immediately following the completion of the cure schedule with an operating temperature range of -45 to 200°C.

TYPICAL PROPERTIES

Color	Clear
Dynamic viscosity (mixed)	3500 mPa.s
Hardness, Durometer	43 Shore A
Specific gravity (cured)	1.03
Working time (25°C)	90 min
Cured time (25°C) (150°C)	48 h 10 min
Refractive Index @ 589 nm	1.4118
Shelf life from date of manufacture (25°C)	24 months

PACKAGING

1.1 kg and 5.5 kg (available on stock) / 22 kg / 224.5 kg.

RTV615

RTV615, is a Momentive silicone rubber compounds used for protection of electronic components and assemblies against shock, vibration, moisture, ozone, dust, chemicals, and other environmental hazards by potting or encapsulation of the components and assemblies.

DESCRIPTION & FEATURES

RTV615 is supplied as two-part liquid components kits with curing agent in matched kits which are designed for use at a convenient 10:1 ratio by weight. This compound is clear and colorless with a low viscosity.

- Mix Ratio: 10:1
- Low viscosity
- Excellent electrical insulation and shock resistance
- Cure rate can be accelerated by heat
- Chemical composition contains no solvents for ease of use on production lines
- Reversion resistance and hydrolytic stability permit use in high humidity environments at elevated temperatures
- Clarity permits visual inspection for easy identification and repair of encapsulated parts

The operating temperature range is -60°C to 204°C and to achieve optimum properties an elevated temperature cure or a cure time of 7 days at room temperature is required.

This silicone rubber compound requires a primer to bond to non-silicone surfaces.

The optical clarity of these silicone rubber compounds suggests evaluation for applications such as potting solar cells for maximum light transmission and electronic assemblies where component identification is necessary or desirable.



TYPICAL PROPERTIES

Color	Clear
Dynamic viscosity (mixed)	4000 mPa.s
Hardness, Durometer (cured)	44 Shore A
Specific gravity (cured)	1.02
Working time (25°C)	240 min
Cured time (25°C) (150°C)	24 h 15 min
Refractive Index @ 589 nm	1.406
Shelf life from date of manufacture (25°C)	24 months

PACKAGING

500 g / 5 kg (available on stock) / 20 kg

QSIL216

Qsil216 is an ACC silicone encapsulant designed for electronic potting and encapsulation applications. It offers good protection against chemicals, environmental contamination, mechanical shock, vibration and impact damage. It can be employed in areas where low flammability is a prerequisite.

The cured elastomer can be repaired.

The component parts have relatively low viscosities and are readily mixed either by hand or machine.

DESCRIPTION & FEATURES

Qsil216 is supplied as two-part liquid.

- Mix Ratio: 10:1
- Non yellowing under UV light
- Optically clear
- Low Viscosity
- Wide temperature range



TYPICAL PROPERTIES

Color	Clear
Dynamic viscosity (mixed)	4500 mPa.s
Hardness, Durometer (cured)	40 Shore A
Specific gravity (cured)	1.02
Working time (25°C)	240 min
Cured time (25°C) (100°C)	20h 60 min
Refractive Index @ 589 nm	1.406
Shelf life from date of manufacture (25°C)	24 months

PACKAGING

250 g / 1.1 kg / 22 kg

Polyimide Silicone Tape

KAPT6338 is a polyimide film coated with a silicone adhesive. It is suitable for secondary vacuum applications (down to 10^{-7} mbar).

APPLICATIONS

KAPT6338 is an all purpose high temperature resisting tape. It is also used as a mask in the wave solder and reflow process. KAPT6338 provides a clean and safe removal after processing.

Polyester film is the most frequently used material for masking during the thin film coating and paint spraying processes. Polyimide film can be used where a high temperature mask is called for.

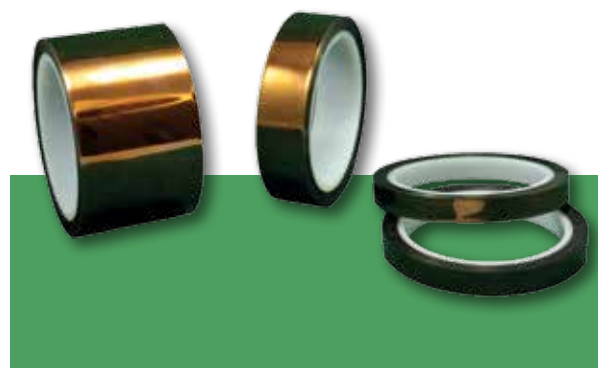

SPECIFICATIONS

PROPERTIES	DESCRIPTION
Substrate	Polyimide film
Adhesive system	Silicone
Base thickness	0.025 mm
Total thickness	0.065 mm
Peel strength	3.0 N.cm ⁻¹
Tensile strength	50 N.cm ⁻¹
Dielectric strength	7.0 kV
Colour	Bronze
Elongation	70%
Thermal classification	180°C (Class H)
Vacuum compatibility	10^{-7} mbar

AVAILABILITY

Standard rolls are 33 m long. Slit reels can be supplied to any width from 3 mm. Dots, strips and diecut parts can be supplied using this tape.

ORDERING INFORMATION (for our rolls available on stock, with one side silicone adhesive)

P/N	WIDTH (mm)	POLYIMIDE THICKNESS (mm)	TOTAL THICKNESS (mm)
KAPT6338-3	3	0.025	0.065
KAPT6338-5	5	0.025	0.065
KAPT6338-9	9	0.025	0.065
KAPT6338-10	10	0.025	0.065
KAPT6338-12	12	0.025	0.065
KAPT6338-15	15	0.025	0.065
KAPT6338-19	19	0.025	0.065
KAPT6338-20	20	0.025	0.065
KAPT6338-25	25	0.025	0.065
KAPT6338-50	50	0.025	0.065
KAPT6338-100	100	0.025	0.065

NOTE 1: Non adhesive and metallized tapes are also available upon request.

NOTE 2 : Total thickness of 65 μm enables the use of this tape as viewport protection by applying directly the tape on windows in secondary vacuum. The transparency stays good enough for observation and this makes an easy and cost effective protection.

High Precision Tweezers

We offer over 150 tweezers including Dumont® products. They are all hand made, to produce ultra-high precision instruments of superior quality and durability. Each tweezer comes individually packaged in its own plastic storage and carrying box.

MIRACLE TIP® TWEEZERS

These ultra-fine high precision tips are fabricated from a 100% Anti-magnetic Super Alloy so unique that the tips can be restraightened if they become misaligned. More corrosion resistant (tips) than anti-magnetic stainless steel, but less resistant than Gold Plated tweezers.

Available in styles #3, 3C, 4, 5.

PTFE COATED TWEEZERS

The PTFE reduces the rate of heat flow from the fingers to the tips during critical cryo work and dramatically reduces the corrosive action of acids and bases on tweezers tips such as for use with HF. The PTFE coating also tends to give at least some protection of the metal. The tweezer itself is fabricated from the highest quality stainless steel.

Available in styles #3, 3C, 4, N4, 5, N5, 5a, 7.

“BIOLOGY TIP” TWEEZERS

For the most exacting of work, where the very ultimate in sharpness is needed, and the most precision of high precision points are required.

Available in the most often asked for pattern, style #5.

ANTI-MAGNETIC STAINLESS STEEL TWEEZERS

Sharp, high precision tips make these excellent, all-purpose tweezers, especially for picking up TEM grids. Crafted from high quality, anti-magnetic stainless steel.

Available in styles #00, 0, 2, 3, 3C, 4, N4, 5, N5, 5a, N5a, 7, 7a, N7, 8.

STAINLESS STEEL (INOX) TWEEZERS

Hardest tips, but the trade off is magnetic nature and least corrosion resistance. Not recommended for autoclaving.

Available in styles #0.5, 1, 3, 5, 7a, NOC.

DUMONT® “DUMOSTAR” TWEEZERS

Dumont® “Dumostar” is a high technology alloy that has very good resistance to corrosion and is superior to that of the best stainless steel. Dumostar tweezer tips are insensitive to fatigue and never lose their elasticity. Some styles are available in a polished and/or matte finish.

DUMONT® “BIOLOGY TIP” TWEEZERS

For the most exacting of work from Dumont®.
Available in styles #3, 3C, 4, N4, 5, N5, 5a, N5a 6, 7, N7, 55.

DUMONT DUMOXEL™ ANTI-MAGNETIC STAINLESS STEEL TWEEZERS

Sharp, high precision tips, entire tweezer made from anti-magnetic stainless steel.

Available in styles #00, 2, 3, 3C, 4, 6, 7, 7A, 55, NOC.





DUMONT® STAINLESS STEEL TWEEZERS

From the Dumont® “Inox” line of high precision tip products. Not recommended for routine TEM use because of the magnetic nature of the metal being used.

Available in styles #00, 0, 1, 3, 3C, 4, N4, 5, N5, 6, 7, N7, 8, 55, NOC.



	STYLE	DESCRIPTION	P/N
	Style #00 115 mm, Sharp	Anti-magnetic Stainless Steel Dumoxel® Anti-magnetic Stainless Steel Dumont® INOX Stainless Steel	0S00P-XD 0T00M-XD 0T000-XD
	Style #0 115 mm, Sharp	INOX Stainless Steel	0T00A-XD
	Style #1 120 mm, Sharp	INOX Stainless Steel Dumostar™ High-Precision Polished	0T001-XD TD1HP-XD
	Style #2 120 mm, Sharp	Anti-magnetic Stainless Steel INOX Stainless Steel Dumoxel® Anti-magnetic Stainless Steel	0S02P-XD 0S002-XD 0T02M-XD
	Style #3 110 mm, Very Sharp	Miracle Tip® PTFE Anti-magnetic Stainless Steel Anti-magnetic Stainless Steel INOX Stainless Steel Dumoxel® Biology Tip Dumoxel® Anti-magnetic Stainless Steel Dumont® Stainless Steel Dumostar High-Precision Polished Dumostar Biology Polished	0S03X-XD 0S03T-XD 0S03P-XD 0S003-XD 0T03B-XD 0T03M-XD 0T003-XD TD3HP-XD TD3BP-XD
	Style #4 110 mm, needle sharp	Miracle Tip® PTFE Anti-magnetic Stainless Steel Dumoxel® Biology Tip Dumoxel® Anti-magnetic Stainless Steel Dumont® INOX Stainless Steel	0S04X-XD 0S04T-XD 0S04P-XD 0T04B-XD 0T04M-XD 0T004-XD
	Style #4a 110 mm long, needle sharp, but not as sharp as Style #4	Anti-magnetic Stainless Steel	0S04AP-XD

	STYLE	DESCRIPTION	P/N
	Style #5 110 mm, Needle Sharp	Miracle Tip® PTFE-Coated Bio-Miracle Tip Anti-magnetic Stainless Steel Stainless Steel Dumoxel® Biology Tip Dumoxel® Anti-magnetic Stainless Steel Dumont® INOX Stainless Steel Dumostar™ Biology Polished Dumostar™ Biology Matte Dumostar™ High-Precision Polished Dumostar™ High-Precision Matte	0S05X-XD 0S05T-XD 0S05B-XD 0S05P-XD 0S005-XD 0T05B-XD 0T05M-XD 0T005-XD TD5BP-XD TD5BM-XD TD5HP-XD TD5HM-XD
	Style #5a 115 mm, needle sharp, oblique	PTFE-Coated Anti-magnetic Stainless Steel	0S5AT-XD 0S5AP-XD
	Style #5AS 110 mm, needle sharp, anti-slip holes in handles	Anti-magnetic Stainless Steel	S05AS-XD
	Style #6 115 mm, Sharp	Dumoxel® Anti-magnetic Stainless Steel, Biology Tip Dumoxel® Anti-magnetic Stainless Steel Dumont® INOX Stainless Steel	0T06B-XD 0T06M-XD 0T006-XD
	Style #7 115 mm, Sharp	PTFE-Coated Anti-magnetic Stainless Steel Dumoxel® Biology Tip Dumoxel® Anti-magnetic Stainless Steel Dumont® INOX Stainless Steel Dumostar™ Biology Polished Dumostar™ High-Precision Polished	0S07T-XD 0S07P-XD 0T07B-XD 0T07M-XD 0T007-XD TD7BP-XD TD7HP-XD
	Style #7a 110 mm, Sharp	Anti-magnetic Stainless Steel Stainless Steel Dumoxel® Anti-magnetic Stainless Steel	0S7AP-XD 0S07A-XD 0T07A-XD
	Style #8 Length: 120 mm	Anti-magnetic Stainless Steel Dumont® INOX Stainless Steel	0S08P-XD 0T008-XD
	Style #55 110 mm, Sharp	Dumoxel® Anti-magnetic Stainless Steel, Biology Tip Dumoxel® Anti-magnetic Stainless Steel, High Precision Dumont® INOX Stainless Steel, High Precision	0T55B-XD 0T55M-XD 0T055-XD
	Style #5/45 Bent Angle Tweezers 109 mm long Bent 45°	Dumoxel® High Precision, Bent 45°	0T054A-XD
	Style #5/90 Bent Angle Tips 106 mm long Bent 90° at tips	Dumoxel® High Precision, Bent 90°	0T059A-XD

	STYLE	DESCRIPTION	P/N
	Style #N4 110 mm, needle sharp, self closing	Gold Plated™ PTFE Anti-magnetic Stainless Steel Anti-magnetic Stainless Steel Dumoxel® Biology Tip Dumont® INOX Stainless Steel	OSN4G-XD OSN4T-XD OSN4P-XD OTN4B-XD OTON4-XD
	Style #N5 110 mm, needle sharp, self closing	Anti-magnetic Stainless Steel PTFE-Coated Anti-magnetic Stainless Steel Dumoxel® Biology Tip Dumont® Stainless Steel	OSN5P-XD OSN5T-XD OTN5B-XD OTON5-XD
	Style #N5a	Anti-magnetic Stainless Steel	SN5AP-XD
	Style #N7 Self-Closing 115 mm Long	Anti-magnetic Stainless Steel Dumoxel® Biology Tip Dumont® INOX Stainless Steel	OSN7P-XD OTN7B-XD OTON7-XD
	Style #NOC	Stainless Steel Dumoxel® Anti-magnetic Stainless Steel	TNOC0-XD TNOCM-XD
	Style PP 110 mm, sharp, high precision	Stainless Steel Style PP	OSOPP-XD



ANTICAPILLARY TWEEZERS

The innovative design of these tweezers prevents water “creep” and accidental washing away of samples. These tweezers in essence stop capillary action dead in its tracks. A convenient tweezer for handling all TEM grids, the straight point can be slipped beneath the grid and the bent point will grab it without drawing water.

	STYLE	DESCRIPTION	P/N
	Style #5	PTFE-Coated Anti-magnetic Stainless Steel Anti-magnetic Stainless Steel	OS5TY-XD OS5BY-XD
	Style #N4	Anti-magnetic Stainless Steel	TN4BY-XD
	Style #N5	Dumoxel Anti-magnetic Stainless Steel	TN5BY-XD

MEMBRANE FILTER TWEEZERS

Ideal for asbestos sample preparation. Rounded "pads" with electropolished finish won't damage delicate membrane filters: plus, they allow the grasping of the very edge of a filter so as not to disturb the active sample area.

	STYLE	DESCRIPTION	P/N
	120 mm	Straight	01580-AB
	120 mm	Curved	01581-AB

 See Section J - Substrates in this catalogue for *Wafer Tweezers*.

Grids for SEM & TEM



REGULAR MESH GRIDS FOR TEM

All grids are 3.05 mm diameter, but the thickness varies with mesh size. We offer in this grid selection, thirteen different types, ranging from 50 lines/inch (e.g. 50 mesh) to 600 lines/inch (600 mesh). The lower the mesh repeat, the thinner the bar width is, in order to give the grid the desired dimensional rigidity. In other words, the 50 mesh grids are thicker than the 200 mesh grids.

Mesh sizes followed by "TT" indicate thin/thick bar matrix with an asymmetric center mark.



G50 Square Mesh



G75 Square Mesh

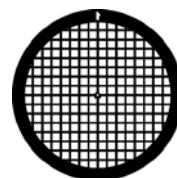

G100 Square Mesh

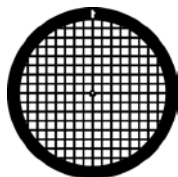

G150 Square Mesh

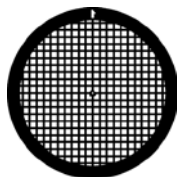

G200 Square Mesh

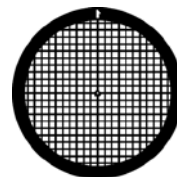

G200TT Square Mesh

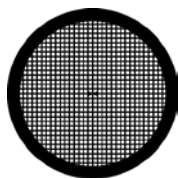

G300 Square Mesh

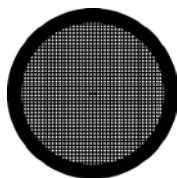

G400 Square Mesh

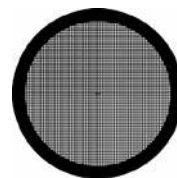

G600TT Square Mesh

Available in: Copper, Nickel, Gold, Copper/Palladium, Gold plated Nickel.

Packaging: 100 grids/vial.

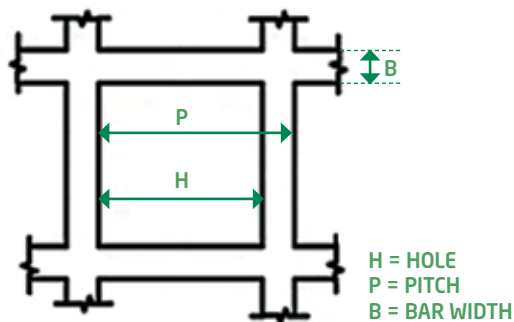

MESH SIZE	P (µm)	B (µm)	H (µm)	RIM WIDTH (mm)	CENTER MARK	RIM MARK	THICKNESS (± 3 µm)	P/N TYPE
50	500	80	420	0.225	No	No	20 µm	2005
75	340	55	285	0.225	Reverse Arrow	No	20 µm	2007
100	250	45	205	0.225	Asymmetric	No	18 µm	2010
150	165	40	125	0.225	Asymmetric	Yes	20 µm	2011
200	150	35	90	0.225	Asymmetric	Yes	20 µm	2020
200TT	125	35-25	95	0.225	Asymmetric	Yes	20 µm	202T
300	83	25	58	0.225	Asymmetric	Yes	20 µm	2030
400	62	25	37	0.225	Asymmetric	Yes	20 µm	2040
600TT	42	16-10	30	0.225	Asymmetric	Yes	20 µm	2060

Note: Other materials (Molybdenum, Aluminum, Stainless Steel, Titanium) also available upon request.

REGULAR GRIDS - MICRON TYPE

GRIDS WITH μ CENTER MARK

- Featuring asymmetric μ center mark for relocating and orienting grid squares when examining specimens.
- Available in square and non-square mesh styles, in both Copper and Nickel.
- Grids are 3.05 mm diameter unless otherwise noted. Some patterns available 2.3 mm diameter as well.

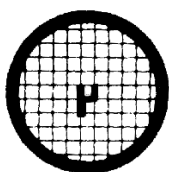

Available in: Copper, Nickel.

Packaging: 100 grids/vial.

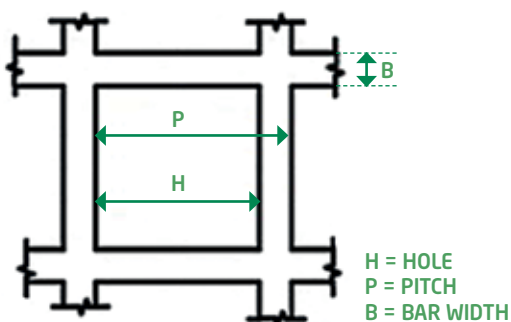

MESH SIZE	H (μm)	OPEN AREA (%)	P (μm)	B (μm)	P/N TYPE
50 SQUARE	438	76	500	62	3005
100 SQUARE	208	69	250	42	3010
150 SQUARE	132	64	165	33	3011
200 SQUARE	97	55	125	28	3020
300 SQUARE	63	55	83	20	3030
400 SQUARE	42	44	62	20	3040
600TT SQUARE (Thick-Thin bar style)	27	40	42	15	3060
200/50 RECTANGULAR	N/A	N/A	N/A	N/A	3070
400/80 RECTANGULAR	N/A	N/A	N/A	N/A	3080
1000 MESH (Vials of 20 grids each)	N/A	N/A	N/A	N/A	3100

EMICRON™ ASBESTOS INDEX GRIDS

This highly popular EMicron™ Brand TEM Asbestos Index Grid, featuring a “thick/thin” grid bar design, is in use in many of the world’s busiest asbestos testing laboratories world wide.

DESCRIPTION	P/N TYPE
Index Grid “200 Mesh”	3270

Critical Dimensions:

Diameter: 3 mm
Thickness: 10 µm

Grid Bar Widths:

Thick: 35 µm ± 5%
Thin: 21 µm ± 5%

Available in: Copper, Nickel.

Packaging: 100 grids/vial.

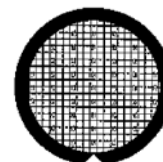

INDEX GRIDS

CALIBRATED ASBESTOS INDEX GRIDS FOR AHERA REQUIREMENTS

Each package includes:

- 1000 Asbestos Index Grids (10 vials of 100, you select the type)
- AHERA-Required Documentation of Open Area Calibration
- Available in Copper
- 200 mesh

INDEX GRIDS FOR QUANTITATIVE TEM STUDIES

- Alpha-Numeric Indexing on Grid Perimeter
- Asymmetric Center Mark
- Available in Copper, Nickel, Gold
- 200 mesh
- 125 µm mesh pitch
- Vials of 100 grids

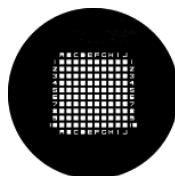

Type 2270

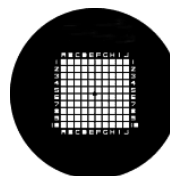

Type 2280

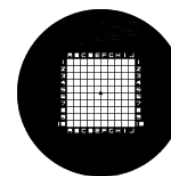

Type 2290

PRODUCT	OPEN AREA (%)	BAR WIDTH (µm)	GRID SQUARE (µm)	P/N TYPE
Regular	55	30	95	2270
SuperGrid™	74	20	105	2280
Slim Bar®	84	10	115	2290

OTHER GRIDS FOR TEM

SLIM BAR GRIDS

The Slim-Bar® Grids were designed for those who want the very maximum of open area when viewing their important samples.

- Available in regular square, variable rectangular and hexagonal mesh grid squares when examining specimens
- Thickness of all grids: 20.3 µm

Available in: Copper, Nickel, Gold, Gold plated Nickel and Gold Plated Copper.

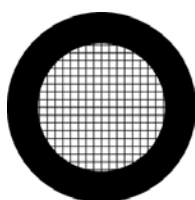

G200HS

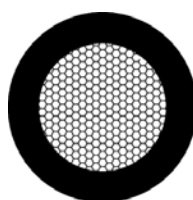

G200HH

APERTURE GRIDS

- Allows the microscopist to see a complete sections without grid bar interruption
- Smooth edges
- Excellent dull/shiny side discrimination
- Hole diameter varies from 50 µm to 2000 µm

The thickness of a particular grid pattern depends on the size of the hole, the larger the hole, the thicker the grid, in order to give the grid better dimensional stability and stiffness. The thickness varies from 25 µm ±3 µm for the smallest hole to 50 µm ± 5 µm for the thickest.

Available in: Copper, Nickel, Gold, Copper/Palladium, Gold plated Copper and Gold plated Nickel.

Packaging: 100 grids/vial.



**50 µm Hole
Diameter**

TEM COATED GRIDS AND CUSTOM COATING SERVICE

Please contact Neyco for TEM coated grids and custom coating service in:

- Formvar®
- Formvar®/Carbon reinforced
- Carbon
- Holey Carbon
- Holey Formvar®, Carbon coated
- Lacey Carbon
- Lacey Formvar®, Carbon coated
- Holey Silicon Dioxide (SiO₂)/Silicon Monoxide (SiO)
- Silicon Dioxide (SiO₂)/Silicon Monoxide (SiO)

QUANTIFOIL® CARBON COATED GRIDS: SPECIAL HOLEY CARBON FILMED GRIDS

Quantifoil is a perforated support foil with a precisely pre-defined hole size, shape, and arrangement. The use of these support foils as “support films” on TEM grids offers a number of advantages not only for conventional transmission electron microscopy (TEM), but also for low-energy point source (LEEPS) microscopy when compared with conventional holey Carbon support films.

QUANTIFOIL HOLEY CARBON SUPPORTED GRIDS, CIRCULAR HOLES

Packaging: 100 grids/pack.

Available in: Copper, Nickel, Rhodium plated Copper, Gold.

	R 2/1	R 2/2	R 2/4	R 1.2/1.3	R 1/4	R 3.5/1	R 0.6/1 ⁽¹⁾	R 5/20
Hole Size (µm)	2	2	2	1.2	1	3.5	0.6	5
Space between holes (µm)	1	2	4	1.3	4	1	1	20
Center to center (µm)	3	4	6	2.5	5	4.5	1.6	25
Type 200 Mesh (square)	4320 ⁽²⁾	4420	4520	4220	4870	4820	4962	4966
Type 300 Mesh (square)	4330	4430	4530	4230	4880	4840	4963	4967
Type 400 Mesh (square)	4340	4440	4540	4240	4890	4850	4964	4968
Type 100x400 Mesh (square)	4350	4450	4550	4250	4810	4860	4965	4969

(1) Hole size might be as large as 1 µm.

(2) Available also in Molybdenum.

SILICONE NITRIDE MEMBRANE WINDOWS FOR TEM AND X-RAY MICROSCOPY

SQUARE WINDOWS: SILICON NITRIDE MEMBRANE WINDOW GRIDS FOR TEM

These unique membranes of Silicon Nitride (Si_3N_4) were made using an electronic grade Silicon wafers with a thin film of Si_3N_4 deposited to the desired thickness.

- For SEM applications, the background is relatively structureless and featureless (remember, nothing is completely structureless or featureless).
- For X-ray microscopy there is really no other way for mounting many of the samples one would want to analyze.
- For SEM BSE imaging, cells can be grown directly onto the nitride windows and the volume sealed with a “blank” without membrane for a perfect UHV compatible environmental chamber.

Packaging: packs of 10 (except for 50 μm : 100).

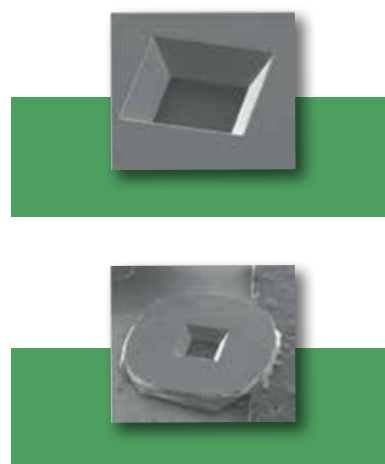

THICKNESS OF MEMBRANE WINDOW	200 μm THICK FRAMES						100 μm THICK FRAMES	50 μm THICK (ULTRATHIN) FRAMES
	WINDOW SIZE							
	5.0 mm	1.0 mm	0.5 mm	0.25 mm	0.10 mm	50 μm	0.5 mm	0.5 mm
500 nm	-	-	4109SN-BA	4098SN-BA	4091SN-BA	-	-	-
200 nm	4164SN-BA	-	4120SN-BA	4099SN-BA	4092SN-BA	-	-	-
150 nm	-	4161SN-BA	4121SN-BA	4100SN-BA	4093SN-BA	-	-	-
100 nm	-	4112SN-BA	4122SN-BA	4101SN-BA	4094SN-BA	4088SN-BA	4131SN-BA	4160SN-MB
75 nm	-	-	4123SN-BA	4102SN-BA	4095SN-BA	-	-	-
50 nm	-	4135SN-BA	4124SN-BA	4103SN-BA	4096SN-BA	-	4132SN-BA	-
30 nm	-	4162SN-BA	4125SN-BA	4104SN-BA	4097SN-BA	4090SN-BA	4192SN-BA	-
20 nm	-	-	4159SN-BA	4105SN-BA	4107SN-BA	4163SN-BA	-	-

Please contact Neyco for other dimensions in Si_3N_4 membranes as well as for SiO_2 membranes.

Tripod® Polisher for Sample Preparation

TRIPOD POLISHER

The Tripod Polisher is designed for preparing cross-sections of materials for both SEM and TEM. It is extensively used for preparing unencapsulated IC cross-sections for SEM and has the added capability of preparing the same sample for TEM. Similar techniques are used in preparing samples from virtually any material for both SEM and TEM and the Tripod Polisher has been successfully used to minimize and even eliminate ion milling of TEM samples. A wide range of accessories for the Tripod Polisher is available as well.

The Tripod Lab Starter Kit consists of the following items:

- Diamond Lapping Film; plain backed, 20.3 cm diameter (1 each of the following sizes: 30, 15, 6, 3, 1, 0.5 μm)
- Multitex™ polishing cloth, 20.3 cm diameter
- Glass Plate, 20.3 cm diameter, 6.3 mm thick
- Colloidal Silica, 0.05 μm particle size, 473 ml
- Mounting wax, QuickStart™ 135 crystal clear acetone soluble wax
- Slotted TEM grids, Cu, hole size: 2 x 1 mm
- Sample cleaner, TriClean® 590
- Petri dish, 10 cm diameter
- Filter, Qualitative, 9 cm diameter. One box of 100 packs is supplied. Used for bottom of petri dishes
- Tweezer set includes one pair of tongs and one self-closing high precision tweezers
- Scotch pad abrasive added to one side



DESCRIPTION
Tripod Polisher TEM 590W
Starter Kit of consumables
Spare Parts: Replacement Delrin feet, Pk (3)

Crystalbond™

Crystalbond™, mounting adhesives are ideal materials for temporarily mounting objects that require dicing, polishing, and other machining processes. These adhesives exhibit high bond strength and adhere readily to metals, glass and ceramics.

TYPICAL APPLICATIONS

- Machining advanced ceramics
- Lapping and polishing optical components
- Dicing ceramic substrates and semiconductor wafers
- Dicing ferrites, glasses and piezoelectrics
- Dicing metal and optical single crystals
- Mounting cross-sections for electron microscopy
- Back filling components for temporary mechanical support

PRODUCT NO.	509	555	555-HMP	590
Form	Stick	Stick	Stick	Stick
Size (mm)	22.22 x 25.4 x 177.8	12.7 x 25.4 x 177.8	12.7 x 25.4 x 177.8	15.88 x 31.75 x 190.5
Weight (g)	90 g/stick	68 g/stick	68 g/stick	226 g/stick
Flow Point (°C)	121	54	66	150
Viscosity, Pa.s	6	0.5	0.5	9
Color	Clear to dark amber	White	White	Brown
Solvent	509-S or Acetone	Hot Water	Hot Water	590-S or Methanol

ORDERING INFORMATION

PRODUCT	PACKAGING	P/N
Crystalbond 509 (Clear Color)	1 Stick	05110-AB
	Pack of 5 Sticks	05110-AF
Crystalbond 509 (Light Amber)	1 Stick	05110LA-AB
	Pack of 5 Sticks	05110LA-AF
Crystalbond 509 (Dark Light Amber)	1 Stick	05110DA-AB
	Pack of 5 Sticks	05110DA-AF
Crystalbond 555	1 Stick	05111-AB
	Pack of 10 Sticks	05111-BA
Crystalbond 555 HMP (Low Melting Point)	1 Stick	05112-AB
	Pack of 10 Sticks	05112-BA
Crystalbond 590	1 Stick	05113-AB
	Pack of 2 Sticks	05113-AC

Cargille Refractive Index Fluids

The standard group of Cargille Refractive Index Liquids consists of a total of 220 RI liquids divided into six different RI series in the range from 1.300 to 1.800. The Certified Series cover the range of the most minerals, most chemicals, and practically all biological materials.

PRODUCT	RI RANGE	NO. OF RI. LIQUIDS
Series AAA	1.300 to 1.395	20
Series AA	1.400 to 1.458	30
Series A	1.460 to 1.640	91
Series B	1.642 to 1.700	30
Series M	1.705 to 1.800	20
Series E (High Dispersion)	1.500 to 1.640	29

Packaging: 7 ml and 30 ml

Supplied with certificate statement.



Plasma Matrix Series (2 gas entries)

Table Top RF plasma reactor system series for most of the Cleaning/Etching process in R/D or small Industrial pilot production (from 2.5 to 40 litres SS 304 vacuum chambers)

The Plasma Matrix & Super Plasma Matrix table top plasma reactors are designed to fulfill most of the R/D and industrial application of plasma cleaning, etching and surface activation where the initial machine investment has to be kept very low.

The easy and friendly use (through a LCD touch screen display) of the tool software together with the optimized design of the SS vacuum chamber of the Matrix series, put them on the top level of what offered by the today market

The Matrix plasma reactors series includes all the functions needed to keep the plasma process stable and repeatable as required by different R/D and industrial applications.

APPLICATIONS:

- Plasma activation
- Plasma etching
- Low temperature Plasma ashing
- SEM and TEM sample preparation
- Fine cleaning of high precision mechanical parts
- Textile surface treatments
- Microfluidics component treatment
- Ophthalmic (contact lens wettability)
- Plastic treatment before printing or painting processes
- Sterilization of medical equipments
- Dental implant cleaning treatment



Two versions of the Plasma Matrix are currently available:

- Plasma Matrix Plus with 2.5 litre SS 304 vacuum process chamber, two gas inlets and manual inductive matching network with up to 200 Watt RF 13.56 MHz generator,
- Super Plasma matrix with 40 litre SS vacuum process chamber, two gas inlets and a full capacitive auto matching network with up to 300 Watt RF 13.56 MHz generator.

Small Tools

DIAMOND SCRIBES

The sharp diamond tip retracts with a push on the top button. The pen-style design is manufactured to produce a wobble free "fit" between the outer barrel and the refill holding the diamond. Use for preparing and marking samples to be examined by SEM and just plain ordinary glass slides and photographic plates and also for scribing and trimming silicon, ceramics and other hard materials.

The high-precision "feel" has made the diamond scribes very popular for high volume and production work of all kinds.

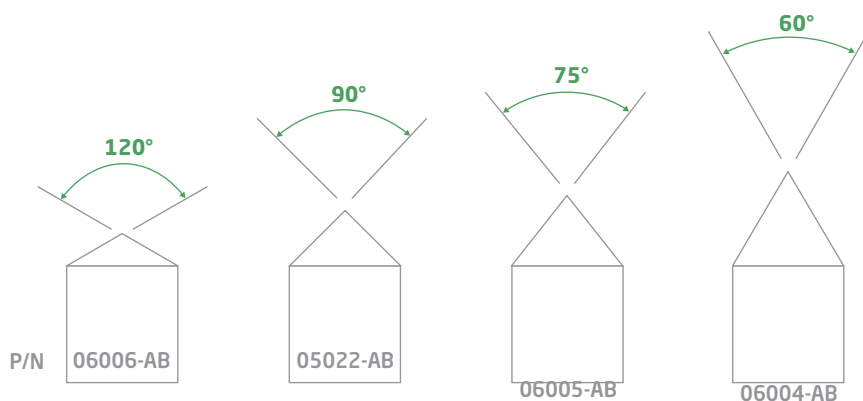

The standard product comes with a diamond 0.9 mm (0.035") to 1.0 mm (0.040") diameter, with an exposed angle of 90-100 degrees. The radius of curvature at the tip is on the order of 25.4 μm (0.001") to 50.8 μm (0.002"). The Diamond Scribe products are all made from natural diamond and as nature has never made two diamonds exactly the same, there will be some variation from one diamond to another but we keep such variations within reasonably tight specifications.

The Diamond Scribe Refill has been designed to use with the Diamond Scribe. The refill consists of a diamond cutting point mounted in a tube having the appearance of a ball point pen refill. The tube is 105 mm long by 3 mm in diameter.

	INCLUDED ANGLE: 60°	INCLUDED ANGLE: 75°	INCLUDED ANGLE: 90°	INCLUDED ANGLE: 120°
Pen	06004-AB	06005-AB	05022-AB	06006-AB
Refills	06004R-AB	06005R-AB	05023-AB	06006R-AB

GEM® SCIENTIFIC BLADES

These are the highest quality single-edge razor blades useful for mincing specimens, trimming tissue blocks, etc.

Dimensions:

Length: 40 mm

Width: 20 mm

Thickness: 0.23 mm along the cutting edge; up to 1 mm along the top of the blade.

Hole: 6.1 mm high x 2.5 mm

Packaging:

Handy packs of ten are secured within an all plastic safety dispenser.

DESCRIPTION	P/N
Individual cartridges (Safety Pkg/10)	05025-AB
Bulk package of 100 blades in one container (Bulk Pkg/100)	05025-MB



neyco

30 avenue de la Paix
92170 Vanves - France
Tel: +33(0)1 41 90 50 50
Fax: +33(0)1 41 90 50 51

www.neyco.fr



Materials L 2018-1

neyco

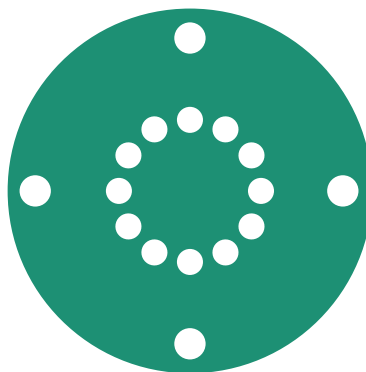

MATERIALS VACUUM DEPOSITION

- Magnetrons M 02
- Power Supplies M 06
- Ion-Guns M 13
- Electron-Guns M 14
- Electron & Ion-Gun Parts M 21
- Thin Film Deposition System M 25
- Thin Film Deposition Services M 27

Magnetrons

CIRCULAR MAGNETRONS

Our circular magnetrons have rapidly become recognized as the new standard of the sputtering industry. In addition to their advanced features such as profiled magnets, turbulent water flow, and solid stainless steel construction, they offer other performance efficiencies as well.

VERSATILE, COMPACT DESIGN

Their ultra-compact design makes them ideal for virtually any new or retrofit application – including the most complex multiple-cathode deposition clusters or the smallest vacuum chambers. And they can easily be configured for either internal or external mounts.

TOTAL POWER COMPATIBILITY

Their low-impedance heads provide RF, DC, mid-frequency DC, pulsed DC, and microwave power compatibility.

STANDARD FITTINGS

We use ISO NW standard fittings, as well as ConFlat® metal seal flanges. All utilities are maintained at atmosphere, and are accessed through standard O-ring compression fittings for ease of installation in any vacuum system.

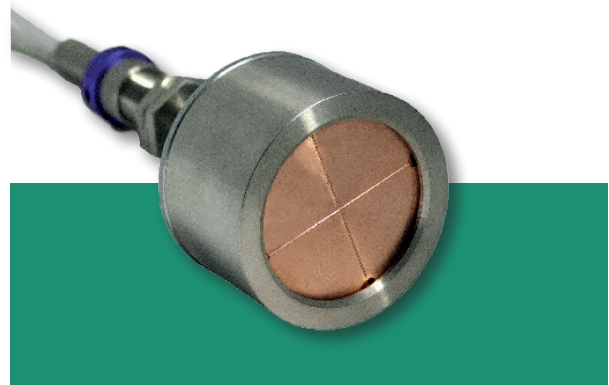

FULL RANGE OF SIZES

Our circular magnetron sources are available in 1", 2", 3", 4", 5", 6", 8", 10", 12", and 16" target sizes.

QUICK, EASY TARGET CHANGE

The patented threaded clamp and anode shield allow you to change targets (sizes 1" to 6") quickly and easily without specialized tools, and their built-in adjustability lets you fit targets of varying thickness without resorting to spacing devices. Standard targets clamping also available.

LOWER PRESSURE, HIGHER POWER

Our Magnetrons can operate at extremely low pressure – down to the 10^{-4} Torr range – and our directly cooled designs can deliver power densities up to 39 W/cm².

HIGHER RATES AND PERFORMANCE

This means our magnetrons can coat a greater area for their cathode size than other magnetrons. So you can maximize both your coating zone and your target utilization without the kind of trade-off in rate that other magnetrons force you to make.

RECOMMENDED POWER PER TARGET SIZE

	DC	RF
1"	500 W	200 W
2"	1 kW	300 W
3"	1 kW	300 W
4"	2 kW	600 W



GREATER TARGET UTILIZATION

Yet these same advanced magnetrons can give you target utilization up to 50%.

GREATER UNIFORMITY

And, thanks to the patented profiled magnets, our magnetrons also deliver much greater uniformity of deposition – routinely in the ± 3 to 5% range.

OPTIONS

- Manual or pneumatic shutter
- Right angle
- $\pm 45^\circ$ tilt
- Balanced, unbalanced
- Gas injection
- Cheminey
- High strength magnet array
- In-situ variable magnetic field



CYLINDRICAL MAGNETRONS

We have developed a rotating cylindrical magnetron assembly that is compact, economical, and lightweight. By utilizing the patented technology we provide low flux deposition profile, +85% target utilization, and power savings up to 20% compared to conventional cylindrical magnetrons.

Customized for Flat Panel Display, Web Coating and Solar Cell applications.

Complete assemblies are available from 3" - 6" (76.2 mm - 152.4 mm) in diameter and up to 4 m in length.

Other features include:

- High Magnetic Field provides a low operating voltage for reduced power requirements.
- An optimized electrical transfer design to deliver high power while avoiding arcing as well as reduced brush wear and debris.
- A KF quick connect water-to-vacuum seal for quick target changes, shorter down times and increased production.
- A universal and cost effective magnet design with customized turnarounds.

Lightweight, easily-serviced product with off-the-shelf components for low-cost, long-term investment and reliability.

"THROUGH THE WALL" STRAIGHT-THRU CYLINDRICAL MAGNETRON SOLUTIONS

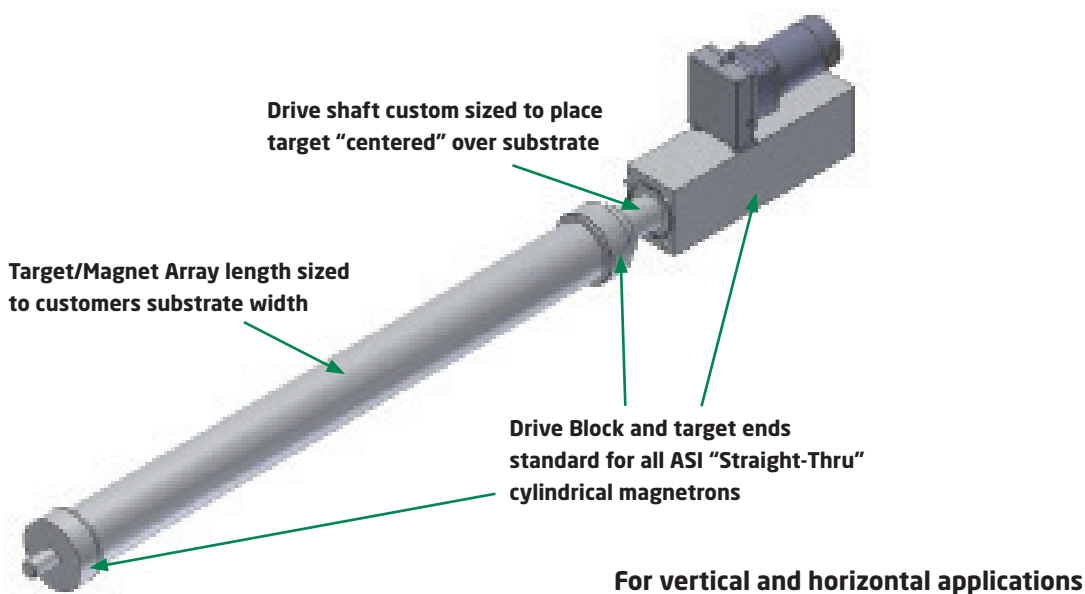

RECTANGULAR MAGNETRONS

As more and more industries discover the speed, controllability, and bottom-line benefits of magnetron sputtering, production professionals are reaching out for ways to apply these advantages to larger, faster manufacturing processes.

BROADER SOLUTIONS

For many, particularly those who have to coat broad physical substrates or achieve extremely high throughput, rectangular magnetrons offer the perfect solution.

GROWING APPLICATIONS

That's why the use of rectangular magnetrons is growing so rapidly in industries such as:

- Aerospace
- Architectural glass
- Authentication
- Automotive
- Decorative coating
- Defense
- Flat panel displays
- Magnetic storage media
- Medical/Dental
- Optical
- Packaging
- Semiconductors/Microelectronics
- Solar
- Wear-resistant coating

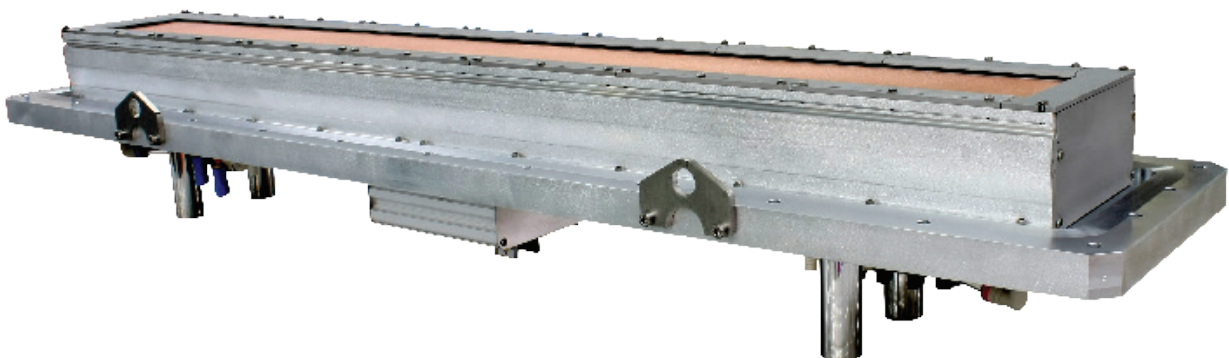

Power Supplies

DC POWER SUPPLIES DC 05 - DC 30 FOR SPUTTERING APPLICATIONS

The compact power supplies were developed for small magnetrons in production plants and laboratories. Easy and safe operation make these power supplies very flexible for many processes. The arc-handling adjusts automatically to different process parameters, so that programming is not necessary. The units are designed for mounting in 19" racks.

The DC Power supplies DC 05 - DC 30 are **CE Compliant**.

SPECIFICATIONS

	DC 05/1000	DC 10/1000	DC 12/2000	DC 15/1000	DC 20/1000	DC 30/1000
Nominal power*	0.5 kW	1 kW	1.2 kW	1.5 kW	2 kW	3 kW
Output voltage	1000 V		2000 V	1000 V		
	Plus pole grounded					
	Option: Minus pole grounded, tight beam			Option: Floating		
Output current	0.7 A	1.4 A	1 A	2.4 A	2.8 A	4.2 A
Control	Current, voltage or power controlled					
Mode of operation	Manual via front panel or external via A/D interface AS 4, AS 4 F or Profibus					
Set point	0 ... 100 % of nominal voltage, current or power					
Output accuracy	±1% of nominal value for voltage, current and power					
Arc suppression	Quenching time: 6 µs up to 3 ms, automatically Delay time 6 µs up to 10 ms, automatically					
Indications	3,5" digit display for voltage, current and power					
Noise	$L_{pA} < 70$ dB (A)					

* Other nominal power available on request, up to 50 kW.

Mains connection	230 V, +5 % / -10 %, 50/60 Hz, (Option: 200 V, L1, L2, PE)			3 x 400 V, +5 %/ -10 %, 50/60 Hz, (Option: 3 x 200 V, only GS 15 and GS 20), PE		
Mains connection	230 V, +5 % / -10 %, 50/60 Hz, (Option: 200 V, L1, L2, PE)			3 x 400 V, +5 %/ -10 %, 50/60 Hz, (Option: 3 x 200 V, only GS 15 and GS 20), PE		
Power consumption	0.6 kVA	1.2 kVA	1.4 kVA	1.8kVA	2.4 kVA	3.6 kVA
Fusing	6 A	6 A	10 A	6 A (10 A)	6 A (10 A)	10 A
High voltage connection	RG 213 or JZ-600-Y-CY, 2 x 1.5 mm ²					
Cooling	Forced air, maximum ambient temperature 40° C					
Size	1/2 19" slide-in, 3HU (132.5 mm), 560 mm deep					
Weight	11 kg			12 kg		

RF 200 300 750 FAMILY ACTIVE FRONT PANEL FOR SPUTTERING APPLICATIONS

NEYCO introduce a new family of low-medium power RF generators intended to satisfy the needs of laboratory grade and small low pressure industrial plasma systems.

These generators are **CE Compliant**.

Model **RF200-300-750.AFP** 200, 300 and 750 W, Active Front Panel, direct tuner interface, optional external module.

The low-medium power AFP (Active Front Panel) series is a ½ rack mounted generator with direct tuner control and AFP with LCD touch screen display, friendly user interface software and RS 232-Profibus interfaces up on request. The unit can be configured also to drive 2 Auto matching networks as option.

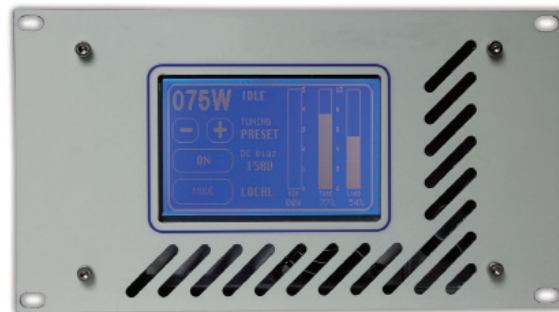

Common SPECIFICATIONS of **Active Front Panel generator** families:

- The analog control module and the RF module are common to all families.
- The RF mosfet type, output tuning elements and DC switching power supply.
- The BDS RF series is a class E circuit with 85-90% typical efficiency.
- The output power is modulated by means of a PWM circuit acting on the DC bus.

SPECIFICATIONS FOR ACTIVE FRONT PANEL VERSION

Dimensions	132.5 x 269 x 410 mm
Weight	About 5 kg
Power requirements	World wide mains supply 120 to 240 VAC 50-60 Hz with PFC
Operating frequency	13.56 MHz ± 0.005 % quartz controlled
Output power on 50 Ohm load	From 4 to max 750 W (different FS versions)
Maximum reflected power	20 %
Harmonic content	-40 dB below fundamental
Power detector	Forward and reverse power, linear scale 3% accuracy
Protection circuits	Excess reverse power, over temperature PA (Power Amplifier) overvoltage, PA over current
RF Output connector	N, female
User Interface	User friendly LCD touch screen display
User port connector	D-Type 9 pin, female Interlock function and remote RF ON
Interfaces	RS 232 - Profibus for remote control (up on request)
Tuner control	Full interfacing capability with matching units series BDS-AMXXX
Matching network port	D-Type 25 pin female
Operating temperature	From 10 to 40°C, No condensation or icing
Cooling	Forced air with 80mm fan
Note	Optional: driver module for N° 2 auto matching networks

BAA 600 AUTO MATCHING UNIT FOR RF SPUTTERING

NEYCO is introducing a new family of automatic matching network units operating at the standard ISM frequency of 13.56 MHz intended for industrial and laboratory use.

The BAA 600 Auto is **CE Compliant**.

Typical applications include sputtering process, PECVD deposition, plasma activation, dielectric heating, laser excitation and more. The two standard configurations are L type network that best fits low impedance loads and TEE configuration for medium impedance loads.



Model BAA 600: Auto Matching based on variable air caps rated for 3000 V and 16 A analog user port pin compatible with BDS.HF 200-300 and 750 W generator's family.

The BAA600 is an auto matching unit to be used in HF (13.56 MHz) plasma application, transform the complex impedance of the load in a 50 Ohm resistive. The tuning circuit is L type using high quality variable caps and precision positioning motors. Typical tuning type is less than 2 seconds.

A wide range of full preset or one channel only preset is possible. It's also possible a full independent operation with only one external switch to recall ignition position is required.

A DC BIAS measurement circuit permits to monitor DC bias, scaled of a factor of 100.

SPECIFICATIONS

Tuning Elements	High grade air variable capacitors with high current sliding contacts. Option one vacuum capacitor in order to achieve higher cathode Voltage and current
Power supply	24 VDC 800 mA max. (from the Neyco's HF generators or via an external P.S.)
Analog I/O	10 V full scale
Digital I/O	24 VDC isolated
Input RF	N type female
Output RF	7/16 female to be used with RG393 Teflon cable
Max cathode voltage	3000 VAC + DC
Max cathode current	16 A RF
User connector	D15 pin female
Operating modes	N, female
Detector Type	Passive phase magnitude detector, signal reversing possible
Dimensions	190 x 340 x 175 mm

Direct interfacing with all Neyco's series RF generators.

3 Channel output (vacuum relays) option.

HIPMS & PULSED DC power supplies also available.

 See more in our website: www.neyco.fr

PROGRAMMABLE DC POWER SUPPLIES FOR THERMAL APPLICATIONS

FEATURES

- High power density: 3.3 kW, 5 kW, 10 kW, 15 kW
- Output Voltage up to 600 V, Current up to 400 A
- Built in RS-232 & RS-485 Interface Standard
- Advanced Parallel Operation
- Optional Interface: LXI Compliant LAN / IEEE 488.2 SCPI (GPIB) Multi-Drop / Isolated Analog Programming
- LabView® and LabWindows® drivers



Programmable DC Power supplies are **CE Compliant**.

	3.3 kW	5 kW	10 kW	15 kW
AC inputs	Single-phase (230 VAC) & Three-phase (208 VAC, 400 VAC)	Three-phase (208 VAC, 400 VAC)	Three-phase (208 VAC, 400 VAC, 480 VAC)	
Output voltage	Up to 600 V		From 7.5 V to 1500 V	
Output current	Up to 400 A	Up to 600 A	Up to 1000 ADC	
Active Power Factor Correction	Single-phase & Three-Phase AC Input	Three-phase AC Input	Passive Three-phase AC Inputs	
Output current	0.7 A	1.4 A	1 A	2.4 A
Control	Independent remote ON/OFF and remote Enable/Disable			
Mounting	19" Rack Mount capability for ATE and OEM applications			
Driver	LabView® and LabWindows® drivers			
Warranty	Five years, CE Mark			

DC GLOW DISCHARGE DC POWER SUPPLIES FOR PLASMA APPLICATIONS

The BDS-GLOW is a DC High Voltage Power Supply, specifically designed for plasma glow discharge. Is available in the 2000 or 4000 V with 3 kW power capacity full scale with positive or negative output.

Several protection and limiting circuits have been implemented to satisfy the most critical applications. The arc detection circuit sense plasma arcing end cause immediate shutdown and restart after an user-defined dead time. Overcurrent, overvoltage, over temperature circuits are included.

The high frequency inverter is equipped with last generation IGBT transistor obtaining mains to output efficiency greater than 90 %.

The interfacing with user application can be by analog user port or Optional RS-232. The front panel is equipped with LCD display and active front panel is available as option for local manual control.

DC glow discharge DC Power supplies is **CE Compliant**.

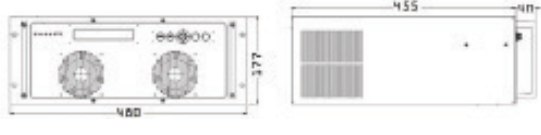

SPECIFICATIONS

Output voltage	From 300 V to 4000 V	From 150 V to 2000 V
Output current	Up to 800 mA	Up to 1.6 A
Output polarity	Negative, (or Positive on request)	
Output connector	Fischer, type 105, 10 kV rating for RG213 coax cable	
Mains input	3 x 400 VAC ±10% 50 Hz (L1, L2, L3PE)	
Dimensions		
Weight	12 kg	
Cooling	Forced air	
Working temperature	15-35 °C	
Protection circuits	Inverter over temperature Mains under - overvoltage Output current limit (LED Overcurrent) Output overvoltage	
ARC Handling	dV / dT soft start ramp	
Interfacing	Analog user port with 10 V scaled signals and 24 V digital commands on DB25	
Interlock	Contact closure to enable HV output	

MF GENERATOR FOR PLASMA APPLICATIONS

The BDS-MF is a 40 kHz plasma generator with max power delivery of 5 kW or 10 kW specifically designed for plasma excitation on PECVD or plasma cleaning applications.

The unit is capable of delivery up to 10 kW (or 5 kW) at 5000 V RMS output. The output is balanced type, capable to drive 2 symmetrical electrodes. Typical application is PECVD process on large process chambers. A unique features is the high voltage matching transformer built in 2 (standard) or 3 (on request) transformer taps are available as impedance matching.

User only needs to connect two coaxial cables to the electrodes. Interface with the user's PLC can be both analog or digital RS-232 or Profibus (upon request).

MF Generator for plasma application is **CE Compliant**.



FEATURES

- Output matching transformer is built in. No external box is required.
- Air cooled unit. No risk associated with moisture or water leakage
- Full power with ambient temperature up to 40C°
- Analog interface
- Fieldbus interface available upon request
- Front panel display makes installation and troubleshooting easier
- High efficiency >90%
- Compact and lightweight construction, only 20 kg, 4UI

SPECIFICATIONS

	MF5k	MF10k
Output Load	5 kW on 2000 Ω load	10 kW on 2000 Ω load
AC Supply	3 x 400 VAC ± 10% 50 / 60 Hz, 10 A (L1, L2, L3, PE)	3 x 400 VAC ± 10% 50 / 60 Hz, 18 A (L1, L2, L3, PE)
Dimensions	19" rack style, 4UI height (177 mm) 540 mm depth	
Weight	20 kg, hard robust aluminum case	
Cooling	Forced air, high efficiency heat sinks operate up to 40°C ambient temperature	
Output voltage	Up to 5000 V (7000 V as option) on tap2 at 2000 Ohm load	
Output current	Up to 3,5 A on tap1, Up to 2,5 A on tap2	
Output Connection	Balanced 2 x Fischer 105 connectors for RG214/U coaxial cable	
Ignition voltage	Greater than 5500 Vrms	
Arc detection	Based on primary overcurrent, 1 microsecond reaction time	
User interface	DB25 connector, analog signal 10V, digital 24V pinout compatible with Advanced Energy PEII® RS232 or Profibus (optional)	
Front panel	LCD display 2x40 characters highly readable	
Protection	Overcurrent, open load, arcs, mains under voltage, over-temperature	
Measurement	RMS voltage, RMS current, active power delivered	
Regulation	Power regulation mode	
HV transformer	Built in 2 taps 1000 Ω, 2000 Ω	
Designation	CE Declaration of conformity available upon request	

Ion-Guns

GRIDLESS CIRCULAR ION-GUN

The Ion-Gun boasts a long maintenance cycle - both in reactive and inert environments - and has an operational range of up to 90 mA and up to 3 kV. There is no contamination, which makes the product suitable for semiconductor applications. Other applications include substrate pre-clean, ion assist, etch/texturing and PACVD deposition. It is easy to fit, with a 1" shaft mount and outer diameter of 5", and is an ideal pair for new 3" and 4" circular full face erosion magnetrons.

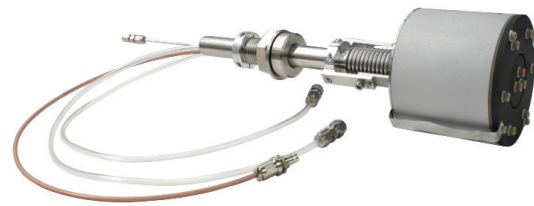

FEATURES

- Inversed magnetron ion beam
- Self neutralised ion beam
- Operating pressure in large pressure range (10^{-4} to 10^{-3} mbar)
- Tilting head - ion angle control
- Stable ion beam current and ion energy distribution
- Feedback control
- Variety of gas feed possible
- No contamination
- Suitable for Semiconductor industry

ION ETCHING APPLICATIONS

- Nanotexturing
- Coating removal
- Improving coating adhesion
- ITO and silver deposition assistance
- PACVD - DLC deposition
- Ion beam deposition

Power supply available on request.

Electron-Guns

HC SERIES, HIGH CAPACITY EVAPORATION SOURCES

FEATURES

- 270° beam deflection
- Long life emitter assembly
- Easy filament replacement
- Permanent magnet beam positioning
- Multiple crucibles
- Large crucible volume
- Interchangeable crucible assemblies

The HC Series e-Gun evaporation sources deliver superior results in demanding production coating applications. Large crucibles permit long, uninterrupted evaporation runs. Disassembly and assembly are quick and easy. Maintenance time is reduced. HC e-Guns are designed to provide maximum service life.

270° BEAM DEFLECTION

The HC incorporates a proven 270° electron beam deflection system. The filament is hidden below and out of the line-of-sight of the crucible. This prevents ion erosion and provides maximum protection from shorting caused by stray particles or condensate.

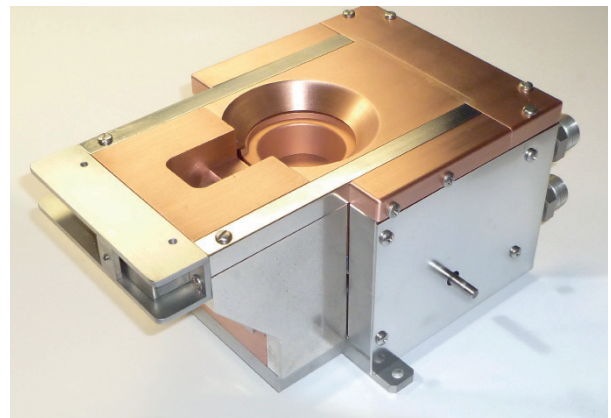

LONG LIFE EMITTER ASSEMBLY

The 270° electron beam deflection design has been enhanced with a new and improved emitter assembly.

EASY FILAMENT REPLACEMENT

The emitter assembly design makes removal or replacement of the filament fast and easy. A filament alignment tool maintains critical filament tolerances, allowing quick and accurate filament replacement

PERMANENT MAGNET BEAM POSITIONING

Primary beam position is controlled by a permanent magnet. Electromagnets are used for precise positioning and beam sweep.

MOUNTING CONFIGURATIONS

Each gun is available in three standard mounting configurations:

1. E-Gun alone with no mounting flange.
2. E-Gun with a 1" diameter bolt-type mount, which mounts through a 1" diameter hole, and is sealed by a compression O-ring.
3. E-Gun mounted on a ConFlat metal seal type flange, which uses a standard OFHC copper gasket.

Custom Mounting is available. Please consult Neyco.

UNIVERSAL INSTALLATION

An optional universal mounting adapter plate is available. The plate permits the direct mounting of HC E-Guns into existing or similar evaporation source installations.

SPECIFICATIONS

Maximum power	7 cc - 10 cc: 6 kW 15 cc - 25 cc: 10 kW 40 cc: 15 kW
Emission voltage	-4 to -10 kV
Emission current	0 to 1 A
E-beam deflection	270°
Beam spot size	0.25" dia., tight beam
Evaporation rate	up to 1 gr/min at 10 kW 36 000 Å/min Al at 250 mm source-to-substrate distance
X and Y sweep	Longitudinal and lateral control up to 200 Hz when operated with sweep controller
Water	3 gpm, 20°C, 3 to 4 bars pressure differential
Crucible material	OFHC copper
Bakeout temperature	HCF - Fixed 230°C HCR - Rotary 120°C HCL - Linear 230°C

HCR ROTARY

The HCR offers interchangeable crucible blocks, available in a variety of volumes and geometries. Five standard crucible arrangements, illustrated in Fig. 2, offer the flexibility necessary for a wide variety of source materials, applications, and processes. HC crucible block assemblies can be removed, exchanged, or replaced easily and quickly from the top of the e-Gun.

Custom: Note Fig. 2 "FIGURE 2.6" represents one custom crucible configuration. Please consult Neyco for a custom design to meet your requirements.

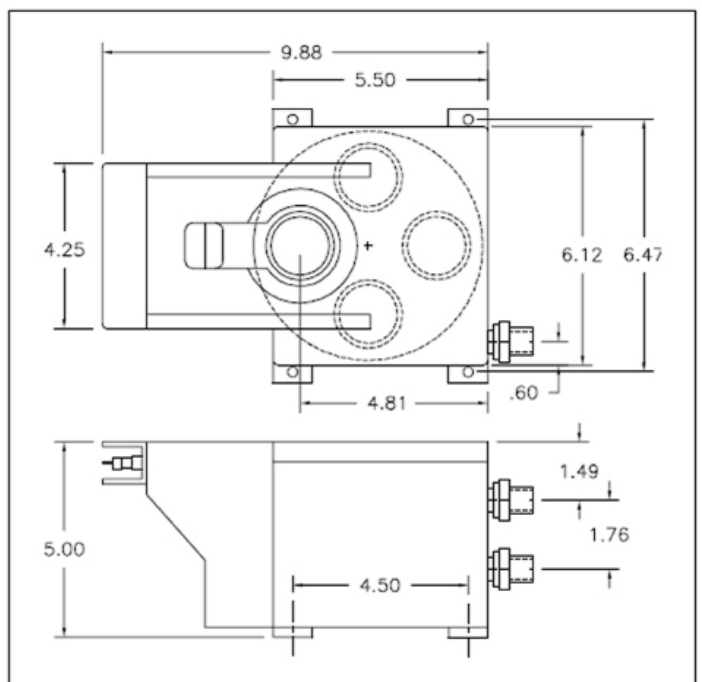

FIG. 1 - HCR Rotary E-Gun dimensional outline

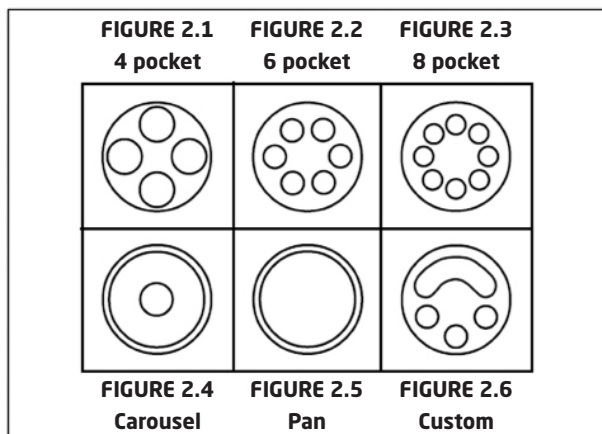
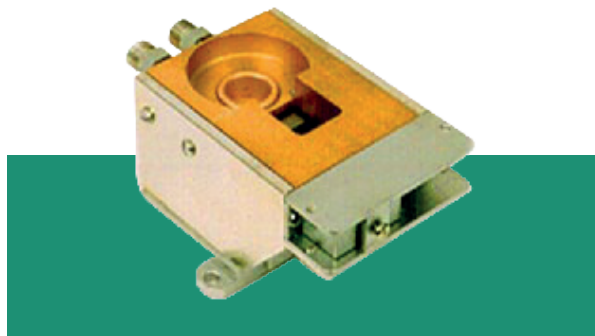

FIG. 2 - Crucible illustration, top view

RC SERIES, RESEARCH CAPACITY ELECTRON BEAM EVAPORATION SOURCES

MULTIPLE CRUCIBLE ROTARY 3 KW E-GUN™

3 kW E-Gun Research Capacity series provides enhanced beam stability and efficient XY sweep with full crucible coverage. Plug-in emitter assemblies and sweep coil assemblies make the sources easier to service. The line includes a full spectrum of power supplies, sweep controllers and accessories, including crucible liners.



FEATURES

- True XY sweep with full crucible coverage
- Sweep coils included with source
- Enhanced beam culmination
- Plug-in emitter module
- Enhanced high-stability cooling
- Cross-contamination shielding
- Rugged design
- Interchangeable crucibles
- High Vacuum compatible

SPECIFICATIONS

Operating pressure	Low 10 ⁻⁵ mbar is desirable for best operation
Beam voltage	4000 V DC
Beam current	0-750 mA continuously variable
Maximum power	3 kW
Cooling water	6 l/mn
Pressure differential	2 bars minimum
Maximum bakeout temperature	120°C
Crucible volume	2.24 cc x 4, 6 or 8 crucibles

ORDERING INFORMATION

DESCRIPTION	P/N
Multiple Crucible E-Gun source with sweep coils, rotary 4-crucible	RCR0304-SD / -BD*
Multiple Crucible E-Gun source with sweep coils, rotary 6-crucible	RCR0306-SD / -BD*
Multiple Crucible E-Gun source with sweep coils, rotary 8-crucible	RCR0308-SD / -BD*

*SD denotes side drive, BD denotes bottom drive

3 KW ROD-FED E-GUN™

The operation of the 3 kW rod-fed E-Gun is unique. The evaporant source material, in the form of a rod up to 3/8" in diameter, is fed continuously into the crucible using an external linear feedthrough. The design protects the emitter from damage and shorting during installation and service. The improved water-cooling system enhances heat transfer, which increases rate stability and prevents damage to the e-beam source.

The Rod-Fed E-Gun is designed for easy installation into MBE systems.

FEATURES

- 3 kW E-Gun source
- Fits into a CF 63 type port
- Rod-fed material for continuous evaporation
- Completely shielded emitter
- Fully UHV compatible

ORDERING INFORMATION

DESCRIPTION	P/N
Rod-Fed E-gun only	RF0303-25
Rod-Fed e-gun with all utility, electrical and mechanical feedthroughs mounted on a 63 CF type flange	RF0303-25/SK

SPECIFICATIONS

Operating pressure	Low 10 ⁻⁵ mbar is desirable for best operation
Beam voltage	4000 V DC
Beam current	0-750 mA continuously variable
Maximum power	3 kW
Cooling water	4 l/mn
Pressure differential	2 bars minimum
Maximum bakeout temperature	230°C
Crucible volume	1/4" (6.35 mm) diameter -or- 3/8" (9.53 mm) diameter rod; 3" standard length
e-Gun size	2.25" diameter x 2.95" height



E-GUN POWER SUPPLIES

HIGH FREQUENCY SWITCHING

The e-Gun power supply is a high performance switch mode power supply. It operates above 20 kHz and uses the most reliable IGBT switches available. The SEB power supply is designed to optimize e-Gun performance and maximize power supply reliability in any production coating application.

CONSERVATIVE ELECTRICAL DESIGN

Power supplies are conservatively designed. Each power supply is designed to operate continuously and reliably at full power and maximum load ratings, with enough head room to accommodate the most dynamic operating characteristics and brutal operating conditions. Every power supply is dynamically tested, including repetitive arc testing, prior to shipment.

FILCHEK™ FILAMENT CHECK

FilChek is an exclusive feature included on every power supply. FilChek is a momentary switch mounted on the power supply front panel. It provides a quick, convenient, and simple test of the e-Gun evaporation source filament. Not simply a continuity check, FilChek supplies a measured, dynamic load through the filament to provide a reliable, easy-to-use, and true test of filament condition.

DYNAMIC ARC SUPPRESSION

Power supplies incorporate advanced arc detection and suppression circuits to insure maximum performance with any evaporant material.

MULTIPLE OUTPUT

Power supply is designed to power and operate up to three e-Gun evaporation sources either sequentially or simultaneously. Multiple output taps are provided at the rear of each power supply. Each power supply is shipped with one e-Gun control module as standard equipment. An additional "plug-in" e-Gun control module is required for each additional e-Gun you may wish to operate.

LOW STORED ENERGY

Power supplies maintain excellent output regulation while minimizing the amount of energy available during arc events. This permits fast arc recovery and greatly enhances e-Gun operation, performance, and reliability.

COMPATIBLE WITH OTHER EVAPORATION SOURCES

The power supplies can be used with all our e-Gun evaporation sources as well as evaporation sources from other manufacturers.



Power supply

	SVA-03	SVA-06	SVA-012
Power	3 kW	6 kW	12 kW
Input power	208/240 V - 50/60 Hz - 1P 30 A	Standard: 180-264 V - 50/60 Hz - 3P 25 A Optional: 360-528 V - 50/60 Hz - 3P 12.5 A 180-264 V - 50/60 Hz - 1P 57 A	Standard: 180-264 V - 50/60 Hz - 3P 50 A Optional: 360-528 V - 50/60 Hz - 3P 25 A
Output voltage	0 to 5 kV	0 to 8 kV	0 to 10 kV DC
Output current	0 to 600 mA	0 to 600 mA	0 to 600 mA
Cooling	Air cooling	Air cooling	Air cooling
Panel space	19" W. x 10.5" H x 18" D	19" W. x 5.22" H x 22.6" D	19" W. x 10.5" H x 22.7" D
Weight	< 45 kg	< 45 kg	< 45 kg

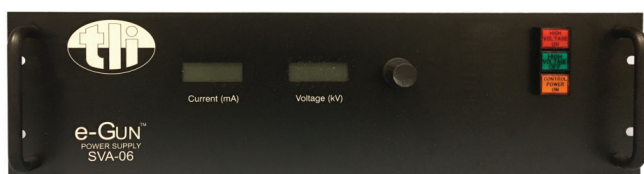

6 kW power supply



Indexer controller



X/Y/Z sweep controller

Electron & Ion-Gun Parts

ELECTRON-GUN PARTS

Neyco provides all replacement parts for Thermionics, Balzers, and other E-guns, such as emitters, emitters parts, filaments, insulators, crucibles covers...

Many references available from stock.



E-Beam gun insulators

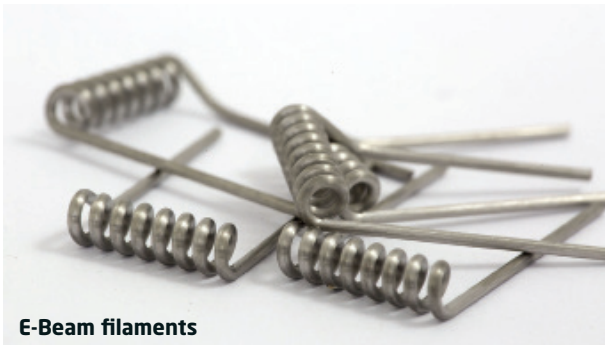

E-Beam filaments

STANDARD MULTI- POCKET EMITTER

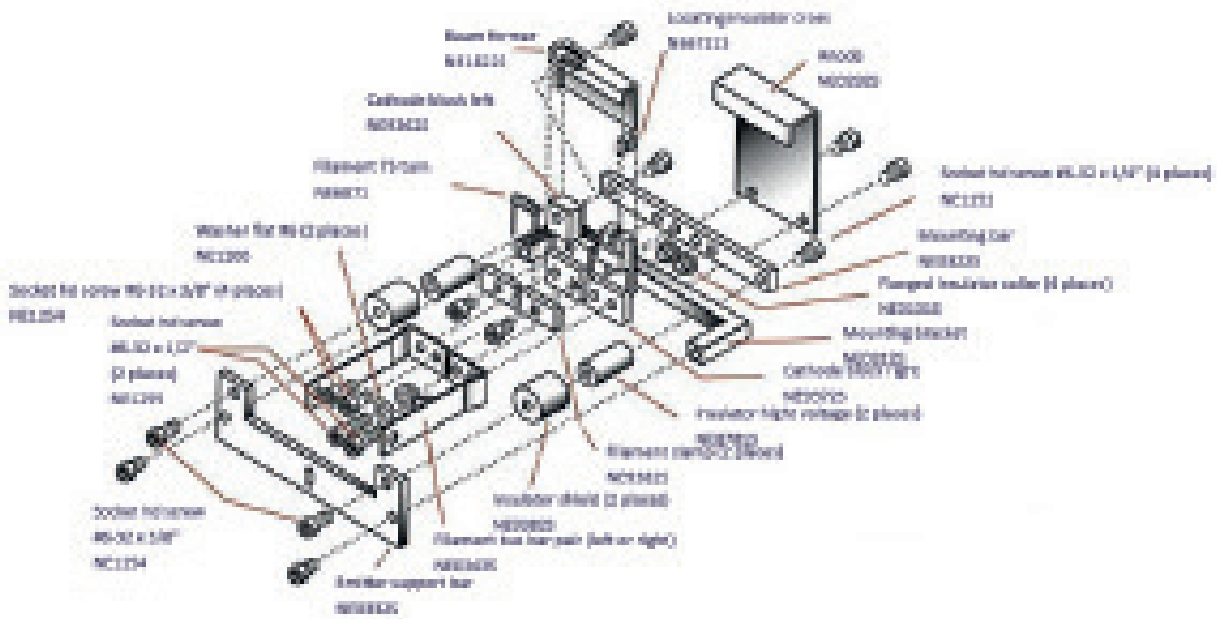

Other parts are available on request, as:

- Permanent magnets
- Coil assemblies
- Sources crucibles
- Crucible covers

Emitter parts kits can be interchanged on request.

ION-GUN PARTS

Neyco provides all spare parts for MARK I and MARK II ion-guns.

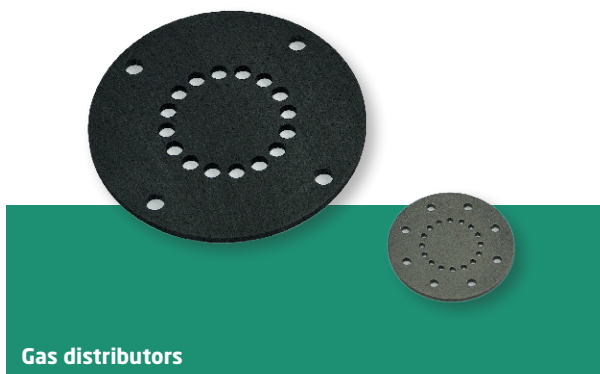

Gas distributors



MARK II filament

FILAMENTS

P/N NEYCO	TYPE	PACKING
EB-2S	MARK II	10 pcs
EB-1	MARK I	10 pcs

GAS DISTRIBUTORS

P/N NEYCO	TYPE	MATTER	PACKING
NE18005-G	MARK I	Graphite	Unit
NE18005-S	MARK I	Stainless	Unit
NE18005-T	MARK I	Titanium	Unit
NEDIM2C	MARK II	Graphite	Unit
NEDIM2I	MARK II	Stainless	Unit
NEDIM2T	MARK II	Titanium	Unit
NE28099-G	MARK III	Graphite	Unit
NE28099-S	MARK III	Stainless	Unit

ANODES

P/N NEYCO	TYPE	MATTER	PACKING
B18003-1	MARK I	Graphite	Unit
B18003-2	MARK I	Stainless	Unit
B18933-1	MARK II	Graphite	Unit
B18933-2	MARK II	Stainless	Unit

CATHODE TIPS & KEEPERS

P/N NEYCO	TYPE	PACKING
B17968SP	MARK II cathode tip	Unit
A17973	MARK II Keeper	Unit

INSULATORS

P/N NEYCO	TYPE	PACKING
NE1032M	MARK I, II, III	Unit
NE1451001	MARK I (ruby sapphire)	Unit
NEC035	Male Insulator IonTech	Unit
NEC036	Female Insulator IonTech	Unit
NEC037	Male Insulator IonTech	Unit
NE06MS	MARK I, II	Unit
NE2520F	MARK I, II, III	Unit

Other parts on request.

Thin Film Deposition System

The **MAGEVA** thin film deposition system is a flexible tool, which operates, **ALL IN ONE**, either in thermal evaporation or sputter deposition, or in combination of both.

MAGEVA

Compact, for a better utilization in clean room and laboratory space, the frame is equipped with wheels for quick and effortless transportation.

The stainless steel chamber, fitted with turbo and rotary pumps, allows user to change process in less than 10 minutes.

MAGEVA pumps down very quickly to high vacuum (10^{-6} mbar range).

The system is available in three versions, depending on the size of the magnetron sputtering cathode:

- MAGEVA-50
- MAGEVA-75
- MAGEVA-100

MAGEVA is suitable for both research and small lot production requirements

SAFE AND CE

Automated interlocks ensure safe operation at all times; an emergency stop button protect both operator and machine. All power distribution and system controls are enclosed in the cabinet.

MAGEVA carries the CE conformity marking.



FEATURES

- SS chamber ISO 250 x 250 mm height
- Quick-access door and viewport
- Sample holder 100 mm x 100 mm
- Gas entry with fine adjustment valve for sputtering
- Mass flow controller (Optional)
- Turbo pump 240 l/s
- Primary rotary vane pump 17 m³/h
- Primary dry pump (Optional)
- Manual gate valve ISO 100
- 2" cathode magnetron for MAGEVA-50
- 3" cathode magnetron for MAGEVA-75
- 4" cathode magnetron for MAGEVA-100
- Thermal evaporator (filament and evaporation boat holder)
- Full range gauge (10⁻⁹ to 1200 mbar)
- 6 MHz quartz sensor probe with Q-Pod
- DC power supply 1.5 kW for sputtering
- DC power supply 10 V 330 A for thermal effect
- Total dimensions (with frame) 110 cm L x 70 cm I x 140 cm H
- Weight: 90 kg



Thin Film Deposition Services

Neyco offers thin films depositions, upon your specifications on various substrates.

 See Section J -Silicon Wafers in this catalogue for additional services such as Thermal Oxidation, and Nitration.

THIN FILM DEPOSITION ON REQUEST

Our factory offers 850 m² of clean rooms equipped with 12 coating systems (sputtering, electron gun, ion assistance, and thermal evaporation).

Chambers dimensions: diameter 300 to 1400 mm.

From single substrate to large batches, on many types of materials: glass, Silicon wafer, single crystals, Stainless Steel, Nickel, Copper, Aluminum, ...

In-situ and ex-situ characterization tools: transmission, thickness, reflection, adherence

We are able to develop the thin films you need, upon your specifications.

French government accreditation «Crédit Impôt Recherche» (laboratory).

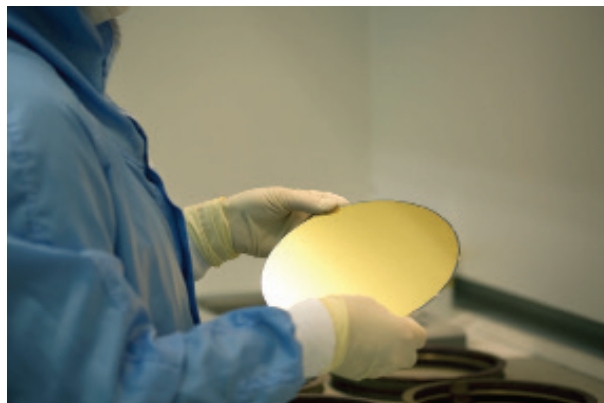

OPTICAL THIN FILMS

Wide range of optical coatings, obtained by EB evaporation. Some of highlights (spectral range from 0.3 to 15 μ):

- Antireflect (AR)
- Mirrors : with metal, dielectric, high reflexion > 99.5%
- Black coating (R < 3% in visible range)
- Dichroic filters, high-pass, low-pass...
- Optical filters

DECORATIVE THIN FILMS

Decorative coatings are obtained by vacuum evaporation or sputtering:

- Metal based (Al, Au, Ag, Ni...)
- Colors: (co-deposition, oxides...)
- Intense black

OTHER THIN FILMS

- Resistive and conductive layers
- Metallization for soldering applications
- Electronical contacts
- Thermal oxydation, nitration
- Photolithography
- ...etc

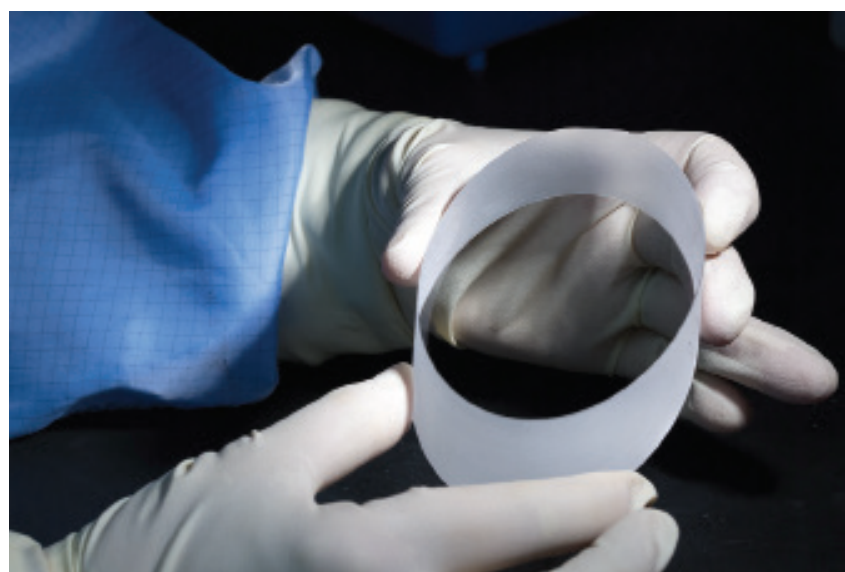

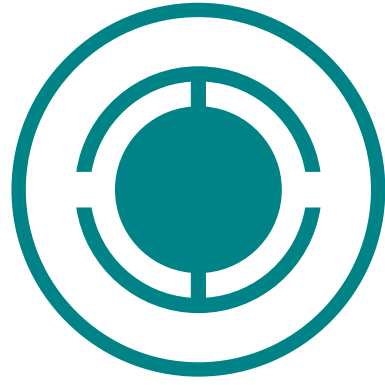

MATERIALS THICKNESS MEASUREMENT

- Front Load Single/Dual Sensors..... N 04
- Cool Drawer Single/Dual Sensors N 06
- Sputtering Sensor N 08
- CrystalSix® Sensor N 09
- Crystal 12® Sensor..... N 10
- Sensor Crystal for Quartz Microbalance..... N 12
- Q-pod N 13
- XTC/3 Series Thin Film Deposition Controllers..... N 14
- SQC-310 Series Thin Film Deposition Controllers . N 15
- SQM-160 Multi-Film Rate/Thickness Monitors N 16
- Density and Acoustic Impedance Values..... N 17

Quartz microbalance (QCM) are used to measure, in situ and in real time, the thickness of thin films during vacuum deposition.

PRINCIPLE OF USE

The measurement is based on the modification of oscillation frequency of the piezoelectric crystal due to mass overload. Thus, when a material thin film is deposited on the surface of a quartz crystal, its resonance frequency varies in a proportional way of the deposited layer mass/weight. We mainly use 5 MHz or 6 MHz AT-cut quartz. The 6 MHz quartz are dedicated to most recent deposition systems while the 5 MHz are typically used in BALZERS and equivalent evaporators.

The quartz probe has to be installed inside the vacuum chamber, close enough to the substrate where the deposition will be performed (refer to the picture below). Knowing the density of the layer, the thickness of the layer is then calculated in real time. Initial measurements as micro-weight (or nano-weight for very thin layers) or thickness on the substrate allow to pre-calibrate the system.



Neyco supplies two types of measurement chains by microbalance.

The standard one is Quartz Microbalance with Oscillator, including :

- 1 water-cooled quartz probe
- 1 watercooling feedthrough with 2 tubes + 1 coaxial cable to connect the quartz to the external oscillator
- 1 electrical oscillator mounted as close as possible to the vacuum feedthrough (thus to the quartz)
- 1 controller or monitor

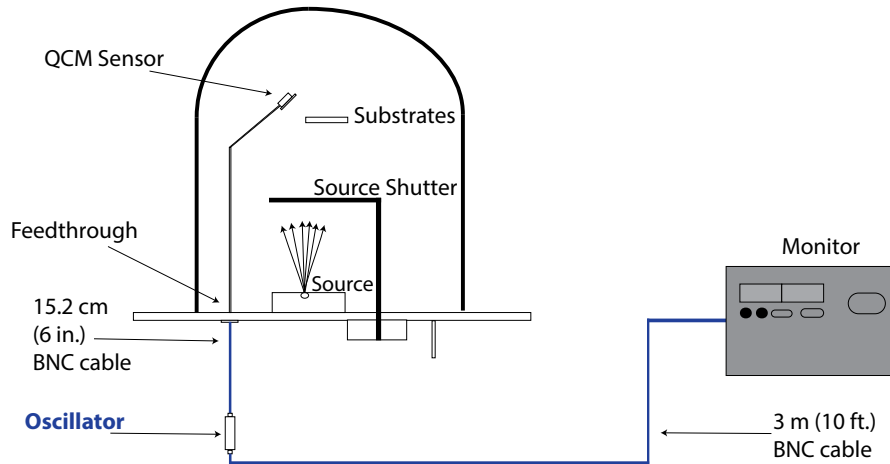

The second system is the Quartz Microbalance (QCM) with a Q-pod (also known as QPOD and STM-2):

The Q-pod replaces both the oscillator and the monitor, and allows the data acquisition directly with the dedicated software.

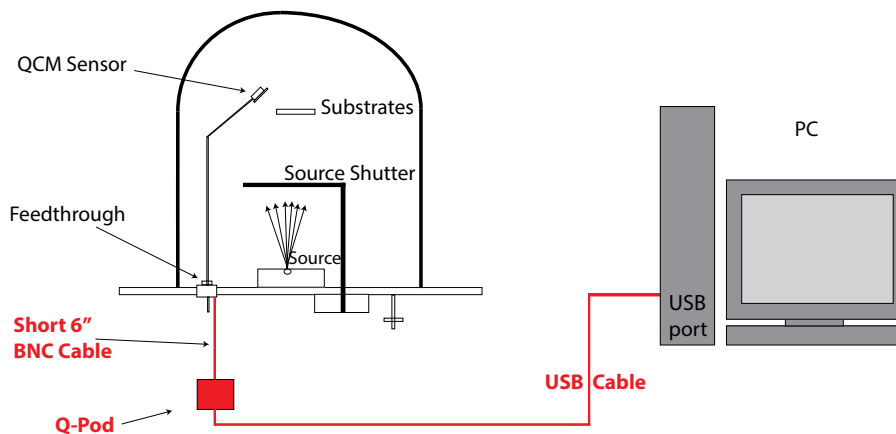

Front Load Single/Dual Sensors

Front Load Single/Dual crystal sensors offer proven reliability and durability and have an excellent thermal stability. The front load design allows for easy insertion of the crystal holder in applications lacking sufficient room for side insertion.

Assembled mechanically rather than soldered, parts can be replaced conveniently in the field, if necessary. Sensors can be ordered individually or in a sensor/feedthrough combination that can be either welded or assembled with compression fittings.



Front load single sensor

FRONT LOAD SINGLE SENSOR CONFIGURATION

Two sensor configurations are offered: the standard version and the right angle (compact) version. The standard version is designed for installation from the side or bottom of the chamber having the cooling tubes parallel to the crystal face. The right angle version is designed for installation through the top of the vacuum system having the water cooling tubes perpendicular to the crystal face. Optionally, sensors can be ordered with a pneumatically driven crystal shutter to protect the crystal during source warm up, when not used during deposition of an alternate material, or to extend crystal life when used in sequential acquisition. The shutter is designed to flip down allowing easy crystal replacement.

FRONT LOAD DUAL SENSOR CONFIGURATION

The Front Load Dual Sensor is available in a standard mount configuration where the water tubes are parallel to the crystal face. A pneumatically driven crystal shutter comes standard to protect the back-up crystal, while the primary crystal monitors the deposition rate. The shutter is designed to flip down allowing easy crystal replacement.

For both Single and Dual Sensors, the exposed crystal electrode is fully grounded to effectively eliminate problems due to RF interference.

FEEDTHROUGHS

Neyco offers all types of feedthroughs: 1 inch bolt feedthrough, 2¾ inch (CF40) ConFlat® flange feedthrough and KF40 feedthroughs for the most popular.

FEEDTHROUGH CONNECTION

Front Load Single sensors can be ordered in combination with a feedthrough. The sensor / feedthrough connection can be either welded or made with compression fittings.

Compression fittings allow for easy adjustability without the need for brazing or welding. The feedthrough can be moved along the length of the tubes allowing the length inside the vacuum systems to be adjusted over a range of 20.3 to 121.9 cm (8 to 48 inches). Once the desired length is determined, the compression fittings allow for a finger tight tube seal. Alternately, a welded connection may be chosen. If a welded connection is desired, a sensor length specification form, must be completed prior to ordering and submitted with the order.

ADVANTAGES

- Front load crystal holder
- Easy installation
- Adjustable length if ordered with compression fittings
- Sensor/Feedthrough combinations available welded to customer specified lengths
- No brazing required if ordered with compression fittings or welded to feedthrough

SPECIFICATIONS

Maximum bakeout temperature with no water	130°C
Maximum operating isothermal environment temperature with minimum water flow	up to 400°C (according configurations)
Standard single sensor size	27 mm x 61.47 mm x 17.53 cm
Right angle single sensor size	28.19 mm x 26.92 mm x 26.92 mm
Dual sensor size	39.12 mm x 82.04 mm x 49.54 mm
Crystal exchange	Front loading; self-contained package for ease of exchange
Mounting	Two #4-40 tapped holes on the back of the sensor body
Crystal	0.550" (13.97 mm) diameter, 5 MHz or 6 MHz

Cool Drawer Single/Dual Sensors

The Cool Drawer™ Single/Dual Sensors allow crystal installation into the sensor from the side, convenient for systems with insufficient room for front load crystal installation.

The Cool Drawer™ Dual Sensor is designed for use in critical processes where it is desirable to have a second crystal in the vacuum chamber.

The sensors employ the Cool Drawer Crystal Holder which is thermally shielded by the water-cooled housing insuring excellent crystal performance.

ADVANTAGES

- No internal cables
- Cool Drawer crystal holder
- Easy installation
- Bakeable if ordered with welded CF40 flange
- Adjustable length if ordered with compression fittings
- No brazing required if ordered with compression fittings
- Sensor/Feedthrough combinations available welded to customer specified lengths

Available with:

- CF40 feedthrough
- 1" (2.54 cm) bolt feedthrough

SENSOR CONFIGURATIONS

Two sensor configurations are offered: the standard version and the right angle version. The standard version is designed for installation from the side or bottom of the



Single sensors with 2.54 cm (1") bolt feedthrough

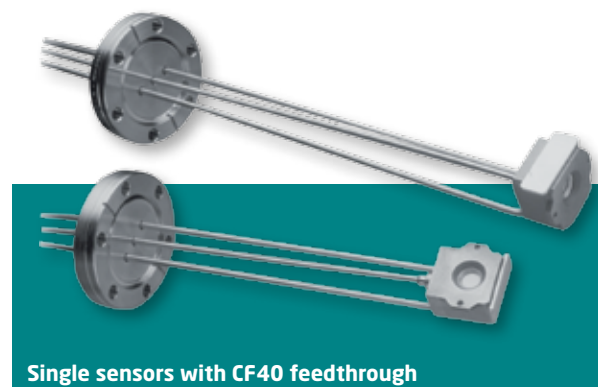

Single sensors with CF40 feedthrough

chamber and the cooling tubes and the crystal face are parallel. The right angle version is designed for installation through the top of the vacuum system and the water cooling tubes are perpendicular to the crystal face.

Single Sensor: both versions are available with or without a crystal shutter.

Dual Sensor: the sensor with the CF40 flange is pre-installed in a special two piece CF40 feedthrough. This allows the sensor head to be rotated independently of the flange and circumvents the dimensional limitations of the CF flange. Available with crystal shutter.



Cool Drawer™ crystal holder

Compression fittings allow the easy adjustability without the need for brazing or welding. The feedthrough can be moved along the length of the tubes allowing the length inside the vacuum system to be adjusted over a range of 10 to 66 cm (4" to 26").

Once the desired length is determined, the compression fittings allow for a finger tight tube seal.

When selected with the welded CF40, the sensor is designed for high temperature processes where reliability is critical. Constructed of stainless steel and ceramic materials it is suitable for applications requiring high temperature bakeout (see specifications).

FEEDTHROUGH CONNECTIONS

Cool Drawer single sensors must be ordered in combination with a feedthrough. The sensor / feedthrough connection can be either welded or made with compression fittings.

SPECIFICATIONS

Temperature (1 inch bolt)	Operational environment to 300°C with water cooling or 165°C without
Temperature (CF 40)	Operational environment to 450°C with water cooling or 165°C without
Crystal	Industry standard 0.550" (13.97 mm) diameter, 5 MHz or 6 MHz

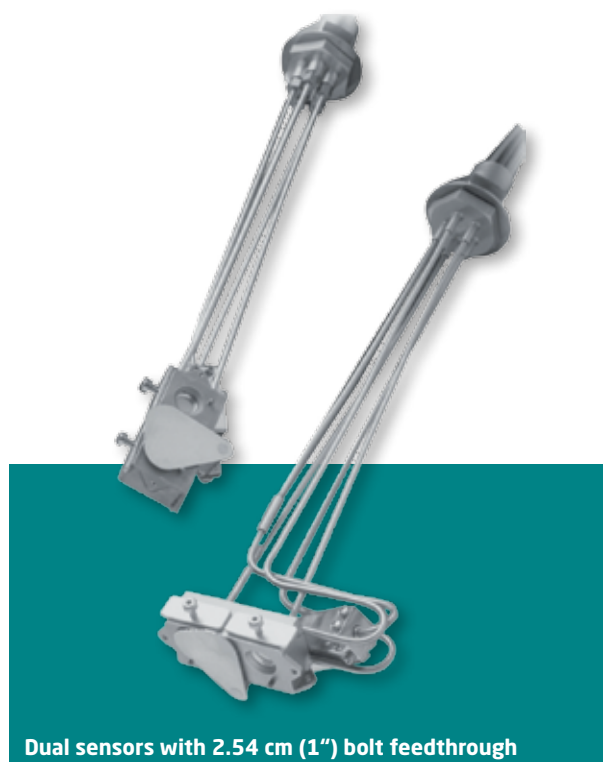

Dual sensors with 2.54 cm (1") bolt feedthrough



Dual sensors with CF40 feedthrough

Sputtering Sensor

The Sputtering Sensor is specifically designed for use in any sputtering process. The sensor body and cooling tubes are Gold plated Beryllium Copper for maximum cooling efficiency in the sputtering environment.

A magnet built into the sensor head reduces excessive heating by energetic free electrons in sputtering systems by deflecting them with the external magnetic field.

The rear loading crystal holder design allows easy crystal replacement without having to remove the sensor head from the system.

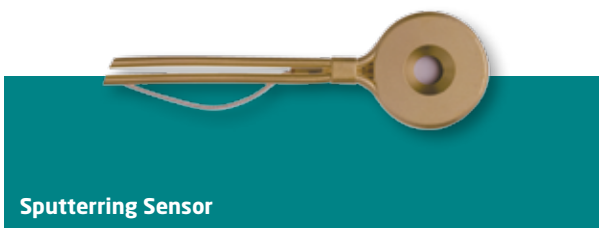

Sputtering Sensor

FEEDTHROUGHS

Neyco offers two types of feedthroughs, either a 1 inch bolt and Ultra-Torr (compressing fitting) terminations or a CF40 welded terminations.

ADVANTAGES

- Gold plated Beryllium Copper sensor body and cooling tubes for maximum cooling efficiency
- Magnet to deflect free electrons away from the monitor crystal
- Easy installation with bendable water tubes allowing flexibility in sensor placement
- Rear load crystal insertion for easy crystal replacement

SPECIFICATIONS

Maximum bakeout temperature with no water	105°C
Maximum operating isothermal environment temperature with minimum water flow	up to 400°C
Size (maximum envelope)	34.55 mm OD x 17.5 mm
Material	Au plated Be-Cu
Crystal exchange	Rear-loading
Crystal	0.550" (13.97 mm) diameter, 5 MHz or 6 MHz

CrystalSix® Sensor

The CrystalSix® Sensor is critical for long processes demanding continuous rate control. Whether an OLED, MBE, solar, long optical coating, or other processes having an extended period between chamber venting, the CrystalSix® sensor offers the security of 6 quartz monitor crystals in one sensor head. When used with a thin film controller, the CrystalSix® automatically rotates a new crystal into position whenever the current crystal fails or becomes unstable. Crystals are automatically replaced without interrupting your process for continued deposition rate monitoring.

Crystal indexing is accomplished with a pneumatically driven mechanism. This pneumatically driven motor provides better crystal thermal stability than competitive units using expensive in-vacuum, heat generating, electric motors. 1/8" water cooling tubes keep the sensor head thermally stable and allow flexibility in sensor placement.

When used with certain thin film controllers, the sensor provides position feedback so specific positions can be used with specific materials.

ADVANTAGES

- Hold six crystals with robust, automatic switching to maximize process uptime
- Stable crystal temperature, because crystal switching is pneumatically-driven
- 1/8" (3.2 mm) tubes maintain thermal stability and allow flexibility in sensor placement
- Optional crystal shutter available



CrystalSix® Sensor

SPECIFICATIONS

Maximum bakeout temperature without water	130°C
Maximum operating isothermal environment temperature with minimum water flow	up to 400°C
Size (maximum envelope)	97mm OD x 51 mm
Material	SS 304
Crystal exchange	Rear-loading
Crystal	0.550" (13.97 mm) diameter, 5 MHz or 6 MHz

Crystal 12® Sensor

The Crystal 12® sensor is critical for long processes demanding continuous rate control. Whether an OLED, MBE, Solar or other process having an extended period between venting, the Crystal 12® sensor offers the security of 12 quartz monitor crystals in one sensor head. When used with Cygnus 2, IC6, XTC/3M, XTC/3S, SQC-310C, the Crystal 12® automatically rotates a new crystal into position whenever the current crystal fails or become unstable. Crystals are automatically replaced without interrupting your process for continuous deposition rate monitoring. To further minimize downtime, crystals can be preloaded into a second optional carousel, which can then be quickly and easily exchanged with the carousel containing the exhausted crystals, minimizing the time the system is open.

Crystal indexing is accomplished with a pneumatically driven mechanism. This pneumatic drive provides better thermal stability than competitive units using expensive in-vacuum, heat generating, electric motors. 1/8" (3.2 mm) water cooling tubes keep the sensor head thermally stable and allow flexibility in sensor placement.

When used with certain thin film controllers, the sensor provides position feedback so specific positions can be used with specific materials.



Crystal 12® Sensor



Crystal 12® Sensor

ADVANTAGES

- Hold 12 crystals with robust, automatic switching to maximize process uptime
- Easy-to-remove carousel allows fast replacement of all 12 crystals
- Stable crystal temperature, because crystal switching is pneumatically-driven
- Accommodate metric hardware
- 1/8" (3.2 mm) tubes maintain thermal stability and allow flexibility in sensor placement
- Easy-to-remove front deposition shield protects the crystals and carousel from material accumulation, minimizing the need to remove entire sensor for maintenance
- Optional mounting-post kit can be user-modified to accommodate metric hardware
- Optional crystal shutter available

SPECIFICATIONS

Maximum bakeout temperature without water	130°C
Maximum operating isothermal environment temperature with minimum water flow	300°C
Size (maximum envelope)	102 mm OD x 84 mm
Material	SS 304
Crystal exchange	Front-loading
Mounting	Six #4-40 tapped holes on the back of the sensor body, six #4-40 tapped holes outside circumference. Three #6-32 tapped holes with optional mounting kit
Crystal	0.550" (13.97 mm) diameter, 5 MHz or 6 MHz

Sensor Crystals for Quartz Microbalance

The quality and longevity of a crystal affect not only the accuracy of rate and thickness measurements, but also the successful completion of the process being controlled. Our quartz crystals offer proven quality and reliability with successful process runs with a wide range of materials, applications and industries.

The 6 MHz and the 5 MHz crystals are available in Gold, Silver or alloy electrodes.

We recommend Gold crystals for most applications. However, Silver crystals will provide superior performance in processes with high heat loads, such as sputtering. They may also improve the deposition of oxides. And alloy crystals are recommended for optical coating with dielectric materials and for semiconductor processes with high-stress materials.



P/N	NOMINAL FREQ.	MATERIAL	DIAMETER (mm)	TYPE	PACKING
NE104B5	5 MHz	Au	13.97	AT-cut	20 pcs
AGSA5	5 MHz	Ag	13.97	AT-cut	20 pcs
AUDA598B	6 MHz	Au	13.97	AT-cut	10 pcs
AUDA6B	6 MHz	Au	13.97	AT-cut	10 pcs
7501002-G10	6 MHz	Alloy	13.97	AT-cut	10 pcs

Others frequencies and packings are available on request.

Q-pod

THE CAPABILITIES OF A TRADITIONAL QCM AT A FRACTION OF THE SIZE AND COST

The INFICON Q-pod™ (also called STM2) transducer is a small, inexpensive, accurate way to measure thin film deposition rate and thickness.

Connect the Q-pod BNC connector to the signal cable from a QCM sensor. On the other side, a standard USB cable connects to your PC. No external oscillator or power source is required. Load the free Q-pod software on your PC. Q-pod software displays rate, thickness, frequency, crystal life, and a graph of rate versus time, for up to 8 Q-pods simultaneously.



Sensor	Non-shuttered single QCM sensor
Frequency range	5.0 to 6.0 MHz
Frequency resolution	0.03 Hz at 6 MHz
Frequency accuracy	0.002 %
Frequency stability	±2 ppm total, over 0°C to 50°C
Input	BNC
Interface & power	USB, v2.0 or later
Size	114 x 75 x 25 mm
Weight	57 g
Software included	Provides display and setup of all operating parameters

XTC/3 Series Thin Film Deposition Controllers



Thin film deposition controller for single and multiple-layer processes.

The XTC/3 with patented ModeLock provides proven prevention for consistent quality. With the XTC/3 Thin Film Deposition Controller, you get highly accurate control of deposition rate and thickness, the capacity for virtually any number of layers, easy installation, and extremely high reliability to ensure productivity.

FEATURES

- Available in single-layer and multiple-layer models
- Patented ModeLock technology prevents film thickness errors caused by mode-hopping
- Supports INFICON Crystal 12®, CrystalSix® and dual sensor automatic crystal switching for maximum productivity
- XTC/3M multiple-layer model supports up to 99 processes, 999 layers, 32 films, 2 sensors and two sources
- XTC/3S single-layer model supports up to 9 films, 2 sensors and two sources
- Easy-to-read TFT LCD graphics displays
- Films and processes can be assigned unique, descriptive names for easy retrieval
- Ethernet connection available
- Free-standing (no computer necessary) or optional Windows® software for PC operation

SQC-310 Series Thin Film Deposition Controllers

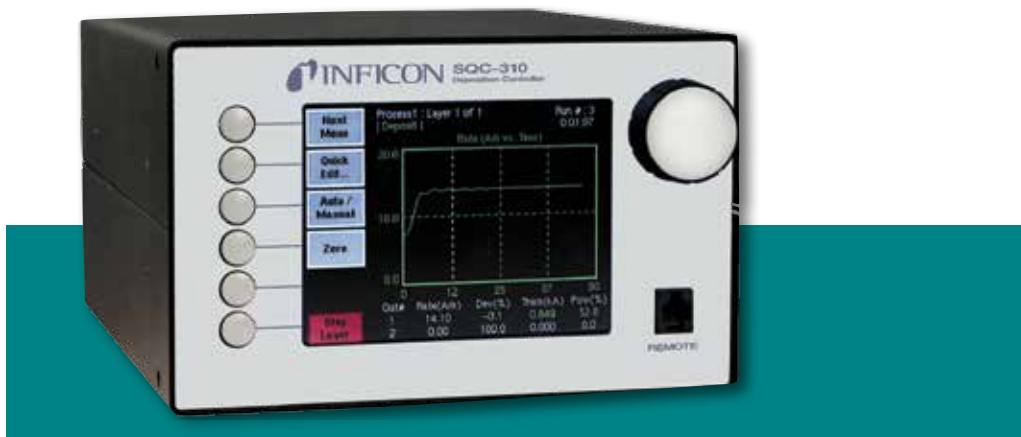

With advanced electronics and an improved display, the INFICON SQC-310 Series gives you features not found on competitors' thin film controllers. And you can choose the ideal model for your application: sequential deposition (SQC-310) or co-deposition (SQC-310C).

FEATURES

- Bright, color LCD display
- Standard RS-232 and USB (with Ethernet option)
- Easy setup and operation with a "Quick Setup" Menu, 6 context-sensitive push buttons, and convenient parameter setting knob
- Windows® program for developing, testing, and downloading processes, and for logging instrument data to your PC for process analysis and quality control
- Accurate process control, especially for low deposition rates, with ± 0.03 Hz resolution at 10 readings/second, and with ± 2 ppm frequency stability over 0°C to 50°C
- Storage capacity for up to 100 processes, 1000 layers, 50 films
- Monitoring of source material with a single sensor or with multiple sensors to provide accurate source distribution monitoring

SQM-160

Multi-Film Rate/Thickness Monitors



The SQM-160 uses proven INFICON quartz crystal sensor technology to measure rate and thickness in thin film deposition processes. Two sensor inputs are standard and four additional sensor inputs are optional. Two recorder outputs provide analog rate and thickness signals.

Sensor inputs can be assigned to different materials, averaged for accurate deposition control in large systems, or configured for a dual sensor. The rate sampling mode allows a shuttered sensor to extend sensor life in high rate processes. Rate displays of 0.1 Å/s or 0.01 Å/s are user selectable. In addition, Frequency or Mass displays can be selected. Four relay outputs allow the SQM-160 to control source or sensor shutters, signal time and thickness setpoints, and signal crystal failure. Digital inputs allow external signals to start/ stop and zero readings.

The SQM-160 comes with an RS-232 port and Windows® software that allows instrument setup from your computer. The software can be used to set and store all parameters, operate the instrument, and save process data in an Excel® file format. USB or Ethernet options add to the communications flexibility.

Two menus control instrument setup for the 99 stored films.

Standard frequency resolution is 0.12 Hz at four readings per second. The high accuracy SQM-160H option increases resolution to 0.03 Hz at 10 readings per second. Temperature stability is 2ppm over the entire operating range.

Density and Acoustic Impedance Values

We have compiled a list of some popular materials used in the vacuum industry and provided their material density and acoustic impedance values. This table has been compiled in combination with the PHYSICS HANDBOOK and actual customer experience. Although we have made every effort to test them, Neyco cannot guarantee

the accuracy of these values.

The Z factor found on most controllers and monitors is calculated with the ratio of the acoustic impedance of crystal quartz and the selected materials. ie: Z factor for SiO₂ = 1

MATERIAL NAME	SYMBOL	DENSITY gm/cm ³	ACOUSTIC x10 ⁵ gm/cm ² sec
Aluminum	Al	2.700	8.170
Aluminum Antimonide	AlSb	4.360	11.884
Aluminum Oxide	Al ₂ O ₃	3.970	26.280
Antimony	Sb	6.620	11.490
Arsenic	As	5.730	9.140
Barium	Ba	3.500	4.200
Barium Fluoride	BaF ₂	4.886	11.135
Barium Nitrate	BaN ₂ O ₆	3.244	7.002
Barium Titanate (Cubic)	BaTiO ₃	6.035	21.432
Barium Titanate (Tetr)	BaTiO ₃	5.999	19.030
Beryllium	Be	1.850	16.260
Bismuth	Bi	9.800	11.180
Boron	B	2.540	22.700
Cadmium	Cd	8.640	12.950
Cadmium Sulfide	CdS	4.830	8.660
Cadmium Telluride	CdTe	5.850	9.010
Calcium	Ca	1.550	3.370
Calcium Fluoride	CaF ₂	3.180	11.390
Calcium Sulfate	CaSO ₄	2.962	9.246
Carbon (Diamond)	C	3.520	40.140
Carbon (Graphite)	C	2.250	2.710
Cesium Bromide	CsBr	4.456	6.262
Cesium Chloride	CsCl	3.988	6.312

MATERIAL NAME	SYMBOL	DENSITY gm/cm ³	ACOUSTIC x10 ⁵ gm/cm ² sec
Cesium Iodide	CsI	4.516	5.726
Cesium Sulfate	Cs ₂ SO ₄	4.243	7.285
Chromium	Cr	7.200	28.950
Cobalt	Co	8.710	25.740
Cobalt Oxide	CoO	6.440	21.432
Copper	Cu	8.930	20.210
Copper (I) Sulfide (alpha)	Cu ₂ S	5.600	12.800
Copper (I) Sulfide (beta)	Cu ₂ S	5.800	13.180
Copper (II) Sulfide	CuS	4.600	10.770
Dysprosium	Dy	8.540	14.720
Erbium	Er	9.050	11.930
Gadolinium	Gd	7.890	13.180
Gallium	Ga	5.930	14.890
Gallium Arsenide	GaAs	5.310	5.550
Germanium	Ge	5.350	17.110
Gold	Au	19.300	23.180
Hafnium	Hf	13.090	24.530
Holmium	Ho	8.800	15.200
Indium	In	7.300	10.500
Indium Antimonide	InSb	5.760	11.480
Iridium	Ir	22.400	68.450
Iron	Fe	7.860	25.300
Lanthanum	La	6.170	9.590
Lead	Pb	11.300	7.810
Lead Fluoride	PbF ₂	8.240	13.359
Lead Sulfide	PbS	7.500	15.600
Lead Telluride	PbTe	8.160	13.564
Lithium	Li	0.530	1.500
Lithium Bromide	LiBr	3.470	7.179
Lithium Fluoride	LiF	2.640	11.410
Lithium Niobate	LiNbO ₃	4.700	19.071
Magnesium	Mg	1.740	5.480
Magnesium Fluoride	MgF ₂	3.000	13.860
Magnesium Oxide	MgO	3.580	21.480
Manganese	Mn	7.200	23.420
Manganese (II) Sulfide	MnS	3.990	9.390
Manganese Oxide	MnO	5.390	18.908
Mercury	Hg	13.460	11.930
Molybdenum	Mo	10.200	34.360
Nickel	Ni	8.910	26.680
Niobium	Nb	8.570	17.910
Palladium	Pd	12.000	24.730
Platinum	Pt	21.400	36.040
Potassium	K	0.860	0.867
Potassium Bromide	KBr	2.750	4.665
Potassium Chloride	KCl	1.980	4.310
Potassium Iodide	KI	3.128	4.251

MATERIAL NAME	SYMBOL	DENSITY gm/cm ³	ACOUSTIC x10 ⁵ gm/cm ² sec
Rhenium	Re	21.040	58.870
Rhodium	Rh	12.410	42.050
Rubidium	Rb	1.530	3.476
Ruthenium	Ru	12.362	48.516
Samarium	Sm	7.540	9.920
Scandium	Sc	3.000	9.700
Selenium	Se	4.820	10.220
Silicon	Si	2.320	12.400
Silicon (II) Oxide	SiO	2.130	10.150
Silicon Dioxide (fused quartz)	SiO ₂	2.200	8.250
Silver	Ag	10.500	16.690
Silver Bromide	AgBr	6.470	7.480
Silver Chloride	AgCl	5.560	6.690
Sodium	Na	0.970	1.840
Sodium Chlorate	NaClO ₃	2.164	5.642
Sodium Chloride	NaCl	2.170	5.620
Sodium Fluoride	NaF	2.558	9.305
Sodium Nitrate	NaNO ₃	2.270	7.395
Strontium Fluoride	SrF ₂	4.277	12.146
Strontium Oxide	SrO	4.990	17.079
Sulphur	S	2.070	3.860
Tantalum	Ta	16.600	33.700
Tantalum (IV) Oxide	Ta ₂ O ₅	8.200	29.430
Tellurium	Te	6.250	9.810
Tellurium Oxide	TeO ₂	5.990	10.244
Terbium	Tb	8.270	13.380
Thallium	Tl	11.850	5.700
Thorium	Th	11.694	18.244
Thorium Dioxide	ThO ₂	9.860	31.092
Tin	Sn	7.300	12.200
Titanium	Ti	4.500	14.060
Titanium (IV) Oxide	TiO ₂	4.260	22.070
Tungsten	W	19.300	54.170
Tungsten Carbide	WC	15.600	58.480
Uranium	U	18.700	37.100
Uranium Dioxide	UO ₂	10.970	30.874
Uranium Oxide	U ₄ O ₉	10.969	25.374
Vanadium	V	5.960	16.660
Ytterbium	Yb	6.980	7.810
Yttrium	Y	4.340	10.570
Zinc	Zn	7.040	17.180
Zinc Oxide	ZnO	5.610	15.880
Zinc Selenide	ZnSe	5.260	12.230
Zinc Sulfide	ZnS	4.090	11.390
Zinc Telluride	ZnTe	6.340	11.468
Zirconium	Zr	6.510	14.720
Zirconium Carbide	ZrC	6.730	33.447



neyco

30 avenue de la Paix
92170 Vanves - France
Tel: +33(0)1 41 90 50 50
Fax: +33(0)1 41 90 50 51

www.neyco.fr



Materials N 2018-1

neyco



MATERIALS MANUFACTURING & QUALITY

-
- Manufacturing & Quality..... 0 03
 - Conversion Tables 0 07



Neyco's Headquarter in Vanves, south of Paris (FRANCE).



Our Plant in Lannion (FRANCE).

Manufacturing & Quality

Manufacturing and offering technical support in vacuum and inorganic materials require a strong scientific background and a strong organization.

To ensure the best answers to your needs as well as a consistency over years, Neyco uses the ISO 9001 Quality Management System.

ISO 9001 and ISO 14001 Management Systems enable Neyco to trace all new materials, to active all certificates of analysis, to ensure that all deliveries match with specific needs within the strict respect of our environment.



Induction furnace

MANUFACTURING

- Vacuum melted targets.
- Vacuum melted pellets.
- Vacuum melted alloys for targets, pellets, pieces and sprayed powders.
- Inert Gas Hot Pressing for targets and evaporation pieces (uncalibrated) with HIP quality to minimize gaseous inclusions.
- Mechanical machining of targets, backing plates with tolerances for flatness and overall dimensions.



Mechanical machining of backing plate



Powder conditioning



Vacuum furnace for metal powder production



Arc furnace



STOCK AND DELIVERY SERVICE

Extensive stock holdings, efficient computerised stock control and a well organised packing and dispatch department, contribute to the company's reputation for fast efficient service.



ANALYSIS

All our materials are delivered with a specific quantitative analysis. Analysis equipment depends on the total of impurities.

- GDMS (Glow Discharge Mass Spectroscopy) is to be chosen for purities > 99.999% (for MBE materials or very strict applications).
- MS (Mass Spectroscopy) is the general analysis for 99% to 99.99% (such as ICP).
- For non-metallic impurities (such as O₂, C...) we use LECO equipment.

The Certificate of Analysis provided with each lot assures that the final product meets or exceeds the exact specifications.



ISO 9001:2008 certificate



ISO 14001:2004 certificate

NEYCO is also equipped with a X-fluorescence analyzer (XRF analysis) enabling us to verify the alloys composition as well as to confirm integrity of the packed materials.

A green round sticker is then added on the external packaging once the FLUO-X is positively done.

TRACEABILITY

Each single order (without any minimum amount) has its own internal file number related to both a paper file and a SAP file. Manufacturing process and requested dimensions are noted on this file as well as specific requirements (density, particle size, impurities to avoid...). One can always refer to a previous order (within five years) and we shall then have all the necessary information to reproduce the manufacturing process or even improve when possible.

Each lot number is thus related to an analysis which is kept in our files for a minimum period of five years after manufacturing.

STANDARDS

Neyco started in 1988 the Assurance Quality process in order to settle firm bases of quality, for our own working way as well as for customer. We started with the ISO 9002 Certification, then obtained the ISO 9001 Certification in 2001 and we recently improved with the ISO 14001 Certification. All our certifications are given by AFNOR-AFAQ as a well-known certification organization. We maintained over the years the Quality meetings on a monthly basis, and all non-conformities, modifications, quality improvements, new ideas... are discussed during these meetings, meaning that everyone is correctly informed and trained for customer's satisfaction as well as personal development which should go together.

REACH COMPLIANCE

REACH (Registration, Evaluation and Authorisation of Chemicals), the most significant change in the European Union's (EU) chemical management history, started in June 2007. REACH is a EU regulation, which applies to all materials circulating in European Union becoming by the law global compliance matter.

REACH aims to **better protect human health and the environment** as well as enhance the competitiveness of the chemical industry by fostering innovation.

Neyco pre-registered substances in its current portfolio for which it has responsibilities and obligations to match REACH requirements.

The CLP Regulation (Regulation (EC) No 1272/2008) is the European Regulation on Classification, Labelling and Packaging of chemical substances and mixtures. The legislation introduces, throughout the EU, a new system for classifying and labelling chemicals, based on the United Nations' Globally Harmonised System (UN GHS). Correct and unambiguous substance identification is essential for Neyco:

- Each hazardous chemical product is delivered with a MSDS (Material Safety Data Sheet).
- Each container of hazardous chemical product is labelled as specified in the CLP Regulation.

ETHICAL CHART

We, at Neyco, consider that there is no business without human values and we are committed to :

- Enhance individual development and create good balance between personal life and work.
- Perform human management to avoid internal stress and hard feelings.
- Strictly prohibit false promises and twisted truths.
- Attribute a consequent yearly budget for national NGO (ie. "Abbé Pierre", "Restaurants du Coeur").
- Attribute a consequent yearly budget for international NGO (ie. "Salvation Army", "Red Cross").
- Develop an ecofriendly business by a continuous tracking of our various consumptions.
- Built a long term relationship with our partners as well as with our employees.



Conversion Tables

COMMON CONVERSION FACTORS

PARTS PER MILLION	PARTS PER BILLION	PERCENT
10 000 ppm	10 000 000 ppb	1%
1 000 ppm	1 000 000 ppb	0.1%
100 ppm	100 000 ppb	0.01%
10 ppm	10 000 ppb	0.001%
1 ppm	1 000 ppb	0.0001%
0.1 ppm	100 ppb	0.00001%
0.01 ppm	10 ppb	0.000001%

PRESSURE

	Pa (N.m ⁻²)	bar	mbar	µbar (dyn.cm ⁻²)	Torr (mm Hg)	atm	psi (lb.inch ⁻²)
1 Pa (N.m⁻²)	1	1.10 ⁻⁵	1.10 ⁻²	10	7.5.10 ⁻³	9.87.10 ⁻⁶	1.45.10 ⁻⁴
1 bar	1.10 ⁵	1	1000	1.10 ⁶	750	0.987	14.5
1 mbar	100	1.10 ⁻³	1	1000	0.75	9.87.10 ⁻⁴	1.45.10 ⁻²
1 µbar (dyn.cm⁻²)	0.1	1.10 ⁻⁶	1.10 ⁻³	1	7.5.10 ⁻⁴	9.87.10 ⁻⁷	1.45.10 ⁻⁵
1 Torr (mm Hg)	133.3	1.333.10 ⁻³	1.333	1333	1	1.32.10 ⁻³	1.93.10 ⁻²
1 atm	1.01.10 ⁵	1.013	1013	1.01.10 ⁶	760	1	14.7
1 psi (lb.inch⁻²)	6.89.10 ³	6.89.10 ⁻²	68.9	6.89.10 ⁴	51.71	6.8.10 ⁻²	1

GAS FLOW AND LEAK RATE

	Pa.m ³ .s ⁻¹	mbar.l.s ⁻¹	Torr.l.s ⁻¹	atm.cm ³ .s ⁻¹	lusec	sccm	slm	Mol.s ⁻¹
1 Pa.m³.s⁻¹	1	10	7.5	9.87	7.5.10 ³	592	0.592	4.41.10 ⁻⁴
1 mbar.l.s⁻¹	0.1	1	0.75	0.987	750	59.2	5.92.10 ⁻²	4.41.10 ⁻⁵
1 Torr.l.s⁻¹	0.1333	1.333	1	1.32	1000	78.9	7.89.10 ⁻²	5.85.10 ⁻⁵
1 atm.cm³.s⁻¹	0.101	1.01	0.76	1	760	60	6.10 ⁻²	4.45.10 ⁻⁵
1 lusec	1.333.10 ⁻⁴	1.333.10 ⁻³	10 ⁻³	1.32.10 ⁻³	1	7.89.10 ⁻²	7.89.10 ⁻⁵	5.86.10 ⁻⁸
1 sccm	1.69.10 ⁻³	1.69.10 ⁻²	1.27.10 ⁻²	1.67.10 ⁻²	12.7	1	10 ⁻³	7.45.10 ⁻⁷
1 slm	2.69	16.9	12.7	16.7	1.27.10 ⁴	1000	1	7.45.10 ⁻⁴
1 Mol.s⁻¹	2.27.10 ³	2.27.10 ⁴	1.7.10 ⁴	2.24.10 ⁴	1.7.10 ⁷	1.34.10 ⁶	1.34.10 ³	1

PUMPING SPEED

	m ³ .s ⁻¹	l.s ⁻¹	m ³ .h ⁻¹	l.min ⁻¹	cfm
m³.s⁻¹	1	10 ³	3600	6.10 ⁴	2.12.10 ³
l.s⁻¹	10 ⁻³	1	3.6	60	2.12
m³.h⁻¹	2.78.10 ⁻⁴	2.78.10 ⁻¹	1	16.7.10 ⁻⁵	5.89.10 ⁻¹
l.min⁻¹	1.67.10 ⁻⁵	1.67.10 ⁻²	6.10 ⁻²	1	3.536.10 ⁻²
cfm	4.72.10 ⁻⁴	0.47195	1.699	28.32	1

TEMPERATURE

	K	°C	°F
1 K	1	K - 273.15	5/9 x (K - 459.67)
1°C	°C + 273.15	1	5/9 x (°C + 32)
1°F	5/9 x (°F + 459.67)	5/9 x (°F - 32)	1

°C	-50	0	50	100	150	200	250
°F	-58	32	122	212	302	392	482

VARIOUS UNIT CONVERSIONS

To convert	Into	Multiply by
ampere-turn	gilbert	1.257
ampere-turn/cm	ampere.turn/in	2.54
ampere-turn/in	Gilbert/cm	0.495
ampere-turn/in	ampere.turn/cm	0.3937
ampere/cm ²	Ampere/in	6.452
angstrom	microinch	0.00393
angstrom	millimicron	0.1
angstrom	cm	10 ⁸
angstrom	nanometer	0.1
angstrom	micron	10 ⁴
b/mil ft	grams/cm ³	2.306.10 ⁶
Btu	joule	1055.1
Btu	kilowatt.hour	2.9290.10 ⁴
Btu	ft.lb	777.6
Btu/minute	watt	17.57
calorie (kg)	joule	4184
calorie (kg)	Btu	3.968
calorie (kg)	horsepower.hr	1.558.10 ³
calorie (kg)	ft.lb	3086
calories (kg)	kilowatt.hour	1.162.10 ³
circular mil	cm ²	5.067.10 ⁶
circular mil	in ²	7.854.10 ⁷
circular mil sq	mil	0.7854
cm	mil	393.7
cm	inch	0.3937
cm	angstrom	10 ⁸
cm ²	ft ²	1.076.10 ³
cm ²	circular mil	1.974.10 ⁵
cm ²	in ²	0.155
cm ³	gallon	2.642.10 ⁴
cm ³	in ³	6.102.10 ²
cm ³	quarts (liquid)	1.057.10 ³
cm ³	liter	10 ³
cm ³	ft ³	3.531.10 ⁵
cm ³	pints (liquid)	2.113.10 ³
coulombs/in ²	coulombs/cm ²	0.155
degree (angle)	minute	60
degree (angle)	second	3600
degree (angle)	radian	0.01745
degree/sec	radian/sec	0.01745
degree/sec	revolution/sec	0.002778
degree/sec	rpm	0.1667
dyne	pound	2.248.10 ⁶
dyne	gram	1.020.10 ³
dynes/cm ²	bar	10 ⁶

To convert	Into	Multiply by
erg	dyne.cm	1
erg	kg.meter	1.020.10 ⁸
erg	gram.cm	1.020.10 ³
erg	ft.lb	7.376.10 ⁸
erg	kg.calorie	2.390.10 ¹¹
erg	joule	10 ⁷
erg	Btu	9.486.10 ¹¹
ergs/sec	Btu/min	5.691.10 ⁹
ergs/sec	kilowatt	10 ¹⁰
ergs/sec	ft.lb/min	4.42.10 ⁶
eV	joule	1.602177.10 ¹⁹
feet	cm	30.48
feet	meter	0.3048
ft-lb	meter.kilogram	0.1383
ft-lb	cm.gram	13.826
ft-lb	cm.dyne	1.356.10 ⁷
ft ²	in ²	144
ft ²	m ²	0.0929
ft ²	cm ²	929
ft ³	lb.water	62.4
ft ³	liter	28.32
ft ³	pint (liquid)	59.84
ft ³	cm ³	2.832.10 ⁴
ft ³	in ³	1728
ft ³	m ³	0.02832
ft ³	quart (liquid)	29.92
ft ³	gallon	7.481
ft ³	yd ³	0.03704
ft ³ /min	gallon/sec	0.1247
ft ³ /min	cm ³ /sec	471.9
ft ³ /min	liter/sec	0.4719
gallon	quart (liquid)	4
gallon	liter	3.7854
gallon	cm ³	37854
gallon	pint (liquid)	8
gallon	ft ³	0.1337
gallon	lb.water	8.34
gallon	in ³	231
gallon	m ³	3.785.10 ³
gallon/min	liter/sec	0.064
gallon/min	ft ³ /sec	2.228.10 ³
gauss	lines/in ²	6.452
gilbert	ampere.turn	0.7958
gram	oz	0.03527
gram	dyne	980.7

To convert	Into	Multiply by
gram	lb	2.205.10 ⁻³
gram-calorie	Btu	3.968.10 ⁻³
gram-cm	kg.meter	10 ⁻⁵
gram-cm	joule	9.807.10 ⁻⁵
gram-cm	ft.lb	7.233.10 ⁻⁵
gram-cm	erg	980.7
gram-cm	Btu	9.302.10 ⁻⁸
gram-cm	kg.calorie	2.344.10 ⁻⁸
gram/cm	lb/in	5.6.10 ⁻³
gram/cm ³	lb/circular mil ft	3.405.10 ⁻⁷
gram/cm ³	lb/in ³	0.03613
gram/cm ³	lb/ft ³	62.43
horsepower	j/s	745.70
horsepower	horsepower (EU metric)	1.014
horsepower (UK)	watt	745.7
in ²	ft ²	6.944.10 ⁻³
in ²	cm ²	6.4516
in ²	mm ²	645.2
in ³	pint (liquid)	0.0346322
in ³	quart (liquid)	0.01732
in ³	liter	1.639.10 ⁻²
in ³	gallon	4.329.10 ⁻³
in ³	m ³	1.639.10 ⁻⁵
in ³	ft ³	5.787.10 ⁻⁴
in ³	cm ³	16.39
inch	angstrom	2.54.108
inch	cm	2.54
joule	watt.hour	2.778.10 ⁻⁴
joule	calorie	2389.10 ⁻⁴
joule	ft.lb	0.7377
joule	erg	10 ⁷
joule	Btu	9.486.10 ⁻⁴
kilogram	tons (short)	1.102.10 ⁻³
kilogram	lb	2.2046
kilogram (force)	dyne	980665
kilogram-meter	kilowatt.hour	2.724.10 ⁻⁶
kiloline	maxwell	10 ³
kilometer	mile	0.6214
kilometer	feet	3281
kilowatt	ft.lb/sec	737.6
kilowatt	ft.lb/min	4.425.10 ⁴
kilowatt	Btu/minute	56.92
kilowatt-hour	kilogram.meter	3.671.10 ⁵
kilowatt-hour	joule	3.6.10 ⁶
kilowatt-hour	ft.lb	2.655.10 ⁶
kilowatt-hour	Btu	3415
km/hour	m/min	16.67

To convert	Into	Multiply by
km/hour	mile/hour	0.6214
km/hour	ft/sec	0.9113
km/hour	ft/min	54.68
km/hour	cm/sec	27.78
km ²	ft ²	1.076.10 ⁷
lb water	gallon	0.1198
lb water	in ³	27.68
lb water	ft ³	0.01602
lb water/min	ft ³ /sec	2.669.10 ⁻⁴
lb/ft	kg/meter	1.488
lb/ft ²	kg/m ²	4.882
lb/ft ²	ft. water	0.01602
lb/ft ²	lb/in ²	6.944.10 ⁻³
lb/in	grams/cm	178.6
lb/in ²	lb/ft ²	144
lb/in ²	kg/m ²	703.1
lb/in ²	in.Hg	2.036
lb/in ²	ft.water	2.307
lb/in ²	atmosphere	0.06804
lines/cm ²	gauss	1
lines/in ²	gauss	0.155
liter	quart (liquid)	1.057
liter	pint (liquid)	2.113
liter	gallon	0.2642
liter	in ³	61.02
liter	ft ³	0.03531
liter/min	gallon/sec	4.403.10 ⁻³
liter/min	ft ³ /sec	5.885.10 ⁻⁴
lumen/ft ²	foot.candle	1
m/min	miles/hour	0.03728
m/min	km/hour	0.06
m/min	ft/sec	0.05468
m/sec	miles/min	0.03728
m/sec	km/min	0.06
m/sec	km/hr	3.6
m/sec	ft/sec	3.281
m/sec	ft/min	196.8
m/sec	miles/hour	2.237
m ²	sq mile	3.861.10 ⁻⁷
m ²	ft ²	10.764
m ³	quarts (liquid)	1057
m ³	pints (liquid)	2113
m ³	gallon	264.2
m ³	in ³	61024
m ³	ft ³	35.31
m ³	cm ³	10 ⁶
maxwell	kiloline	36802

To convert	Into	Multiply by
megaline	maxwell	10 ⁶
meter	inch	39.37
meter	feet	3.2808
meter	angstrom	10 ¹⁰
mhos/mil ft	megmhos/in ³	15.28
mhos/mil ft	megmhos/cm ³	6.015
microhm/cm ³ ohms/mil	ft	6.015
microhm/cm ³	microhms/in ³	0.3937
microhm/in ³	microhm/cm ³	2.54
microinch	angstrom	254
micromicron	angstrom	0.01
micron	angstrom	10000
mil	inch	36802
mil	cm	0.0025
milliliter	cm ³	1
millimeter	mil	39.37
millimeter	micron	1000
millimeter	inch	0.03937
millimeter	angstrom	107
millimicron	angstrom	10
minute	seconds (angle)	60
minutes (angle)	radian	2.909.10 ⁻⁴
mm ²	in ²	1.55.10 ⁻³
mm ²	cm ²	0.01
mm ² circular	mil	1.974.103
nanometer	micron	10-3
ohms/mil ft	microhm/in ³	0.06524
ohms/mil ft	microhm/cm ³	0.1662
ounces (fluid)	liter	0.02957
ounces (fluid)	in ³	1.805
oz/in ²	psi	0.0625
pints (liquid)	in ³	28.88
pints (dry)	in ³	33.6
pound	oz	16
pound	gram	453.6
pound (force)	dyne	444823
quadrants (angle)	radian	1.571
quadrants (angle)	minute	5400
quadrants (angle)	degree	90
quart fluid	ounce	32
quarts (liquid)	in ³	57.75
quarts (dry)	in ³	67.2
radian	degrees/sec	57.3
radian	quadrant	0.637
radian	minute	3438
radian	degree	57.3

To convert	Into	Multiply by
radians/sec	revolutions/sec	0.1592
radians/sec	rpm	9.549
revolution	radian	6.283
revolution	quadrant	4
revolution	degree	360
revolutions/sec	rpm	60
revolutions/sec	radians/sec	6.283
revolutions/sec	degrees/sec	360
rpm	revolutions/sec	0.01667
rpm	radians/sec	0.1047
rpm	degrees/sec	6
seconds (angle)	radian	4.848.10 ⁻⁶
spheres (solid angle)	steradian	12.57
spherical rt. angle	steradian	1.571
spherical rt. angle	sphere	0.125
spherical rt. angle	hemisphere	0.25
steradian	sphere	0.07958
steradian	hemisphere	0.1592
stere	liter	10 ³
tons (short)	lb	2000
tons (short)	kg	907.2
tons (metric)	lb	2205
tons (metric)	kg	10 ³
tons (long)	lb	2240
tons (long)	kg	1016
watt	kilowatt	36802
watt	ft.lb/sec	0.7376
watt	ft.lb/min	44.25
watt	ergs/sec	10 ⁷
watt	Btu/min	0.05692
watt-hour	kilogram.meter	367.1
watt-hour	ft.lb	2655
watt-hour	Btu	3.414
weber	maxwell	10 ⁸



neyco

30 avenue de la Paix
92170 Vanves - France
Tel: +33(0)1 41 90 50 50
Fax: +33(0)1 41 90 50 51

www.neyco.fr



Materials O 2018-1

neyco